

tm1513 - 410D, 510D Backhoe Loaders Repair Remove And Disassemble Oil Pump And Manifold

Remove And Disassemble Oil Pump And Manifold

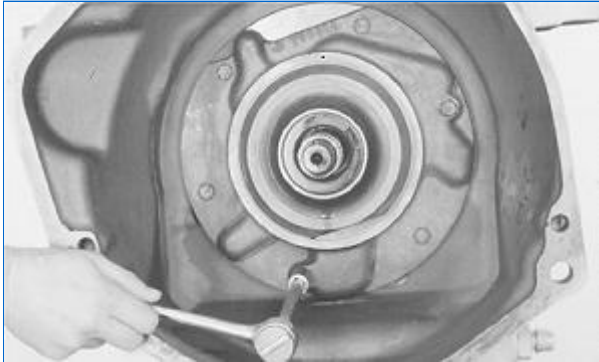

1. T91885-UN: Turbine Shaft Removal

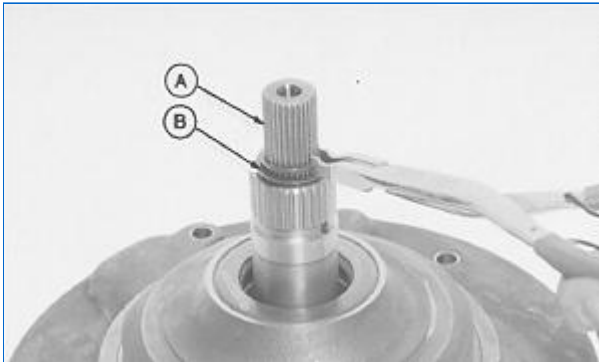

- T91886-UN: Washer And Turbine Shaft

Remove snap ring, washer (B) and turbine shaft (A). Be sure not to damage manifold bushing when removing shaft.



2. T91887-UN: Remove Manifold

Remove manifold.



3. T91888-UN: Blind Hole Puller

Remove bushing with blind hole puller.

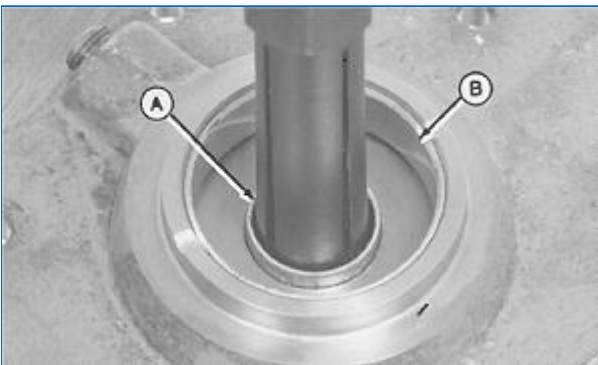

4. T91889-UN: Remove Bushing

Remove bushing (A) with blind hole puller.

5. Inspect bushing (B) for wear or damage. Remove if necessary.



6. T91890-UN: Remove Oil Pump

Remove oil pump from housing.

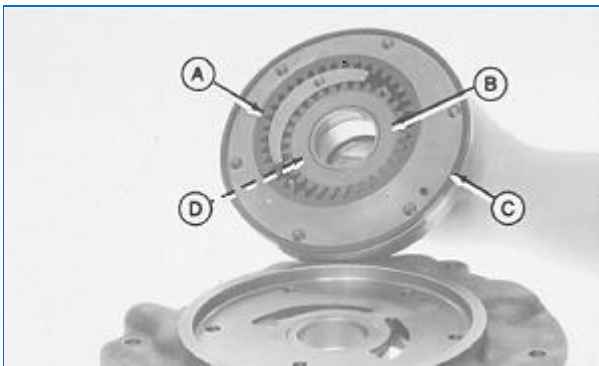

7. T91891-UN: Remove Parts

LEGEND:

- A - Internal Gear
- B - Drive Gear
- C - Packing
- D - Bushing

Remove internal gear (A), pump drive gear (B), and packing (C).

8. Inspect pump drive gear bushing (D).
-



9. T91892-UN: Seal And Bushing

Remove seal (A) with a slide hammer.

10. Inspect bushing (B). Remove if replacement is necessary.

TX,0350,DS3778-19-08AUG91

tm1513 - 410D, 510D Backhoe Loaders Repair

Remove And Disassemble Planetary Assembly

Remove And Disassemble Planetary Assembly

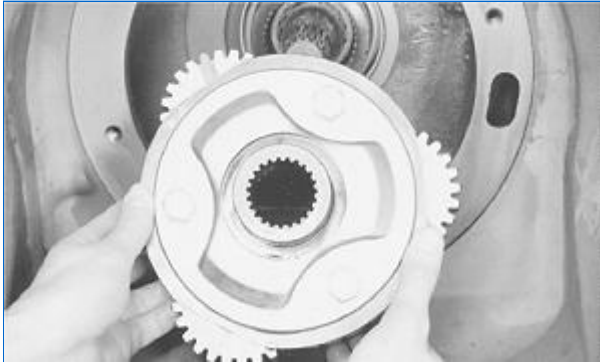

1. T91893-UN: Planetary

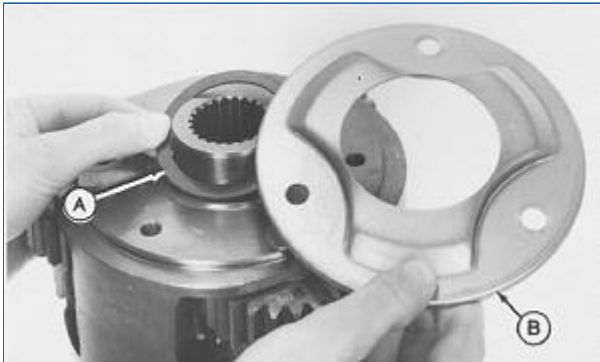

T91894-UN: Oil Baffle And Thrust Washer

Remove oil baffle (B) and thrust washer (A).

2. Remove thrust washer.



3. T91895-UN: First And Second Sun Gear

Remove second sun gear (A). Inspect bonded thrust washers on gear. If thrust washers are damaged, replace gear.

4. Remove first sun gear (B).

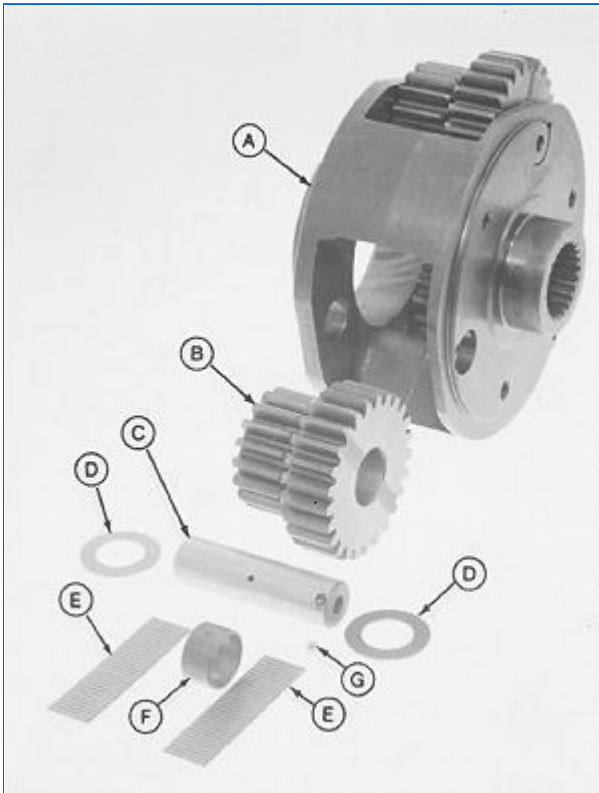

5. T91896-UN: Planetary Parts

LEGEND:

- A - Carrier
- B - Pinion (3 used)
- C - Shaft (3 used)
- D - Thrust Washer (6 used)
- E - Needle Bearings (186 used)
- F - Spacer (3 used)
- G - Ball (3 used)

Remove parts (A-G).

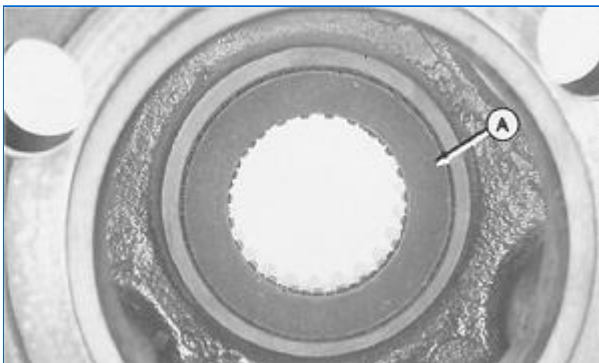

6. T91897-UN: Bonded Thrust Washer

Inspect bonded thrust washer (A). If thrust washer is damaged, replace carrier.

7. Thoroughly clean and inspect parts, replace as necessary.

tm1513 - 410D, 510D Backhoe Loaders Repair

Remove Rear Cover

Remove Rear Cover



1. T91898-UN: Cap Screws, Plate, O-Ring And Yoke

LEGEND:

- A - Cap Screw (2 used)
- B - Plate
- C - O-Ring
- D - Yoke

Remove parts (A-D).

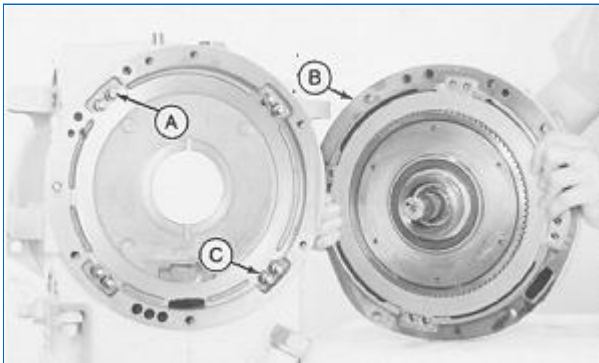

2. T91899-UN: Pin, Cover Assembly And Spring

LEGEND:

- A - Pin (8 used)
- B - Cover Assembly
- C - Spring (8 used)

Remove parts (A-C).

3. Check springs (C) for wear or damage. Check the compression rate of spring with compression tester.

Item	Measurement	Specification
New Spring	Free Length (approximate)	22 mm (0.87 in.)

tm1513 - 410D, 510D Backhoe Loaders Repair Remove Reverse Brake And Forward Clutch

Remove Reverse Brake And Forward Clutch

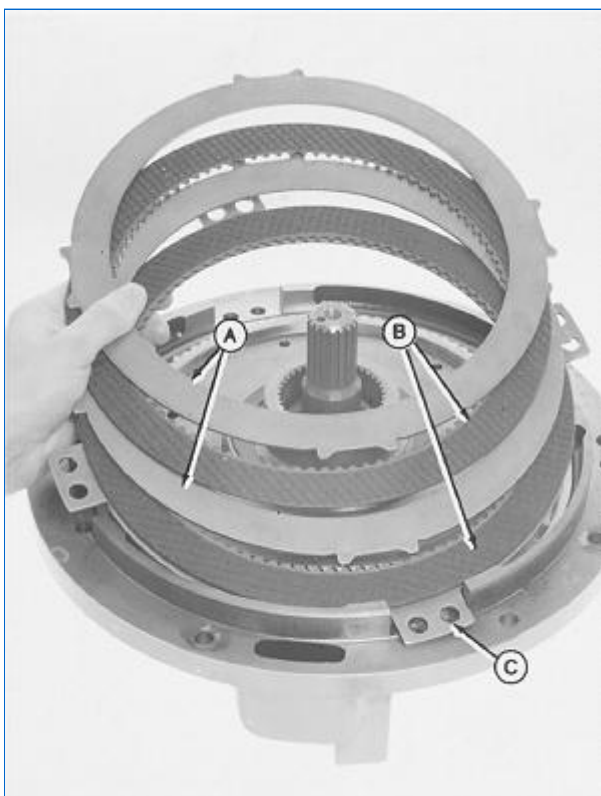

1.

T91900-UN: Remove Parts

Remove parts (A-C).

2. Inspect disk oil grooves for wear. When oil groove is badly worn, replace disk. Inspect disk inside teeth for damage; replace if necessary
-

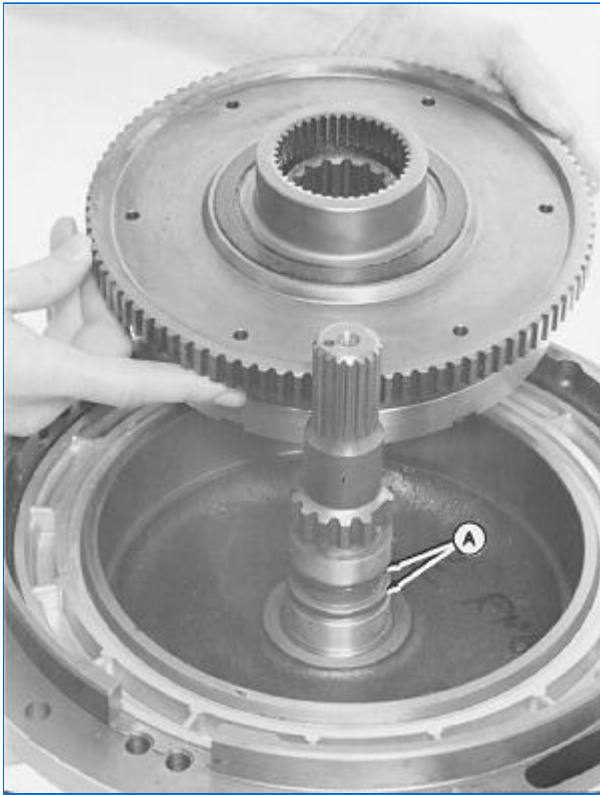

3. T91901-UN: Sealing Rings

Remove forward clutch. Care must be taken not to damage sealing rings (A).



4.

T91902-UN: Remove Piston And Packings

Remove piston and packings (A and B).

TX,0350,DS3789-19-28JAN94

tm1513 - 410D, 510D Backhoe Loaders Repair

Remove Output Shaft

Remove Output Shaft



1. T91909-UN: Remove Oil Seal

Remove oil seal using a slide hammer and attachments.

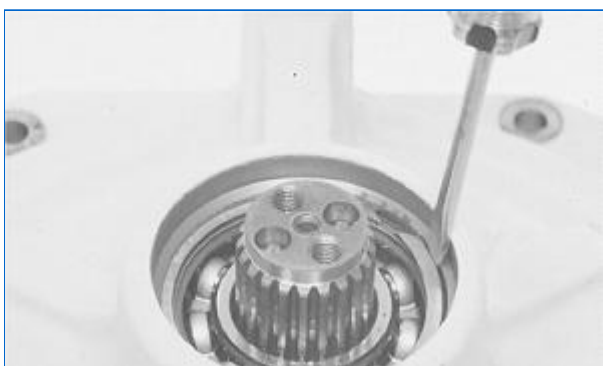

2. T91910-UN: Remove Snap Ring

Remove snap ring.



3. T91911-UN: Remove Shaft

Remove shaft with ball bearing by tapping on end of shaft while turning shaft. Care must be taken not to damage sealing rings.



4. T91912-UN: Remove Sealing Rings

Remove five sealing rings. Inspect sealing rings and shaft grooves for wear or damage; replace if necessary.

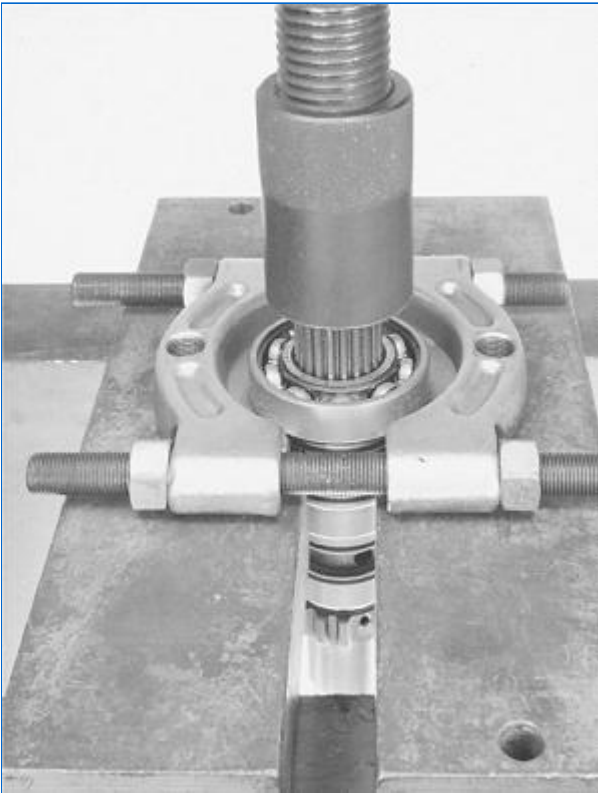

5. T91913-UN: Remove Ball Bearing

Remove ball bearing with a press and bearing puller. Replace if necessary.

tm1513 - 410D, 510D Backhoe Loaders Repair Disassemble Forward Clutch

Disassemble Forward Clutch

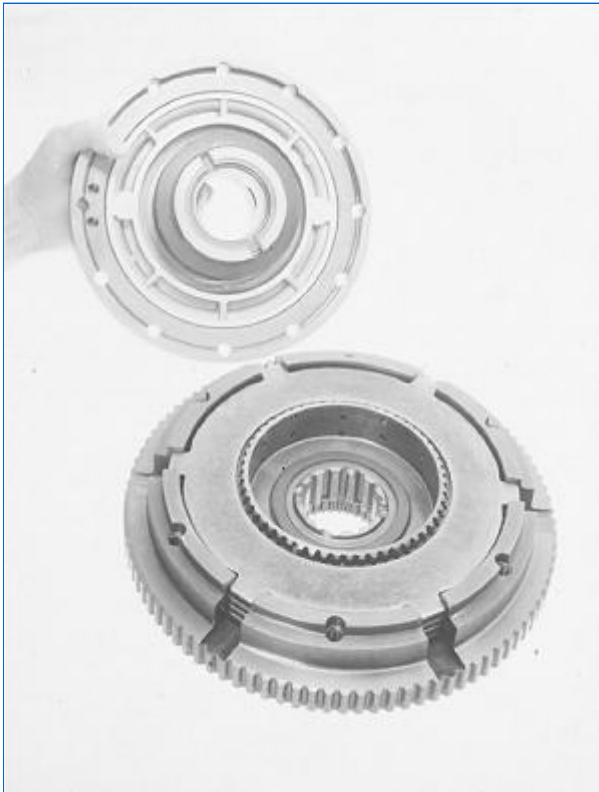

1. T91903-UN: Remove Piston Housing Assembly

Remove piston housing assembly.

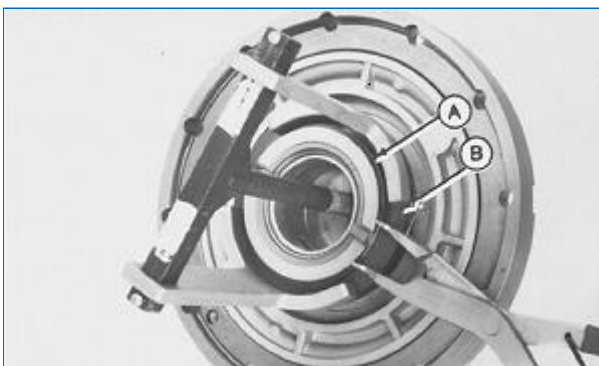

2. T91904-UN: Conical Washers, Snap Ring

Push conical (Belleville) washers (B) away from snap ring (A) using JDT24A Spring Washer Compressor. Remove snap ring and washers.



3. T91905-UN: Piston, Pin, Packing And Dump Valve

LEGEND:

- A - Piston
- B - Pin
- C - Packing (2 used)
- D - Dump Valve

Remove piston and packings (A and C).

4. Inspect dump valve (D) and pin (B). Remove if replacement is necessary.
-



5. T91906-UN: Inspect Bushings

Inspect bushings (A) for wear or damage. Replace if necessary.

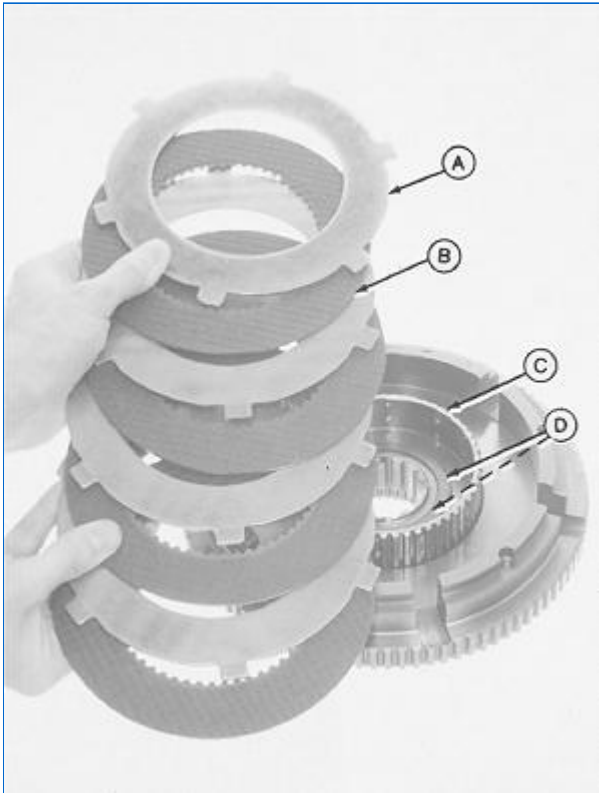

6. T91907-UN: Plates, Disk, Hub And Thrust Washer

LEGEND:

- A - Plate (4 used)
- B - Disk (4 used)
- C - Hub
- D - Thrust Washer (2 used)

Remove four plates (A) and disks (B).

7. Inspect disk oil grooves for wear. When oil groove is badly worn, replace disk. Inspect inside teeth for damage; replace if necessary.
8. Remove hub (C). Inspect bonded thrust washers (D) on both sides of hub.

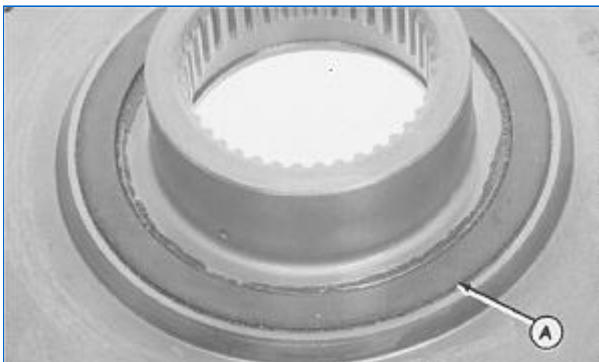

9. T91908-UN: Bonded Thrust Washer

Inspect bonded thrust washer (A) for wear or damage.

tm1513 - 410D, 510D Backhoe Loaders Repair Disassemble And Assemble Reverser Housing

Disassemble And Assemble Reverser Housing



1. T91914-UN: Remove Bushing

Remove bushing using 95 and 97 mm disks.

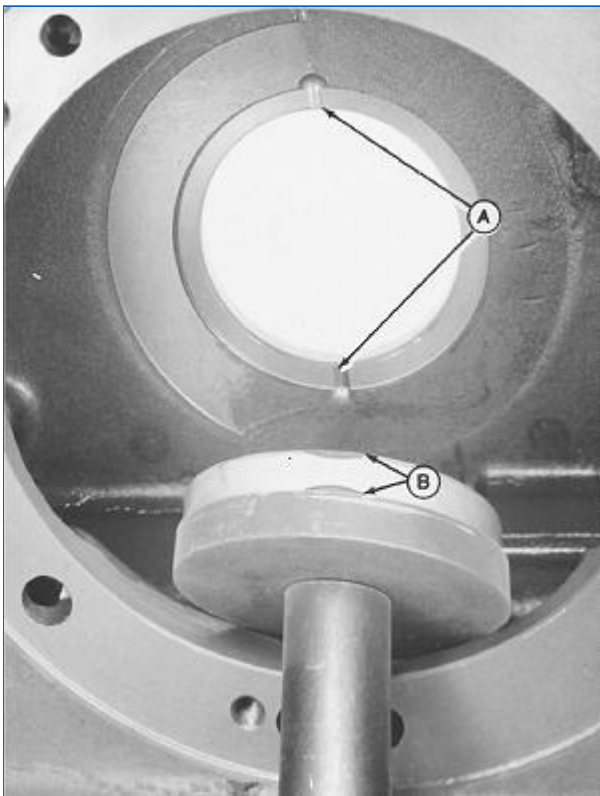

2. T91917-UN: Bushing Notches And Housing Grooves

Install bushing using 95 and 102 mm disks. Install bushing even with front edge of bore. Bushing notches (B) must be on same center line as housing grooves (A).

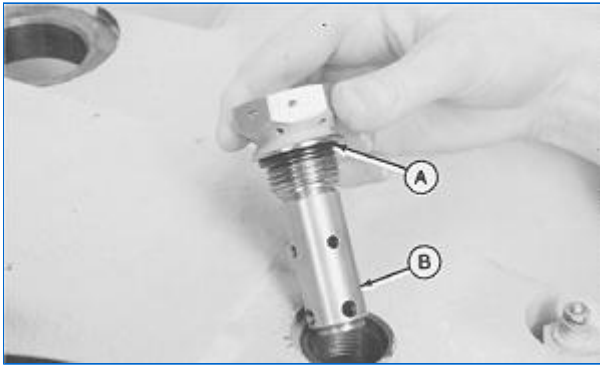

3. T91915-UN: Breather And O-Ring

For (410D-SN -796854)(510D-SN -796890) machines, remove breather (B) with O-ring (A). Clean breather using solvent and compressed air. Install breather with new O-ring.

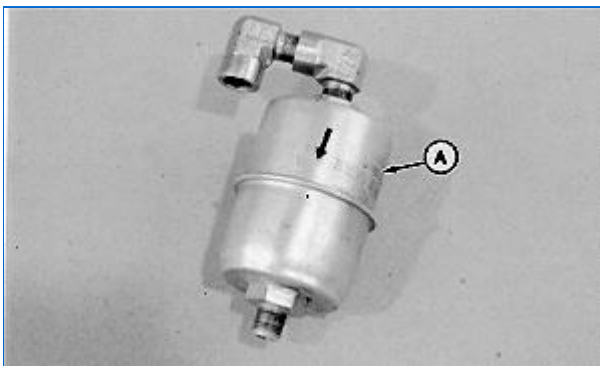

T8130BB-UN: Filter Canister

For (410D-SN 796855-)(510D-SN 796891-) machines, a filter canister (A) with elbows is used. Filter can not be cleaned, it must be replaced. Install filter with arrow pointing to reverser. Apply pipe sealant to filter and elbow threads.

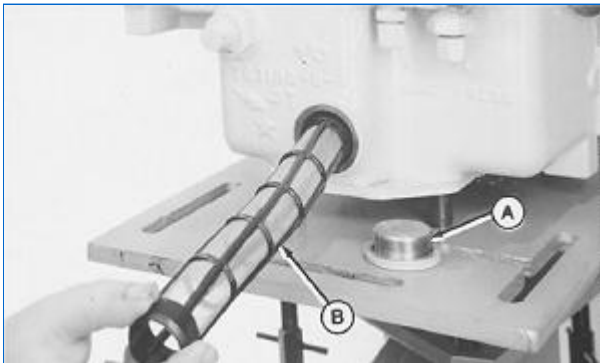

4. T91916-UN: Remove Plug And Suction Screen

Remove plug (A) and O-ring to remove suction screen (B).

Clean and install suction screen. Install plug and new O-ring. Screen may twist slightly when plug is tightened.

tm1513 - 410D, 510D Backhoe Loaders Repair Assemble Forward Clutch

Assemble Forward Clutch

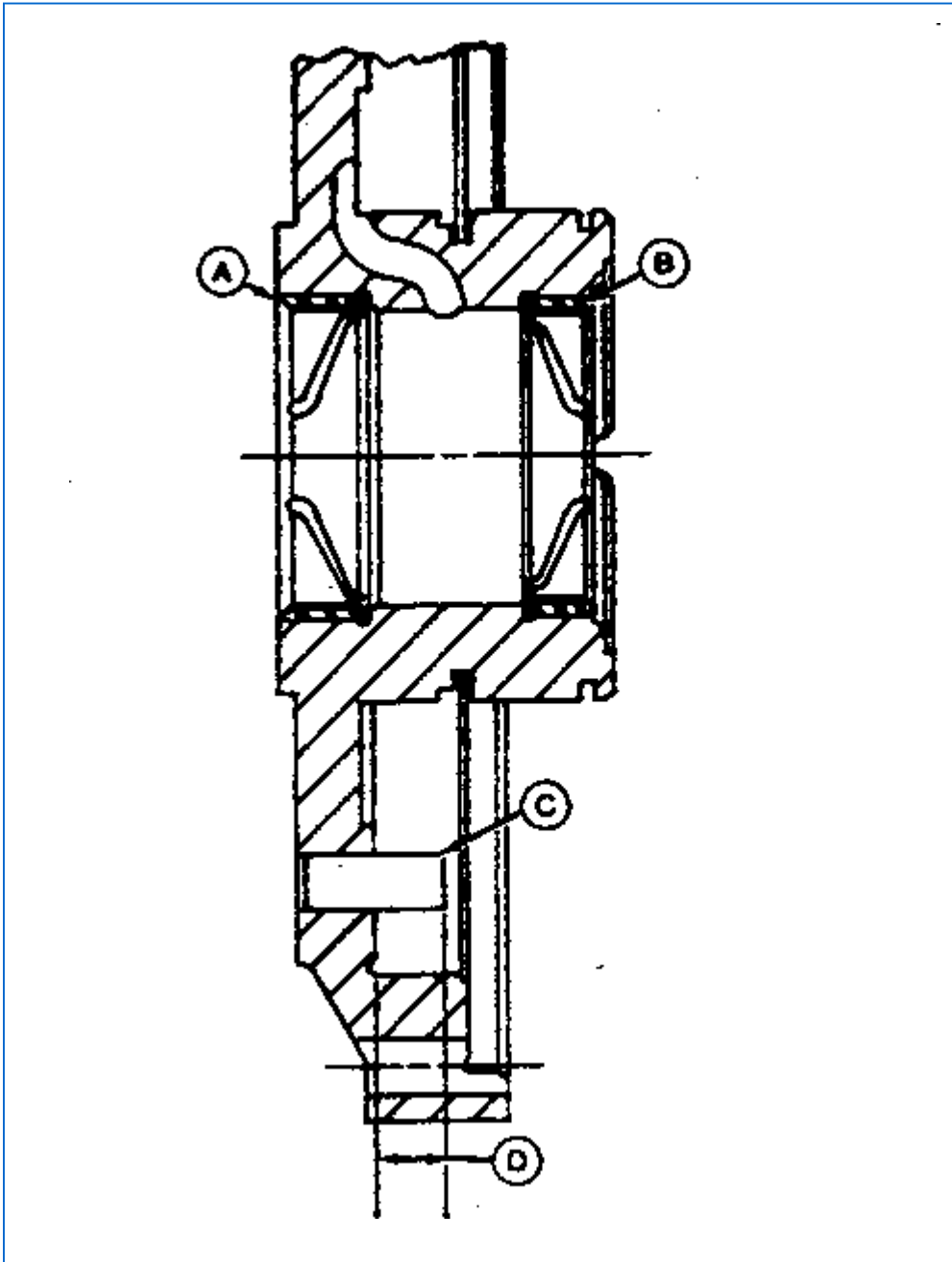

1. T91921-UN: Install Bushings And Pin

LEGEND:

- A - Bushing
- B - Bushing
- C - Pin
- D - 11.68 ± 0.25 mm (0.46 ± 0.01 in.)

Install bushings (A and B) with long chamfer side facing out. Use 55 and 47 mm disks.

2. Install pin (C), if removed, until 11.68 ± 0.25 mm (0.46 ± 0.01 in.) shows above face of housing.

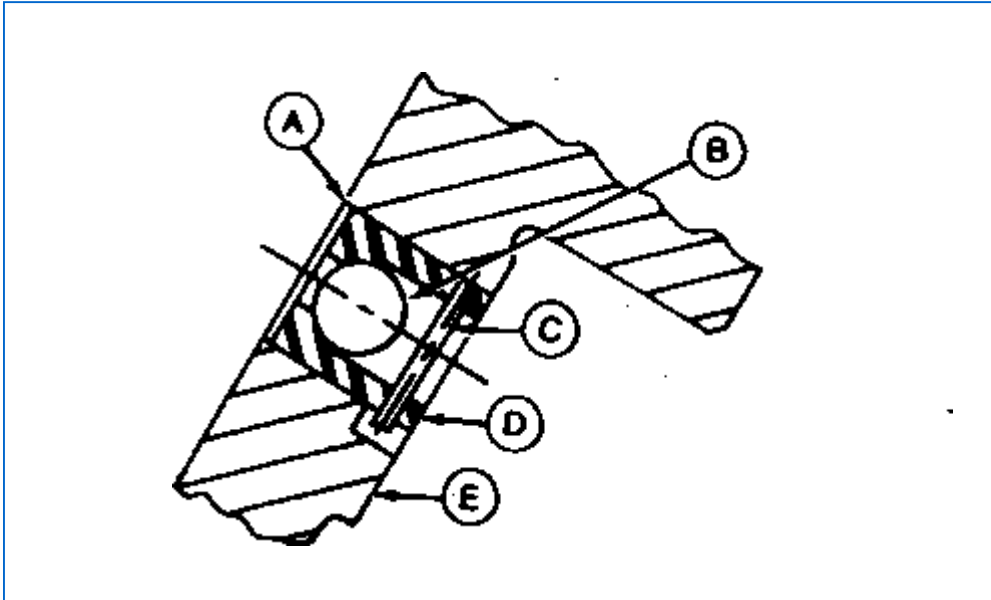

3. T91922-UN: Distance Below Housing



T91923-UN: Check Valve Seat, Ball And Housing

LEGEND:

- A - Check Valve Seat
- B - Ball
- C - Pin
- D - 0.25 mm (0.01 in.)
- E - Housing

Install parts (A-C). Press seat until it is even to 0.25 mm (0.01 in.) below surface of housing (E).



4. T91924-UN: Packings, Counter Bore And Pin

Install new packings (B) with thicker section of packings installed in grooves. Put petroleum jelly or oil soluble grease on packings.

5. Install piston with smooth face to bottom of bore. Be sure counter bore (A) in piston aligns with pin (C) in piston housing and that packings are not "rolled" or damaged when installing piston.

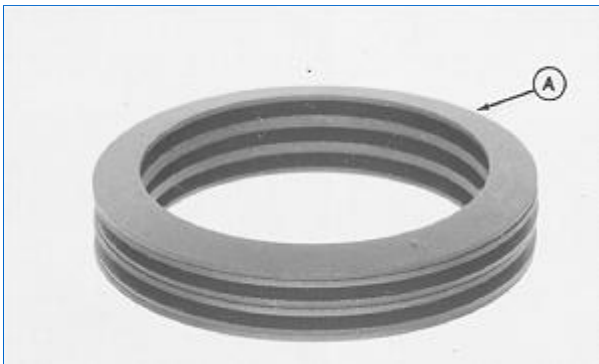

6. T91925-UN: Conical Washers

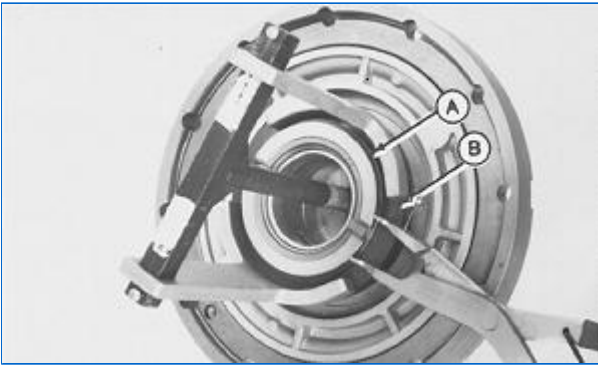

T91904-UN: Conical Washers And Snap Ring

Install conical washers (A). Be sure washers are aligned correctly.

7. Install spring compressor to compress washers and install snap ring (B).
-

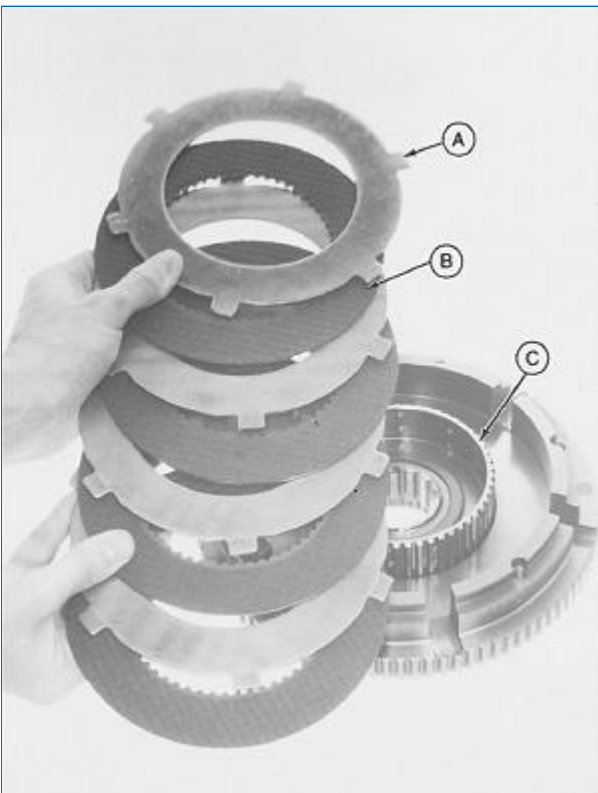

8. T91926-UN: Hub, Plates And Disks

Install hub (C).

9. Install four plates (A) and disks (B).
-

Thank you very much for your reading. Please Click Here. Then Get COMPLETE MANUAL. NO WAITING



NOTE:

If there is no response to click on the link above, please download the PDF document first and then click on it.



10.

T91873-UN: Tighten Cap Screws

Install new cap screws in piston housing assembly and tighten to 27 N·m (20 lb-ft).

Item	Measurement	Specification
Forward Clutch Cover Cap Screws	Torque	27 N·m (20 lb-ft)

tm1513 - 410D, 510D Backhoe Loaders Repair Install Output Shaft

Install Output Shaft



1. T91918-UN: Install New Ball Bearing

Install new ball bearing. Use a press and a piece of mechanical tubing 1.375 in. ID x 1.75 in. OD x 1.375 in. long.



2. T91912-UN: Install Five Sealing Rings

Install five sealing rings. Be sure they turn freely and do not bind in shaft grooves. Put petroleum jelly or an oil soluble grease on sealing rings.



3. T91919-UN: Lock Joints And Oil Bores

Align the three larger sealing ring lock joints (A) on shaft. Install shaft so locking joints do not align with oil bores (B) in cover. Install shaft until ball bearing is tight against shoulder in cover.



4. T91910-UN: Install Snap Ring

Install snap ring.
