

4500, 4600 and 4700 Compact Utility Tractors

TECHNICAL MANUAL

**John Deere
Commercial and Consumer
Equipment Division**

**TM1679 (Jun00)
Replaces TM1679 (Oct99)**



M94384

COMPACT UTILITY TRACTOR

This technical manual is written for an experienced technician and contains sections that are specifically for this product. It is a part of a total product support program.

The manual is organized so that all the information on a particular system is kept together. The order of grouping is as follows:

- Table of Contents
- Specifications
- Component Location
- System Schematic
- Theory of Operation
- Troubleshooting Chart
- Diagnostics
- Tests & Adjustments
- Repair











Note: Depending on the particular section or system being covered, not all of the above groups may be used.

Each section will be identified with a symbol rather than a number. The groups and pages within a section will be consecutively numbered.

We appreciate your input on this manual. To help, there are postage paid post cards included at the back. If you find any errors or want to comment on the layout of the manual please fill out one of the cards and mail it back to us.

All information, illustrations and specifications in this manual are based on the latest information available at the time of publication. The right is reserved to make changes at any time without notice.

COPYRIGHT© 2000
 Deere & Co.
 John Deere Worldwide Commercial and
 Consumer Equipment Division
 Horicon, WI
 All rights reserved
 Previous Revisions 1998

Safety	
Specifications and Information	
Diesel Engine	
Electrical	
Gear Power Train	
Hydrostatic Power Train	
PowrReverser™ Power Train	
Final Drive Power Train	
Steering	
Brakes	
Hydraulics	
Miscellaneous	M



RECOGNIZE SAFETY INFORMATION



This is the safety-alert symbol. When you see this symbol on your machine or in this manual, be alert to the potential for personal injury.

Follow recommended precautions and safe servicing practices.

Understand Signal Words

A signal word—DANGER, WARNING, or CAUTION—is used with the safety-alert symbol. DANGER identifies the most serious hazards.

DANGER or WARNING safety signs are located near specific hazards. General precautions are listed on CAUTION safety signs. CAUTION also calls attention to safety messages in this manual.

REPLACE SAFETY SIGNS

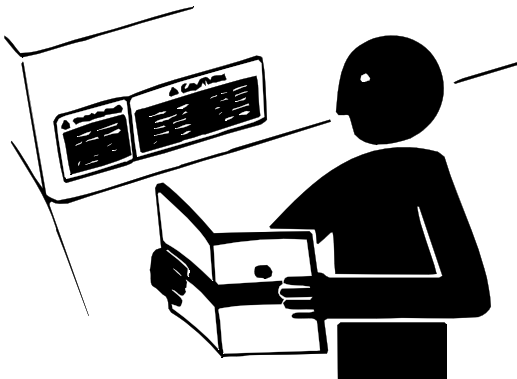

Replace missing or damaged safety signs. See the machine operator's manual for correct safety sign placement.

HANDLE FLUIDS SAFELY-AVOID FIRES

Be Prepared For Emergencies

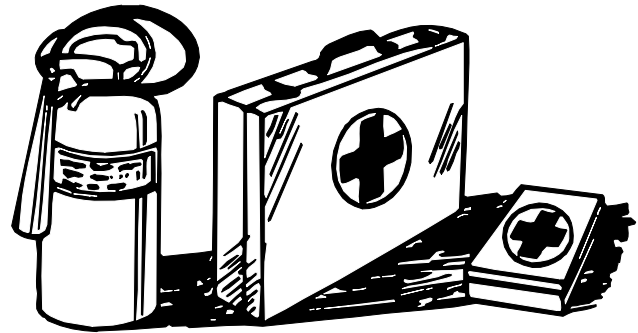

When you work around fuel, do not smoke or work near heaters or other fire hazards.

Store flammable fluids away from fire hazards. Do not incinerate or puncture pressurized containers.

Make sure machine is clean of trash, grease, and debris.

Do not store oily rags; they can ignite and burn spontaneously.

Be prepared if a fire starts.

Keep a first aid kit and fire extinguisher handy.

Keep emergency numbers for doctors, ambulance service, hospital, and fire department near your telephone.

USE CARE IN HANDLING AND SERVICING BATTERIES

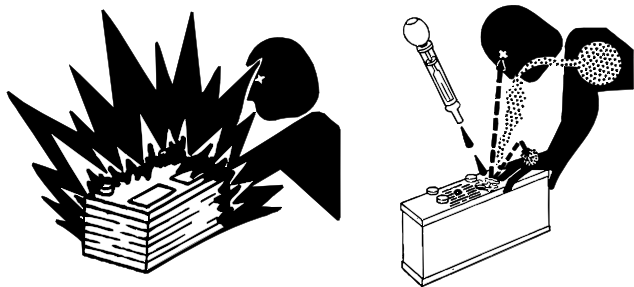

Prevent Battery Explosions

- Keep sparks, lighted matches, and open flame away from the top of battery. Battery gas can explode.
- Never check battery charge by placing a metal object across the posts. Use a volt-meter or hydrometer.
- Do not charge a frozen battery; it may explode. Warm battery to 16°C (60°F).

Prevent Acid Burns

- Sulfuric acid in battery electrolyte is poisonous. It is strong enough to burn skin, eat holes in clothing, and cause blindness if splashed into eyes.
- **Avoid acid burns by:**
 1. Filling batteries in a well-ventilated area.
 2. Wearing eye protection and rubber gloves.
 3. Avoiding breathing fumes when electrolyte is added.
 4. Avoiding spilling or dripping electrolyte.
 5. Use proper jump start procedure.
- **If you spill acid on yourself:**
 1. Flush your skin with water.
 2. Apply baking soda or lime to help neutralize the acid.
 3. Flush your eyes with water for 10_15 minutes.
 4. Get medical attention immediately.
- **If acid is swallowed:**
 1. Drink large amounts of water or milk.
 2. Then drink milk of magnesia, beaten eggs, or vegetable oil.
 3. Get medical attention immediately.

USE CARE AROUND HIGH-PRESSURE FLUID LINES

Avoid High-pressure Fluids

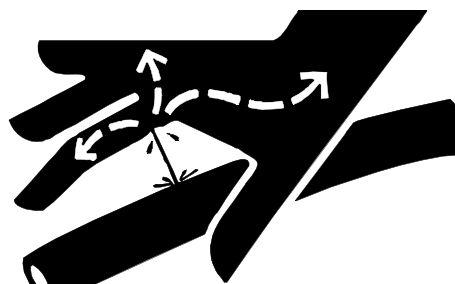

Escaping fluid under pressure can penetrate the skin causing serious injury.

Avoid injury from escaping fluid under pressure by stopping the engine and relieving pressure in the system before disconnecting or connecting hydraulic or other lines. Tighten all connections before applying pressure.

Search for leaks with a piece of cardboard. Protect hands and body from high pressure fluids.

If an accident occurs, see a doctor immediately. Any fluid injected into the skin must be surgically removed within a few hours or gangrene may result. Doctors unfamiliar with this type of injury should reference a knowledgeable medical source. Such information is available from Deere & Company Medical Department in Moline, Illinois, U.S.A.

Avoid Heating Near Pressurized Fluid Lines



Flammable spray can be generated by heating near pressurized fluid lines, resulting in severe burns to yourself and bystanders. Do not heat by welding, soldering, or using a torch near pressurized fluid lines or other flammable materials. Pressurized lines can be accidentally cut when heat goes beyond the immediate flame area.



USE SAFE SERVICE PROCEDURES

Wear Protective Clothing

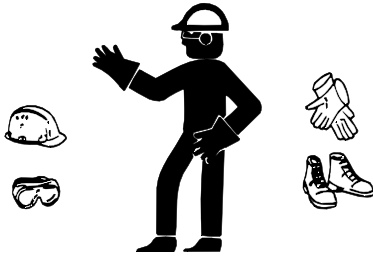

Wear close fitting clothing and safety equipment appropriate to the job.

Prolonged exposure to loud noise can cause impairment or loss of hearing. Wear a suitable hearing protective device such as earmuffs or earplugs to protect against objectionable or uncomfortable loud noises.

Operating equipment safely requires the full attention of the operator. Do not wear radio or music headphones while operating machine.

Service Machines Safely

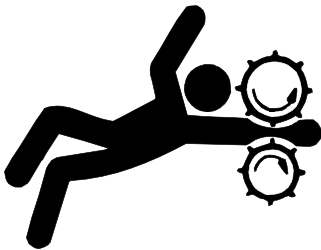

Tie long hair behind your head. Do not wear a necktie, scarf, loose clothing, or necklace when you work near machine tools or moving parts. If these items were to get caught, severe injury could result.

Remove rings and other jewelry to prevent electrical shorts and entanglement in moving parts.

Use Proper Tools

Use tools appropriate to the work. Makeshift tools and procedures can create safety hazards. Use power tools only to loosen threaded parts and fasteners. For loosening and tightening hardware, use the correct size tools. **DO NOT** use U.S. measurement tools on metric fasteners. Avoid bodily injury caused by slipping wrenches. Use only service parts meeting John Deere specifications.

Park Machine Safely

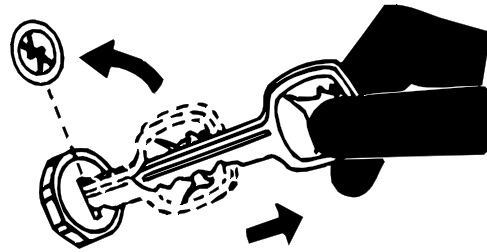

Before working on the machine:

1. Lower all equipment to the ground.
2. Stop the engine and remove the key.
3. Disconnect the battery ground strap.
4. Hang a "DO NOT OPERATE" tag in operator station.

Support Machine Properly And Use Proper Lifting Equipment

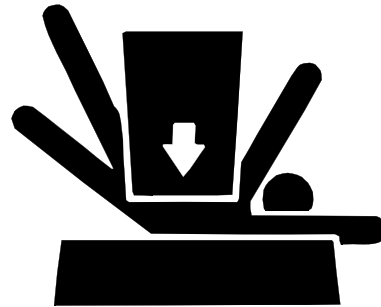

If you must work on a lifted machine or attachment, securely support the machine or attachment.

Do not support the machine on cinder blocks, hollow tiles, or props that may crumble under continuous load. Do not work under a machine that is supported solely by a jack. Follow recommended procedures in this manual.

Lifting heavy components incorrectly can cause severe injury or machine damage. Follow recommended procedure for removal and installation of components in the manual.

Work In Clean Area

Before starting a job:

1. Clean work area and machine.
2. Make sure you have all necessary tools to do your job.
3. Have the right parts on hand.
4. Read all instructions thoroughly; do not attempt shortcuts.

CONTENTS

	Page
SPECIFICATIONS	3
GENERAL SPECIFICATIONS - 4500, 4600, 4700	3
REPAIR SPECIFICATIONS	3
TESTS AND ADJUSTMENT SPECIFICATIONS	6
OPERATIONAL TESTS	7
TORQUE VALUES, NON-STANDARD FASTENERS	7
SPECIAL TOOLS	8
OTHER MATERIALS	8
THEORY OF OPERATION	9
COOLING SYSTEM OPERATION	9
LUBRICATION SYSTEM OPERATION	10
FUEL AND AIR SYSTEM OPERATION	11
ENGINE SYSTEM DIAGNOSIS	12
TROUBLESHOOTING CHART	13
TROUBLESHOOTING CHART	14
TESTS AND ADJUSTMENTS	15
CYLINDER COMPRESSION TEST	15
SLOW IDLE ADJUSTMENT	15
VALVE CLEARANCE CHECK AND ADJUSTMENT	16
CONNECTING ROD SIDE PLAY CHECK	17
CONNECTING ROD BEARING CLEARANCE CHECK	17
CRANKSHAFT END PLAY CHECK	18
CRANKSHAFT MAIN BEARING CLEARANCE CHECK	18
VALVE LIFT CHECK	19
CAMSHAFT END PLAY CHECK	20
TIMING GEAR BACKLASH CHECK	20
FUEL INJECTION NOZZLE TEST	20
THERMOSTAT OPENING TEST	22
INJECTION PUMP STATIC TIMING ADJUSTMENT	22
FAN/ALTERNATOR DRIVE BELT ADJUSTMENT	24
RADIATOR BUBBLE TEST	24
COOLING SYSTEM PRESSURE TEST	24
RADIATOR CAP PRESSURE TEST	25
ENGINE OIL PRESSURE TEST	25
AIR INTAKE SYSTEM LEAKAGE TEST	26
FUEL SUPPLY PUMP PRESSURE TEST	26
FUEL SYSTEM LEAKAGE TEST	27
BLEED FUEL SYSTEM	27
REPAIR	27
ENGINE REMOVAL	27
ROCKER COVER	28
EXHAUST MANIFOLD	28
INTAKE MANIFOLD	28
ROCKER ARM ASSEMBLY	29



THEORY OF OPERATION

COOLING SYSTEM OPERATION

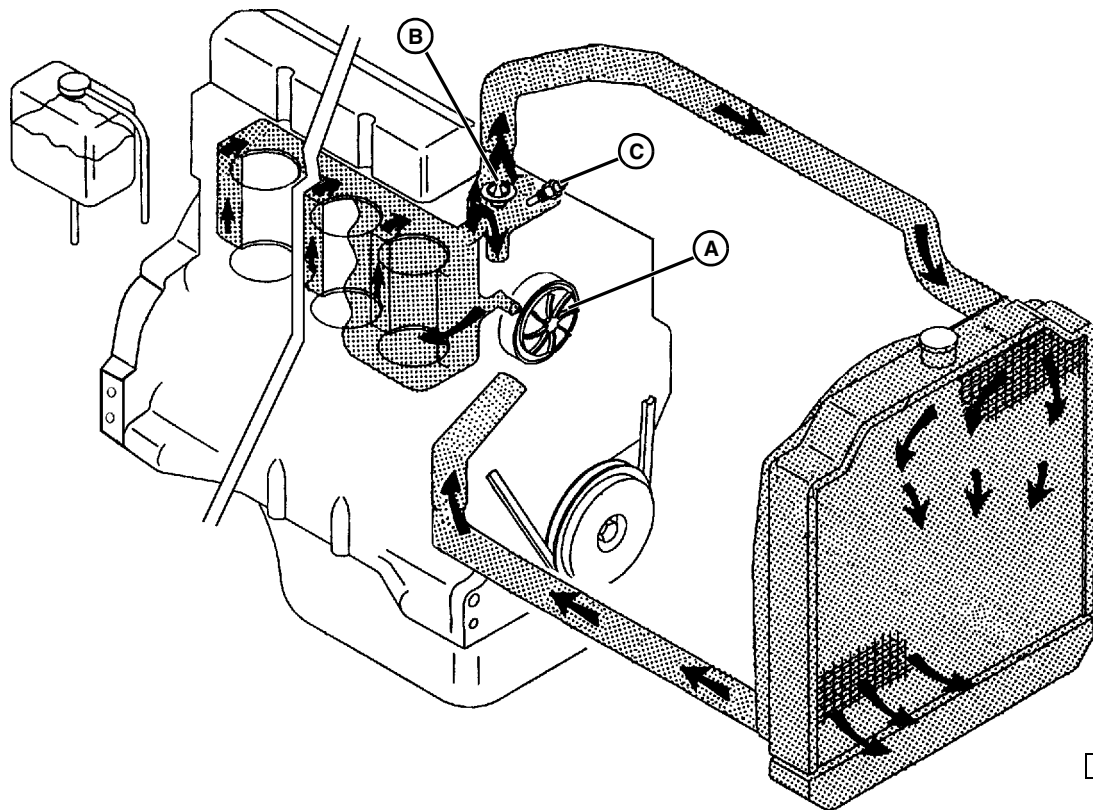

MX1026

Function:

The coolant pump (A) circulates coolant through the cooling system, drawing hot coolant from the engine block, circulating it through the radiator for cooling.

Theory of Operation:

The pressurized cooling system includes the radiator, water pump, fan and thermostat (B).

During the warm-up period, the thermostat remains closed and the impeller type coolant pump draws coolant from the bypass tube. Coolant from the pump flows to the cylinder block water jacket and up through the cylinder head providing a fast warm-up.

Once the engine has reached operating temperature, the thermostat opens and coolant is pumped from the bottom of the radiator via the lower radiator hose into the cylinder block. Here it circulates through the block and around the cylinders.

From the block, coolant is then directed through the cylinder head, and into thermostat housing. With the thermostat open;

Start To Open 69.5 - 72.5° C (157 - 163° F)

Fully Opened 85° C (185° F)

warm engine coolant passes through the housing into the top of the radiator where it is circulated to dissipate heat.

When coolant system pressure exceeds **48 kPa (7 psi)**, a valve in the radiator cap opens to allow coolant to discharge into the coolant recovery tank.

When temperature is reduced, a vacuum is produced in the radiator and coolant is drawn back out of the coolant recovery tank through a valve in the radiator cap.

A coolant temperature sensor (C) informs the operator of the engine coolant temperature and warns of a high temperature condition by lighting a lamp.

LUBRICATION SYSTEM OPERATION

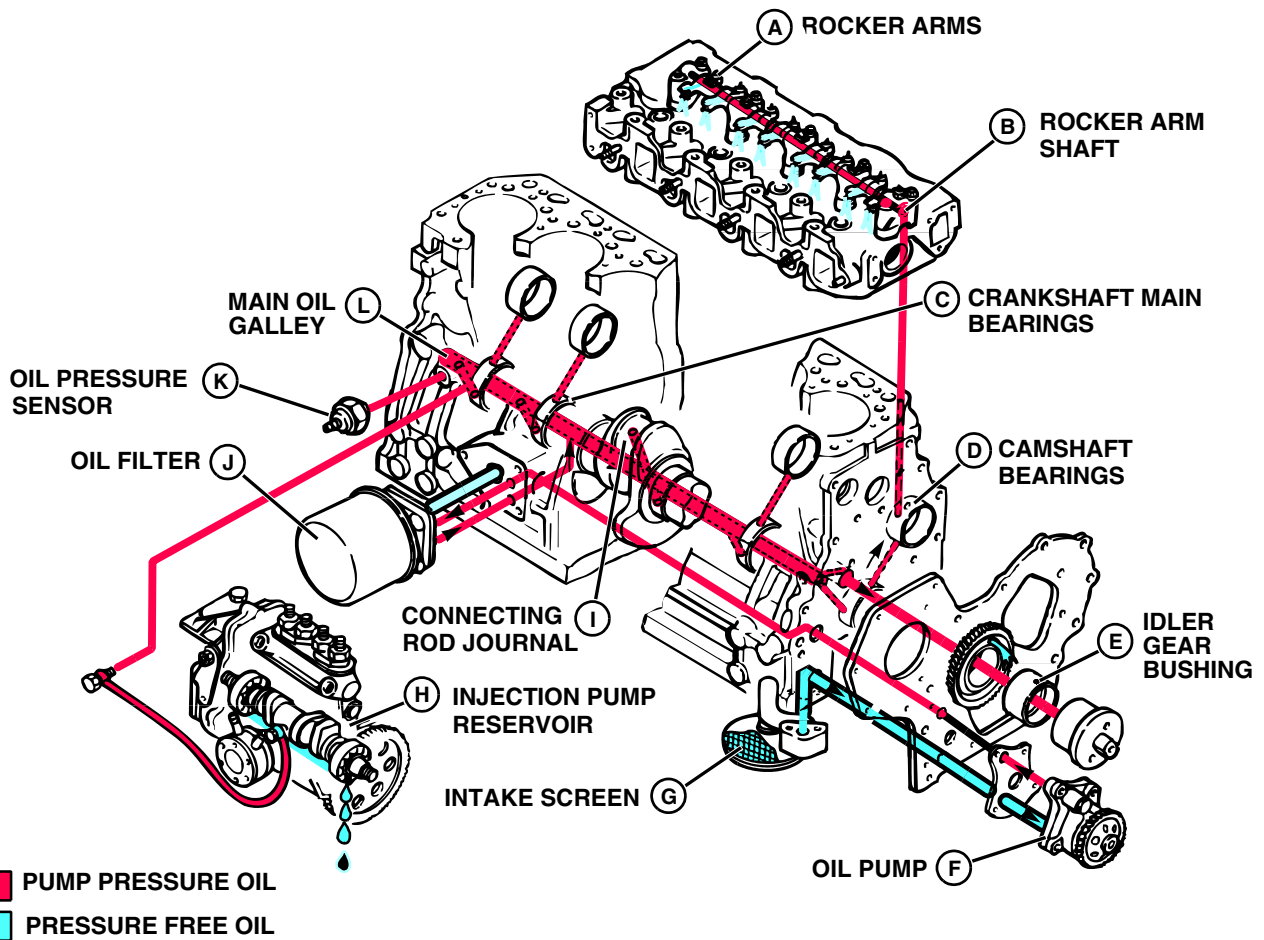
**Function:**

A full pressure system lubricates engine parts with filtered oil.

Theory of Operation:

The pressure lubrication system consists of a positive displacement gear-driven pump (F), oil strainer (G), full flow oil filter (J), oil pressure regulating valve and an electrical pressure warning switch. (K)

The pump draws lubrication oil from the oil pan through a strainer and a suction tube. The oil is then pumped through an oil passage to the oil filter and through the engine block main oil galley (L).

From the main oil galley, oil is forwarded under pressure to the crankshaft main bearing journals (C) and idler gear bushing (E). Drilled cross-passages in the crankshaft (I) distribute the oil from the main bearings to connecting rod bearings.

Lube oil holes in main bearing oil grooves direct oil to the camshaft bearings (D).

A drilled passage from the rear camshaft bearing through the cylinder block and cylinder head supplies lubricating oil to the rocker arm shaft (B). The hollow shaft distributes oil to the rocker arms (A), cam followers and valves.

Lubrication oil is supplied to the fuel injection pump (H) from the main oil galley through external oil lines.

An oil pressure sensor (K) activates an indicator light to alert the operator to shut down the engine if oil pressure drops below specification.

FUEL AND AIR SYSTEM OPERATION

Function:

Fuel system supplies fuel to injection nozzles.

The air intake system filters and supplies air needed for combustion.

Theory of Operation:

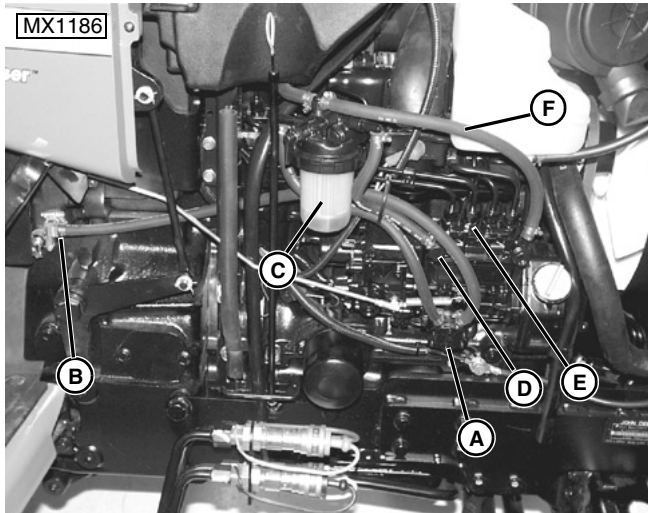

Fuel System:

A mechanical fuel transfer pump (A) draws fuel from the tank outlet (B). The low pressure fuel from the fuel pump flows through the filter/water separator (C) to the fuel the injector pump inlet (D). The injection pump then directs high pressure fuel through the injector lines (E) for combustion. Excess fuel is returned, along with fuel from the injectors, through the return line (F) to the fuel tank.

If the unit runs out of fuel, there are two air bleed lines that allow air to escape from the top of the filter and the injection pump. These two lines allow the system to be self bleeding.

The engine speed is controlled by the throttle lever and rod. The rod is connected to the injection pump governor control lever. The fuel shutoff solenoid controls the injection pump shutoff shaft. When the solenoid is retracted (key in the START or ON position), the engine can be started. When the key is turned off, return springs on the shutoff shaft, extend the solenoid, moving the shutoff linkage to the shutoff position. The solenoid also closes if the tractor is operated in an unsafe condition. (See "ENGINE SHUTOFF CIRCUIT OPERATION" in the Electrical section.)

The injection pump meters fuel as determined by the governor and delivers it at high pressure to the injection nozzles.

The injection nozzle prevents flow until high pressure is reached, opening the valve and spraying atomized fuel into the combustion chamber. Injection lines contain trapped fuel whenever injection is not taking place.

A small amount of fuel leaks past the nozzle valve to lubricate the fuel injection nozzle. This leakage combines with excess fuel from the injection pump and is returned to tank. Any air in the fuel system is bled out with return fuel to the fuel tank.

A fuel level sensor mounted in the fuel tank informs the operator of the fuel level.

Air Intake System:

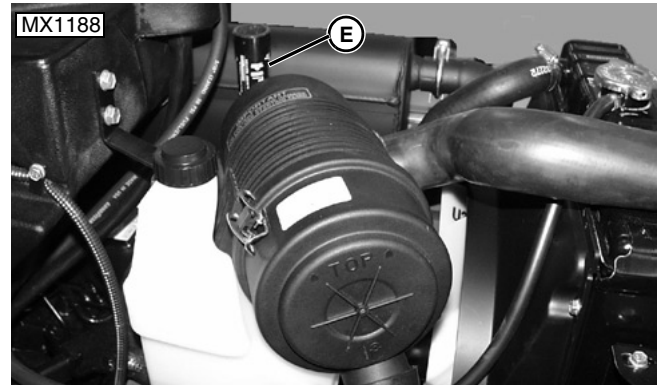
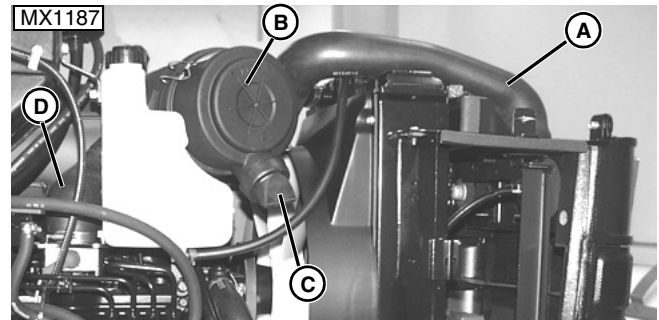

Engine intake air enters the inlet hose (A) behind the grille, and flows into the air filter body (B). The air cleaner also has a rubber, one way, unloading valve (C), that ejects heavy dirt particles from the air stream during engine operation before they reach the filters. The operator can squeeze the valve to remove the large particles. The air cleaner elements filter the air, which then flows through hose (D) to the intake manifold.

An air filter restriction indicator (E) at the rear of the air cleaner informs the operator when the air filter needs servicing.



ENGINE SYSTEM DIAGNOSIS

Conditions:

- Machine parked on level surface
- Park brake engaged
- Key switch in OFF position
- Transmission in NEUTRAL



Test/Check Point	Normal	If Not Normal
1. Engine dipstick and exterior engine surface.	Oil level is between “L” and “H” marks. Oil filter clean.	Fill oil to correct level. Change oil and filter.
	Oil is not burnt, or contaminated with metal particles, fuel, or coolant.	Change oil and filter. Inspect for source of contamination.
	No external leakage.	Check gaskets, seals, plugs, cylinder head, block, intake manifold and breather.
2. Coolant tank and radiator.	Coolant level is between marks on tank when engine is warm. Coolant in radiator is full to top.	Add proper coolant.
	Coolant is not contaminated with oil, fuel or discolored brown.	Drain and flush system. Check for source of contamination.
	Radiator screen free of debris.	Clean or replace.
	Water pump not leaking.	Inspect water pump.
	Hoses not cracked or leaking.	Pressure test radiator and cap.
	Clamps and radiator cap tight.	Tighten cap and clamps.
	Fan belt tight, not glazed or cracked.	Replace belt and adjust tension.
	Fan blades not damaged or warped.	Replace fan.
3. Fuel tank, pump, lines, filter shutoff valve.	Fuel level correct, not contaminated. Correct grade of fuel, no water in fuel.	Drain and clean fuel tank. Add fresh fuel.
	Fuel pump in-line filter free of debris.	Replace filters.
	Fuel shutoff valve in “ON” position.	Move to “ON” position.
	Fuel hoses not cracked or leaking.	Replace.
	Fuel hose clamps tight.	Replace or tighten clamp.
4. Air filter and air intake.	Air filter hose not cracked, clamps tight. Element not plugged. Air filter housing sealed, no dirt tracking inside filter element.	Replace and tighten clamps. Replace element or housing.
5. Fuel shutoff solenoid. (Key in RUN position.)	Fuel shutoff solenoid must pull in and stay in. Solenoid must bottom out. Shutoff shaft must still move slightly.	Clean any dirt from under solenoid boot. If solenoid will not pull in and hold in, See “FUEL SHUTOFF SOLENOID CIRCUIT DIAGNOSIS” in Electrical section.

TESTS AND ADJUSTMENTS

CYLINDER COMPRESSION TEST

Reason:

To determine the condition of the pistons, rings, cylinder walls and valves.

Equipment:

- JT01682 Compression Gauge Assembly
- JDG560 Adapter

Procedure:

1. Remove the injection nozzles.

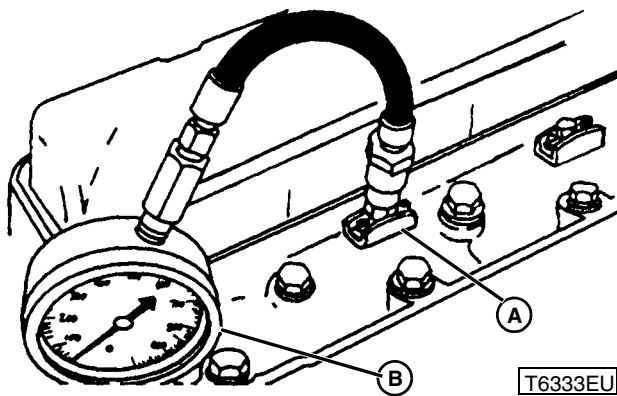

2. Install the heat protector from end of injector and install JDG560 adapter (A).
3. Install JT01682 Compression Gauge Assembly (B) and JDG560 Adapter.
4. Disconnect the fuel control solenoid connector.

IMPORTANT: DO NOT overheat starting motor during test.

5. Crank the engine for five seconds with the starting motor. Minimum cranking speed is 250 rpm.
6. Record the pressure reading for each cylinder.

Compression Pressure:

Standard 3233 ± 97 kPa (469 ± 14 psi)

Minimum 2551 ± 97 kPa (369 ± 14 psi)

Maximum difference between cylinders 248 ± 48 kPa (36 ± 7 psi)

Results:

- If the pressure reading is below specification, squirt clean engine oil into the cylinders through the injector ports and repeat the test.
- If the pressure increases significantly, check piston, rings, and cylinder walls for wear or damage.

- If the pressure does not increase significantly, check for leaking valves, valve seats or cylinder head gasket.

SLOW IDLE ADJUSTMENT

IMPORTANT: The slow idle adjustment is the only adjustment that can be made on this engine.

The fast idle and torque capsule adjustments are pre-set by the engine manufacturer to comply with strict EPA/CARB emissions requirements, and are adjustable **ONLY** by authorized diesel service facilities.



Reason:

To achieve proper slow idle rpm setting. Provides adequate rpm to keep the engine running smoothly without stalling.

Equipment:

- JT05719 Hand Held Digital Tachometer

NOTE: Make sure the air cleaner is clean and not restricted. Replace the air cleaner element as necessary.

Procedure:

1. Place a small piece of reflective tape on the crankshaft pulley.
2. Start the engine and run for 5 minutes to attain operating temperature.
3. Move the throttle lever to slow idle position.
4. Use JT05719 Hand Held Digital Tachometer to check engine speed at the crankshaft pulley.
5. Visually check that the injection pump throttle lever is against slow idle stop screw. Slow idle speed is **950 ± 50 rpm.**

Results:

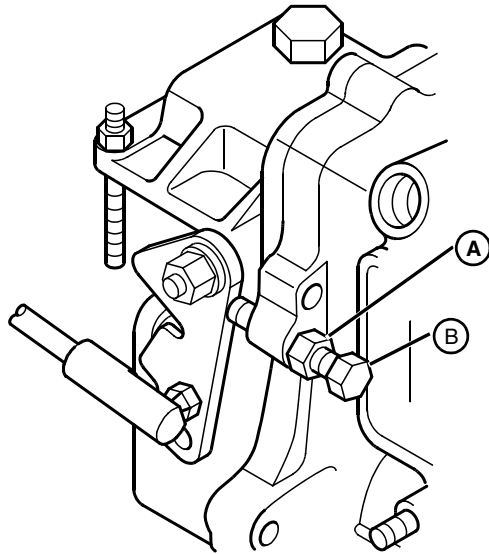

- If the slow idle rpm is not according to specifications, loosen the nut (A) and turn the slow idle stop screw (B). After adjustment, tighten the nut.

VALVE CLEARANCE CHECK AND ADJUSTMENT

Reason:

To achieve correct engine operation.

Equipment:

- Feeler Gauge

Procedure:

1. Remove the rocker arm cover.
2. Remove the access cover from the timing hole in the flywheel housing.

NOTE: "Top Dead Center" (TDC) is the piston at its highest point.

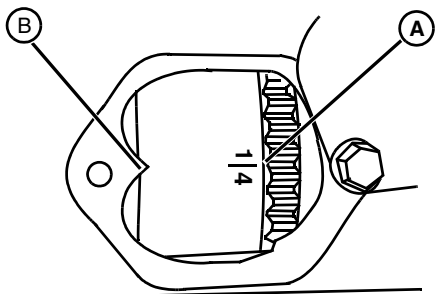

3. Turn the crankshaft pulley clockwise until No.1 cylinder TDC mark on the flywheel (A) aligns with the index mark on the flywheel housing (B) or plate.
4. Try to move both No. 1 cylinder rocker arms or push rods.

NOTE: If the rocker arm push rods are not loose, rotate flywheel one revolution (360°). If both rocker arm push rods are loose, the piston is at TDC on compression stroke.

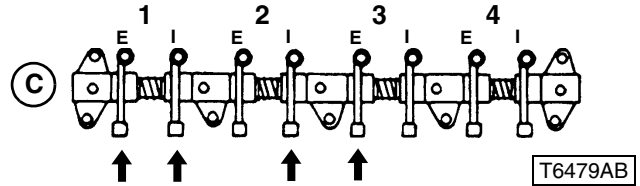

NOTE: No. 1 cylinder is the closest to the flywheel side of the engine (C).

5. Measure and adjust the valve clearance on the valves (arrows) with No. 1 piston at TDC.

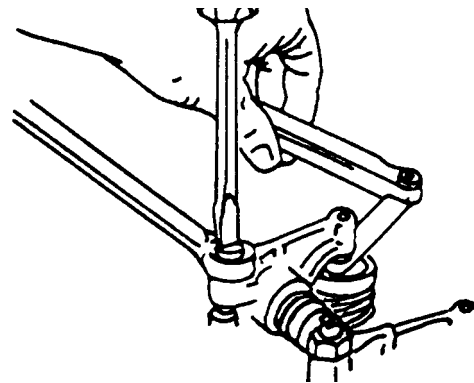

6. To adjust the valves, loosen the nut and turn the adjusting screw until the clearance is 0.15 - 0.25 mm (0.006 - 0.010in.). Hold the screw while tightening the nut.
7. Turn the crankshaft pulley one revolution (360°).

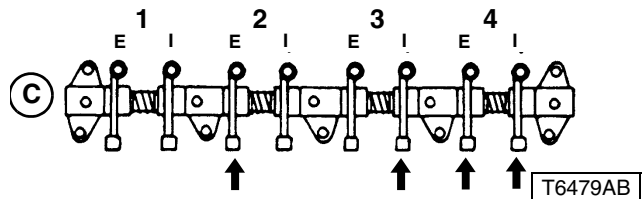

8. Measure and adjust the valve clearance on the valves (arrows) shown.

CONNECTING ROD SIDE PLAY CHECK

Reason:

To determine proper side clearance between the crankshaft and the connecting rod.

Equipment:

- Feeler Gauge

NOTE: The engine must be removed from the tractor to perform this test.

Procedure:

1. Remove the oil pan, crankcase extension, oil pick-up, and balancer assembly.
2. Insert a feeler gauge, according to specifications, between the connecting rod cap and the crankshaft.

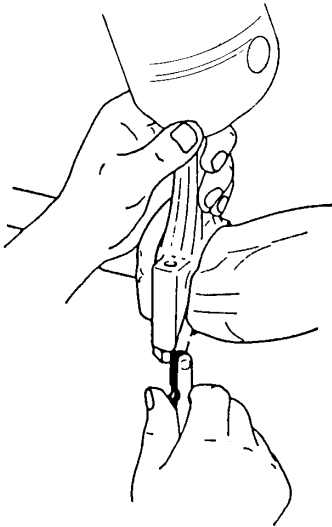

M82116A

3. Connecting rod side play is **0.2 - 0.4 mm (0.008 - 0.016 in.)**.

Results:

- If the side play exceeds specification, replace the bearing inserts or the connecting rod.

CONNECTING ROD BEARING CLEARANCE CHECK

Reason:

To measure oil clearance between connecting rod bearing and crankshaft journal.

Equipment:

- PLASTIGAGE®

NOTE: The engine must be removed from the tractor to perform this test.

Procedure:

1. Remove the oil pan, crankcase extension, oil pick-up, and balancer assembly.

IMPORTANT: The connecting rod caps must be installed on the same connecting rod and in the same direction to prevent crankshaft and connecting rod damage.

2. Remove the connecting rod cap.
3. Wipe oil from the bearing insert and the crankshaft journal.
4. Put a piece of PLASTIGAGE (A), or an equivalent, along the full length of the bearing insert approximately **6 mm (0.25 in.)** off center.

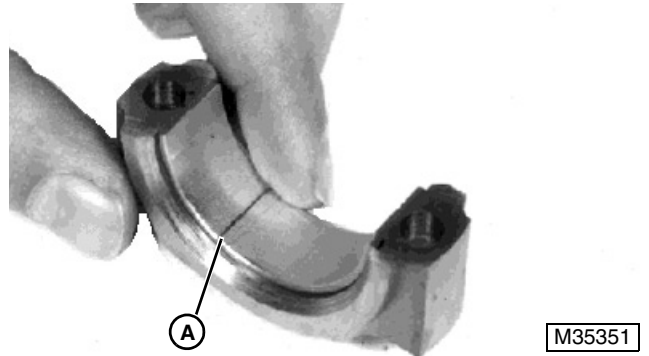

5. Turn the crankshaft approximately 30° from bottom dead center.
6. Install the connecting rod end cap and original rod bolts. Tighten the rod bolts to **44-54 N•m (33-40 lb-ft)**.
7. Remove the rod bolts and the connecting rod cap.

NOTE: The flattened PLASTIGAGE (B) will be found on either the bearing insert or crankshaft journal.

8. Use the graduation marks on the envelope (C) to compare the width of the flattened PLASTIGAGE at its widest point. The number within the graduation marks indicates the bearing clearance in inches or millimeters depending on which side of the envelope is used.

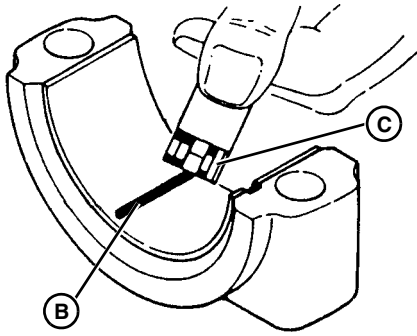

M82117A

9. The bearing clearance is **0.04 - 0.07 mm (0.002 - 0.003 in.)**.
10. Remove the PLASTIGAGE.
 ®PLASTIGAGE is a registered trademark of the DANA Corporation.

Results:

- If the clearance exceeds specification, replace bearing inserts.

CRANKSHAFT END PLAY CHECK

Reason:

To determine proper side clearance between the crankshaft and the engine block.

Equipment:

- Dial Indicator

Procedure:

NOTE: Crankshaft end play can be measured at front end or rear end of crankshaft. Procedure is performed from the rear end. The flywheel is removed to show detail.

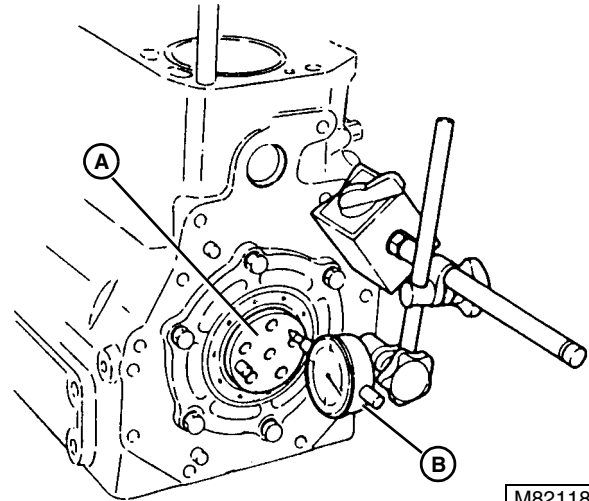

M82118A

1. Fasten the dial indicator (B) to engine and position indicator tip on end of crankshaft (A).

IMPORTANT: Do not use excessive force when moving crankshaft to avoid damaging bearings.

2. Push the crankshaft toward rear as far as possible.
3. Zero the dial indicator.
4. Using a bar, gently pry the crankshaft as far forward as possible.
5. Crank shaft end play is **0.09 - 0.27 mm (0.004 - 0.011 in.)**.

Results:

- If the end play exceeds **0.33 mm (0.013 in.)**, replace the thrust bearings.

CRANKSHAFT MAIN BEARING CLEARANCE CHECK

Reason:

To measure oil clearance between main bearing and crankshaft journal.

Equipment:

- PLASTIGAGE®

NOTE: The engine must be removed from the tractor to perform this test.

Procedure:

1. Remove the oil pan, oil pick-up, crankcase extension, and balancer assembly.

IMPORTANT: Main bearing caps must be installed to the same location and in the same direction to prevent crankshaft and main bearing damage.

2. Remove the main bearing cap.
3. Wipe oil from the bearing insert and the crankshaft journal.
4. Put a piece of PLASTIGAGE (A), or equivalent, along the full length of the bearing insert approximately **6 mm (0.25 in.)** off center.

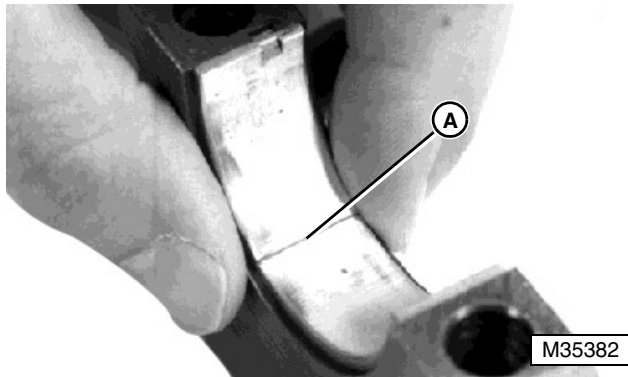

5. Install main bearing cap and bolts. Tighten bolts to **96 - 100 N•m (71 - 74 lb-ft)**.
6. Remove bolts and main bearing cap.

NOTE: The flattened PLASTIGAGE will be found on either the bearing insert or crankshaft journal.

7. Use the graduation marks on the envelope (C) to compare the width of the flattened PLASTIGAGE (B) at its widest point. The number within the graduation marks indicates the bearing clearance in inches or millimeters depending on which side of the envelope is used.

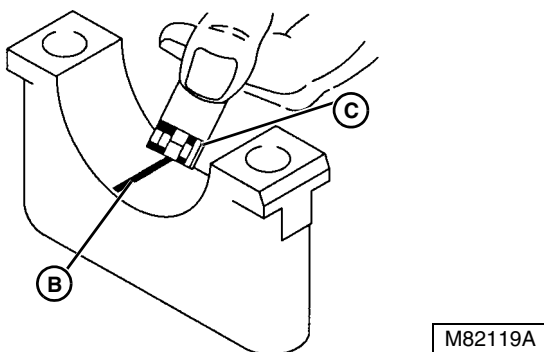

8. Main bearing clearance is **0.04 - 0.07 mm (0.001 - 0.003 in.)**.
9. Remove PLASTIGAGE.
PLASTIGAGE® is a registered trademark of the DANA Corporation.

Results:

- If the clearance exceeds **0.15 mm (0.006 in.)** replace the bearing inserts.

VALVE LIFT CHECK

Reason:

Check wear on cam lobes, followers, and/or push rods.

Equipment:

- Dial Indicator

Procedure:

1. Remove the rocker arm cover. (See "ROCKER COVER" on page 28.)
2. Adjust the valve clearance. (See "VALVE CLEARANCE CHECK AND ADJUSTMENT" on page 16.)

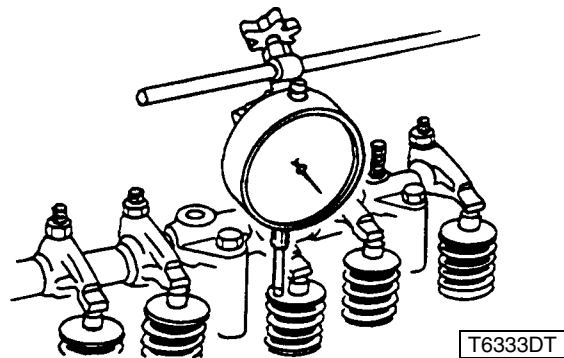

3. Fasten the dial indicator to the engine and position the indicator tip on the valve retainer. The valve must be fully closed and the rocker arm must move freely.
4. Zero the dial indicator.
5. Manually turn the crankshaft pulley clockwise (from the fan end).
6. Observe the dial indicator as the valve is moved to the full open position.
7. Repeat for each valve.

Results:

- The valve lift should be the same for all the valves. If one or more valves show less lift than the others, remove and inspect the camshaft, followers and push rods. (See "CAMSHAFT" on page 48.) If the camshaft, followers, and pushrods are within specification, remove cylinder head for inspection. (See "CYLINDER HEAD AND VALVES" on page 31.)

CAMSHAFT END PLAY CHECK

Reason:

To determine proper side clearance between camshaft gear end journal and thrust plate.

Equipment:

- Dial Indicator

Procedure:

1. Remove the timing gear cover. (See "TIMING GEAR COVER" on page 52.)
2. Fasten the dial indicator to the engine and position indicator tip on end of camshaft.
3. Push the camshaft toward the rear as far as possible.
4. Zero the dial indicator.
5. Pull the camshaft forward as far as possible.

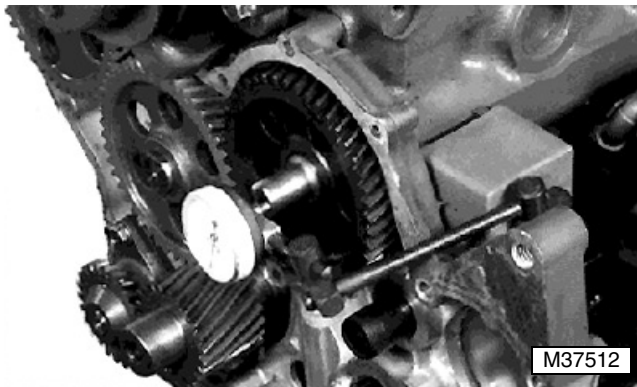

6. Standard end play is **0.05 - 0.25 mm (0.002 - 0.010 in.)**.

Results:

- If the end play exceeds **0.25 mm (0.010 in.)**, remove the camshaft and replace the thrust plate. (See "CAMSHAFT" on page 48.)

TIMING GEAR BACKLASH CHECK

Reason:

To check for wear between meshing gears, resulting in excessive noise and poor engine performance.

Equipment:

- Dial Indicator

Procedure:

1. Measure the backlash between meshing gears.
2. The backlash for all gears, EXCEPT the oil pump gear, is **0.07 - 0.15 mm (0.003 - 0.005 in.)**.
3. The backlash for the oil pump gear is **0.11 - 0.19 mm (0.004 - 0.008 in.)**.

Results:

- If the backlash exceeds specifications, replace meshing gears as a set:

Idle Gear, Camshaft Gear, Crankshaft Gear, Oil Pump Gear AND/OR Idle Gear, Fuel Injection Pump Gear.

FUEL INJECTION NOZZLE TEST

CAUTION

Escaping fluid under pressure can penetrate the skin causing serious injury. Avoid the hazard by relieving pressure before disconnecting hydraulic or other lines. Tighten all connections before applying pressure. Search for leaks with a piece of cardboard. Protect hands and body from high pressure fluids.

If an accident occurs, see a doctor immediately. Any fluid injected into the skin must be surgically removed within a few hours or gangrene may result. Doctors unfamiliar with this type of injury should reference a knowledgeable source. Such information is available from the Deere & Company Medical Department in Moline, Illinois, U.S.A.

Reason:

To determine opening pressure, leakage, chatter and spray pattern of the fuel injection nozzle.

Equipment:

- D01109AA Diesel Fuel Injection Nozzle Tester
- D01110AA Adapter Set
- 23622 Straight Adapter
- Container

Connections:

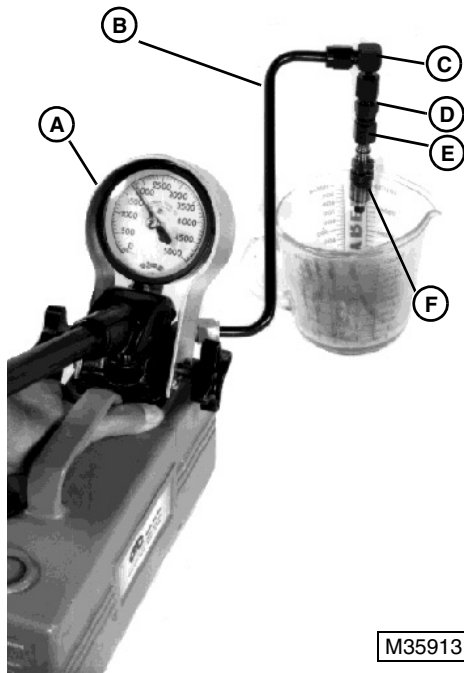

1. Connect the fuel injection nozzle (F) to D01109AA Diesel Fuel Injection Nozzle Tester (A) using parts 36352 (B), 23617 (C), 23621 (D) from D01110AA Adapter Set, and 23622 straight adapter.

IMPORTANT: Use clean filtered diesel fuel when testing injection nozzles to get best test results.

Procedure 1:

Test the fuel injection nozzle **opening pressure** following the Nozzle Tester manufacturer's instructions.

The opening pressure is **19600 +1000/-0 kPa (2843 +145/-0 psi)**.

Results:

- If the pressure reading does not meet specification, disassemble the injection nozzle and inspect for contamination or a stuck valve. If necessary, add or remove shims to change opening pressure.

Procedure 2:

Test fuel injection nozzle **leakage** following the nozzle tester manufacturer's instructions.

1. Dry the nozzle completely using a lint-free cloth.
2. Pressurize the nozzle to **19600 kPa (2843 psi)**.
3. Watch for leakage from nozzle spray orifice.

Results:

- Fuel should not leak from the nozzle when the nozzle is pressurized.

- If the injection nozzle leaks fuel, disassemble and inspect the nozzle assembly for contamination. Inspect the valve seating surface. Replace the nozzle assembly if necessary.

Procedure 3:

1. Test the fuel injection nozzle **chatter and spray pattern** following the nozzle tester manufacturer's instructions.
2. Pressurize nozzle to **19600 kPa (2843 psi)**.
3. With slow hand lever movement there should be a "chatter" sound.
4. With fast hand lever movement the nozzle should exhibit an even, fine atomized spray pattern (G).
5. Place a sheet of white paper **30 cm (12 in.)** below the nozzle. The injection spray should form a perfect circle on the paper.

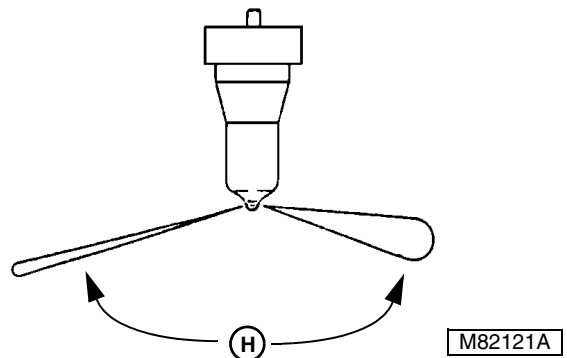
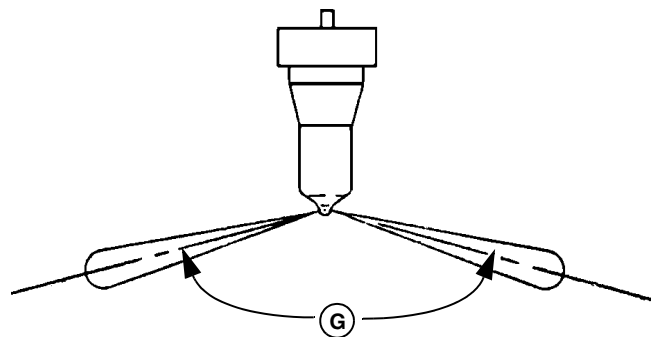

Results:

- If nozzle chatter or the spray pattern does not meet specifications, disassemble the injection nozzle and inspect the nozzle assembly for contamination. Inspect the valve seating surface. Replace the nozzle assembly if necessary.
- If there is excessive difference in the spray angle or injection angle, incomplete atomizing or sluggish starting/stopping of injection (H), disassemble the injection nozzle and inspect the nozzle assembly for contamination. Replace the nozzle assembly if necessary.

THERMOSTAT OPENING TEST

Reason:

To determine opening temperature of thermostat.

Equipment:

- Thermometer
- Glass Container
- Heating Unit

Procedure:



CAUTION

DO NOT allow thermostat or thermometer to rest against the side or bottom of glass container when heating water. Either may rupture if overheated.

1. Suspend the thermostat (B) and a thermometer (A) in a container of water.
2. Heat and stir the water. Observe opening action of the thermostat and compare temperatures with specifications.
3. Remove the thermostat and observe the closing action as it cools.

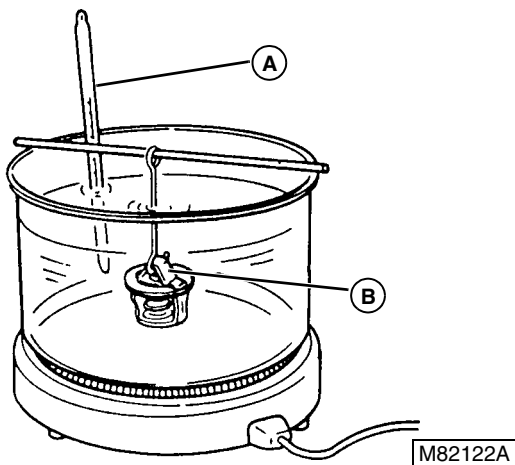

Results:

- The thermostat should begin opening at **69.5 - 72.5° C (157 - 163° F)** and be fully open at **85° C (185° F)**.
- Replace the thermostat if the lift height is less than **8 mm (0.315 in.)**, or if the closing action is not smooth and slow.

INJECTION PUMP STATIC TIMING ADJUSTMENT

Reason:

To make sure that the injection pump timing is set to manufacturers specification.

Equipment:

- Timing Tool (Made from high pressure pipe, nut and a clear plastic straw**)
- ** straw from WD40, carburetor cleaner, brake parts cleaner, etc.
- External fuel supply

Procedure:

IMPORTANT: The injection pump timing should be correct. The timing is set at the factory, and will not normally change during the life of the engine. Check and adjust the timing only as the last option, or if there is reason to believe the timing has been altered. Check the fuel, fuel supply system, injectors, air intake system and cylinder compression before continuing.

NOTE: If the injection pump has been removed from engine without disturbing engine crankshaft and pump gear, perform step 1 to obtain a close starting point, then perform the entire timing procedure.

1. Align the arrow or line on the injection pump flange on the mark noted during pump removal.

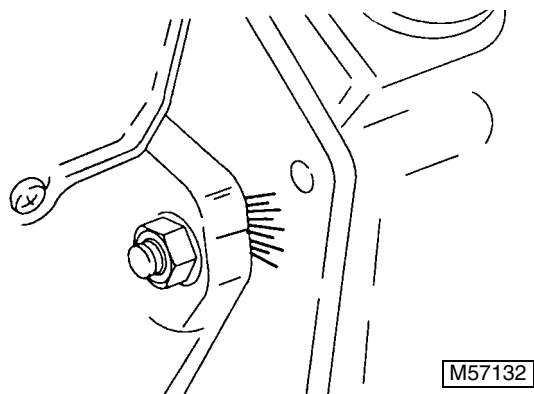

NOTE: Normal rotation, as viewed from the flywheel end, is counterclockwise. The number one fuel injection line is toward the flywheel.

2. Remove the number one fuel injection line.

**Thank you very much for
your reading. Please Click
Here. Then Get COMPLETE
MANUAL. NO WAITING**



NOTE:

**If there is no response to
click on the link above,
please download the PDF
document first and then
click on it.**

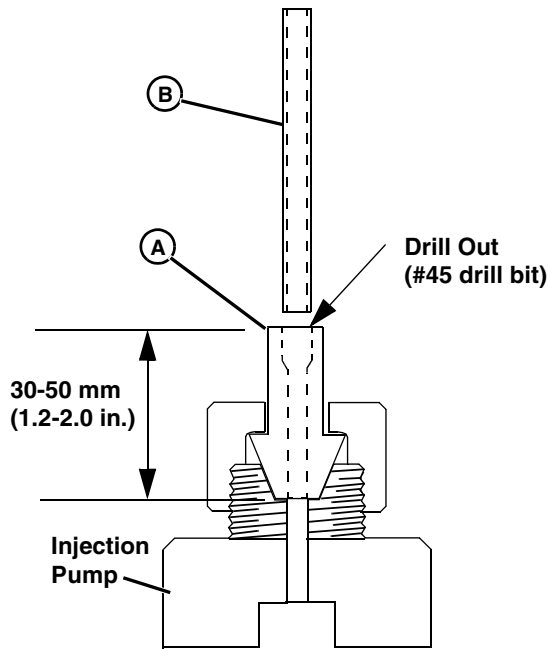

3. Install the timing tool (A) and clear straw (B).
4. Remove the access panel from the flywheel housing.
5. Prime the pump to fill it with fuel.
6. Disconnect battery negative (-) terminal and remove fuel shutoff solenoid.
7. Turn the flywheel counterclockwise (as viewed from the flywheel end) until the timing tool straw has fuel showing.

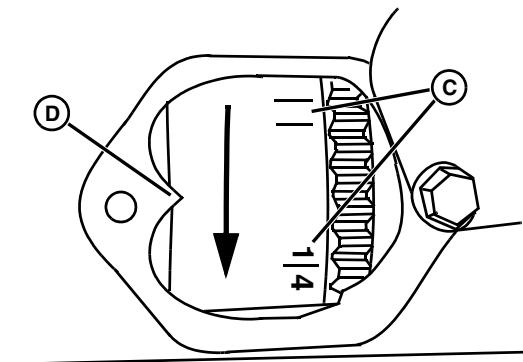

8. Turn the crankshaft pulley clockwise (back) until the No. 1 cylinder top dead center (TDC) mark and pump timing marks (C) have gone past the index mark on the flywheel housing/plate (D) by at least 50 mm (2 in.).
9. Snap the straw with your finger until the level of the fuel, or a bubble, is set part way up the straw. This will be the point to watch for fuel movement.

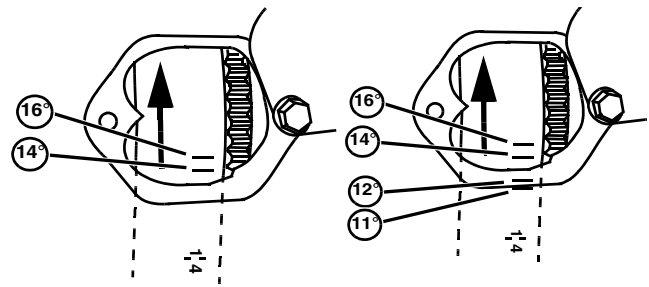

JTC45-6-7 Engines

EJTF45-6-7S Engines

10. Slowly turn the flywheel counterclockwise (as viewed from the flywheel end) until the fuel in the straw just starts to move. Stop rotating the flywheel the instant the fuel begins to move.

NOTE: If there is no fuel movement, engine may be on exhaust stroke. Rotate flywheel 360° and repeat test.

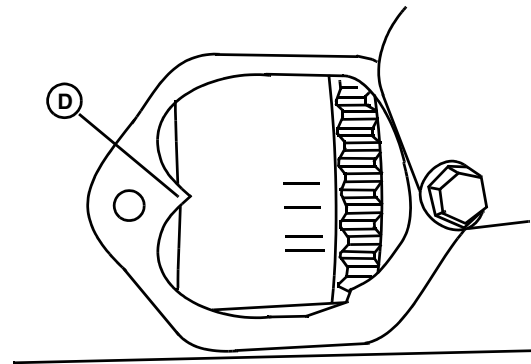

11. Check the injection pump timing marks on the flywheel. The index mark (D) on the flywheel housing must line with the correct timing mark on flywheel.

Timing Marks:

JTC45-6 Engines 14° BTDC
 EJTF45-6-7S Engines..... 12° BTDC

Results:

- If the timing is not within specifications, loosen the pump mounting bolts and turn the pump toward the engine block to retard the timing or away from the block to advance the timing. Recheck the timing.
 If the timing did not change, remove pump and have tested by an authorized diesel injection service shop.
- If the timing is correct, remove timing tool, install number one injection line, install the access cover to the flywheel housing.

FAN/ALTERNATOR DRIVE BELT ADJUSTMENT

Reason:

To keep proper tension on belt to drive water pump and alternator. To prevent shortened belt and bearing life.

Equipment:

- JDG529 or JDST28 BeltTension Gauge
- Straight Edge

Procedure:

1. Check the belt tension between the fan and alternator using a Belt Tension Gauge and a straight edge.

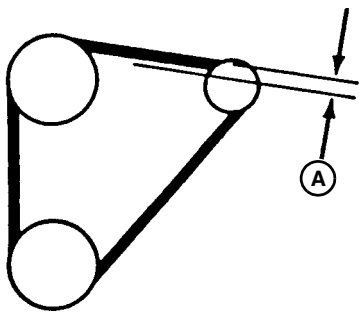

M54014

2. With applied force of **98 N (22 lb-force)** the belt deflection (A) is **10 - 15 mm (0.4 - 0.6 in.)**.

Results:

- If deflection is not within specifications, loosen both alternator mounting cap screws/nuts. Apply force to FRONT alternator housing only (near the belt) until tension is correct. Tighten cap screws/nuts.

RADIATOR BUBBLE TEST

Reason:

To determine if compression pressure is leaking from cylinder.

Equipment:

- JDG560 Adapter

Procedure:

1. With the coolant at the proper level and the radiator cap tight, run the engine for 5 minutes to bring it to operating temperature.
2. Remove the cap from the recovery tank.
3. Check for bubbles coming from the overflow hose at the bottom of the tank.

- If bubbles are present, isolate the source of compression leak:

4. Remove the injection nozzles.
5. Install JDG560 Adapter in the injection port of the cylinder to be tested.
6. Move the piston to the bottom of the stroke with intake and exhaust valves closed.
7. Connect the hose from the compressed air source to adapter.
8. Apply shop air pressure into the cylinder.
9. Check for bubbles in the recovery tank or air escaping from the muffler, air cleaner or oil fill opening.
10. Repeat for each cylinder.

Results:

- If bubbles are present in the recovery tank, check for cracks in the cylinder head and the block. Check for a damaged head gasket.
- If air escapes from the muffler, check for a worn exhaust valve.
- If air escapes from air cleaner, check for a worn intake valve.
- If air escapes from engine oil fill, check for worn piston rings.

COOLING SYSTEM PRESSURE TEST

Reason:

Inspect the cooling system for leaks.

Equipment:

- D05104ST Cooling System Pressure Pump
- JDG692 Radiator Pressure Test Kit (Adapters)

Procedure:

1. Remove the cap and attach the pressure pump (A) to radiator.
2. Apply pressure according to specifications, not to exceed **97 kPa (14 psi)**.
3. Check for leaks throughout the cooling system. After **15 seconds** the minimum pressure is **88 kPa (12.8 psi)**.

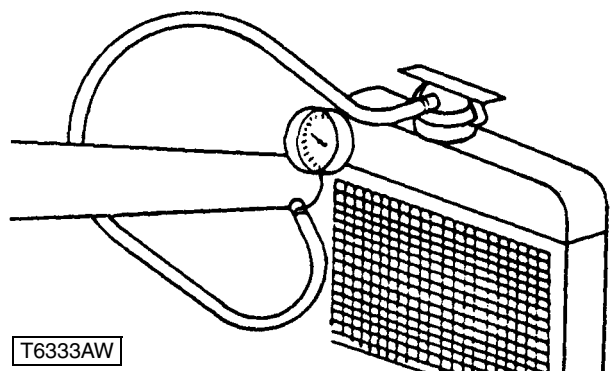

T6333AW

Results:

- Pressure should hold to specifications. If pressure decreases, check for leaks. Repair leaks or replace parts as necessary.
- If the pressure test still indicates leakage after all external leaks have been stopped, a defective head gasket, cracked block, or cylinder head may be the cause. (See "RADIATOR BUBBLE TEST" on page 24.)

RADIATOR CAP PRESSURE TEST**Reason:**

Test the radiator cap for operating in the correct pressure range.

Equipment:

- D05104ST Cooling System Pressure Pump
- JDG692 Radiator Pressure Test Kit (Adapters)

Procedure:

1. Install the radiator cap (B) on the pressure pump (A).
2. Apply pressure. Pressure valve in the cap should open at **88 kPa (12.8 psi)**.

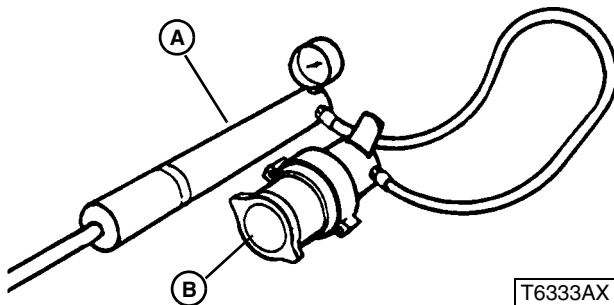
**Results:**

- If the cap leaks, retighten and test again. Replace the cap if pressure is not within specification.

ENGINE OIL PRESSURE TEST**Reason:**

To determine if the engine bearings or the lubrication system components are worn.

Equipment:

- JT03017 Hose Assembly
- JT05577 Pressure Gauge (100 psi)
- JT03349 Connector

Procedure:

1. Remove the oil pressure sender.
2. Install JTO3349 Connector (C).

3. Connect JTO3017 Hose Assembly (B) and JTO5577 Pressure Gauge (A).

IMPORTANT: DO NOT run the engine if there is insufficient oil pressure!

4. Start the engine. If the pressure reading is below **60.0 kPa (8.7 psi)**, **STOP THE ENGINE**.
5. If the oil pressure is at least **60.0 kPa (8.7 psi)**, run the engine approximately five minutes to heat the oil. Check the oil pressure at rated speed. The oil pressure should be **338 ± 50 kPa (49 ± 7.2 psi)**.

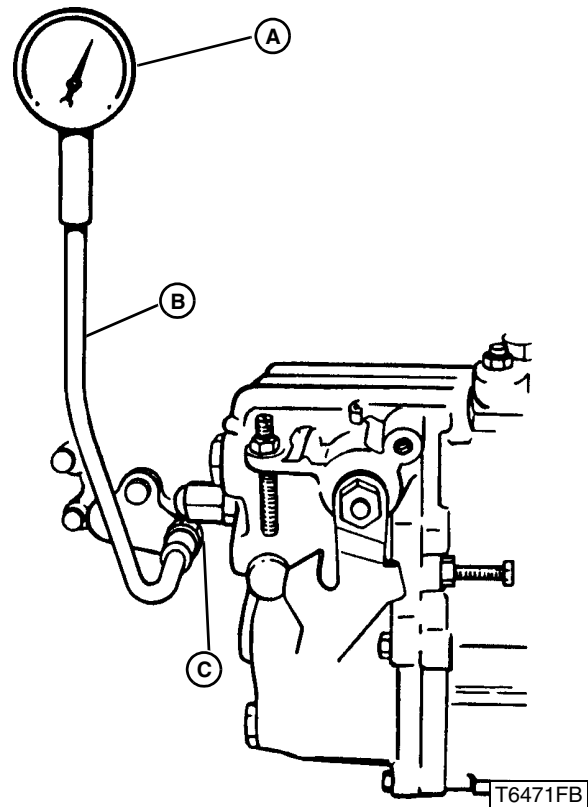
**Results:**

- If the oil pressure is not within specifications, inspect the oil pump.
- If the oil pump is within specifications, the engine may have parts worn beyond specifications. See "TROUBLESHOOTING CHART" on page 13 for more information.