

38, 48 and 54-Inch Commercial Walk-Behind Mowers

TECHNICAL MANUAL

**John Deere
Lawn & Grounds Care Division
TM1488 (01APR96)**

Introduction

FOREWORD

This manual is written for an experienced technician. Essential tools required in performing certain service work are identified in this manual and are recommended for use.

Live with safety: Read the safety messages in the introduction of this manual and the cautions presented throughout the text of the manual.

N This is the safety-alert symbol. When you see this symbol on the machine or in this manual, be alert to the potential for personal injury.

Technical manuals are divided in two parts: repair and diagnostics. Repair sections tell how to repair the components. Diagnostic sections help you identify the majority of routine failures quickly.

Information is organized in groups for the various components requiring service instruction. At the beginning of each group are summary listings of all applicable essential tools, other materials needed to do the job and service parts kits.

Section 10, Group 15—Repair Specifications, consist of all applicable specifications, wear tolerances and specific torque values for various components on each individual machine.

Binders, binder labels, and tab sets can be ordered by John Deere dealers direct from the John Deere Distribution Service Center.

This manual is part of a total product support program.

FOS MANUALS—REFERENCE

TECHNICAL MANUALS—MACHINE SERVICE

COMPONENT MANUALS—COMPONENT SERVICE

Fundamentals of Service (FOS) Manuals cover basic theory of operation, fundamentals of troubleshooting, general maintenance, and basic type of failures and their causes. FOS Manuals are for training new personnel and for reference by experienced technicians.

Technical Manuals are concise guides for specific machines. Technical manuals are on-the-job guides containing only the vital information needed for diagnosis, analysis, testing, and repair.

Component Technical Manuals are concise service guides for specific components. Component technical manuals are written as stand-alone manuals covering multiple machine applications.

Contents

SECTION 10—GENERAL INFORMATION

- Group 05—Safety
- Group 10—General Specifications
- Group 15—Repair Specifications
- Group 20—Fuels and Lubricants
- Group 25—Serial Number Locations
- Group 30—Features & Attachments
- Group 35—Service Information Bulletin Listing

SECTION 20—ENGINE REPAIR

- Group 05—Engine
- Group 10—Muffler

SECTION 30—FUEL AND AIR REPAIR

- Group 05—Fuel System
- Group 10—Air System

SECTION 40—ELECTRICAL REPAIR

- Group 05—Electrical System Components
- Group 10—Electric PTO Clutch

SECTION 50—POWER TRAIN REPAIR

- Group 05—Transaxle
- Group 10—Traction Drive Clutch Assembly

SECTION 60—STEERING AND BRAKE REPAIR

- Group 05—Brake Repair

SECTION 80—MISCELLANEOUS REPAIR

- Group 05—Mower Deck Repair
- Group 10—Drive Wheels

SECTION 210—TEST & ADJUSTMENT SPECIFICATIONS/OPERATIONAL CHECKOUT PROCEDURE

- Group 05—Test and Adjustment Specifications
- Group 10—Operational Checkout Procedures

SECTION 220—ENGINE OPERATION, TESTS AND ADJUSTMENTS

- Group 05—Component Location
- Group 10—Theory of Operation
- Group 15—Diagnosis, Tests, and Adjustments

SECTION 230—FUEL/AIR OPERATION, TESTS & ADJUSTMENTS

- Group 05—Component Location
- Group 10—Theory of Operation
- Group 15—Diagnosis, Tests, and Adjustments

SECTION 240—ELECTRICAL OPERATION, TESTS & ADJUSTMENTS

- Group 05—Component Location
- Group 10—Theory of Operation
- Group 15—Diagnosis, Tests, and Adjustments
- Group 20—Wiring Schematic and Harness Diagram

SECTION 250—POWER TRAIN OPERATION TESTS & ADJUSTMENTS

- Group 05—Component Location
- Group 10—Theory of Operation
- Group 15—Diagnosis, Tests and Adjustments

SECTION 260—STEERING & BRAKES OPERATION TESTS & ADJUSTMENTS

- Group 05—Component Location
- Group 10—Theory of Operation
- Group 15—Diagnosis, Tests & Adjustments

SECTION 280—MISCELLANEOUS OPERATION TESTS & ADJUSTMENTS

- Group 05—Component Location
- Group 10—Theory of Operation
- Group 15—Diagnosis, Tests & Adjustments

INDEX

All information, illustrations and specifications in this manual are based on the latest information available at the time of publication. The right is reserved to make changes at any time without notice.

TM1488-19-01APR96

COPYRIGHT©1996
DEERE & COMPANY
Moline, Illinois
All rights reserved
A John Deere ILLUSTRATION®
Manual
Previous Editions
Copyright© 1993 Deere & Company

Section 10

GENERAL INFORMATION

Contents

	Page		Page
Group 05—Safety		Group 25—Serial Number Locations	
Group 10—Repair Specifications		Serial Numbers	10-25-1
Specifications		Record	
Power Unit	10-10-1	Power Unit Identification Number	10-25-1
Mower Deck	10-10-2	Engine Serial Number	10-25-1
		Transaxle Serial Number	10-25-1
		Mower Deck Serial Number	10-25-2
Group 15—Repair Information		Group 30—Features and Attachments	
Machine Repair Specifications	10-15-1	Features and Attachment Information	10-30-1
Tune-Up		Commercial Walk Behind Mower	
Specifications	10-15-3	Summary	10-30-1
Adjustments	10-15-3	FC400V Engine Features	10-30-2
Metric Fastener Torque Values	10-15-4	FC420V Engine Features	10-30-3
Inch Fastener Torque Values	10-15-5	FC540V Engine Features	10-30-4
		Transaxle Features	10-30-5
Group 20—Fuels, Lubricants, and Coolants		38, 48 and 54-Inch Mower Deck	
North America		Features	10-30-6
Gasoline	10-20-1	Fuel Tank Features	10-30-6
Engine Oil	10-20-3	Operator's Station Features	10-30-7
Break-in Engine Oil	10-20-5	Optional Attachments and Kits	10-30-7
Gear Case Oil	10-20-7		
Alternative Lubricants	10-20-8	Group 35—Service Information Bulletin	
Synthetic Lubricants	10-20-8	Listing	10-35-1
Lubricant Storage	10-20-8		
Mixing of Lubricants	10-20-8		
Oil Filters	10-20-8		
Europe			
Gasoline	10-20-2		
Engine Oil	10-20-4		
Break-in Engine Oil	10-20-6		
Gear Case Oil	10-20-7		
Alternative Lubricants	10-20-9		
Synthetic Lubricants	10-20-9		
Lubricant Storage	10-20-9		
Mixing of Lubricants	10-20-9		
Oil Filters	10-20-9		

RECOGNIZE SAFETY INFORMATION

This is the safety-alert symbol. When you see this symbol on your machine or in this manual, be alert to the potential for personal injury.

Follow recommended precautions and safe operating practices.



DX,ALERT -19-04JUN90

10
05
T81389 -UN-07DEC88

UNDERSTAND SIGNAL WORDS

A signal word—DANGER, WARNING, or CAUTION—is used with the safety-alert symbol. DANGER identifies the most serious hazards.

DANGER or WARNING safety signs are located near specific hazards. General precautions are listed on CAUTION safety signs. CAUTION also calls attention to safety messages in this manual.



DX,SIGNAL -19-04JUN90

TS187 -19-30SEP88

FOLLOW SAFETY INSTRUCTIONS

Carefully read all safety messages in this manual and on your machine safety signs. Keep safety signs in good condition. Replace missing or damaged safety signs. Be sure new equipment components and repair parts include the current safety signs. Replacement safety signs are available from your John Deere dealer.

Learn how to operate the machine and how to use controls properly. Do not let anyone operate without instruction.

Keep your machine in proper working condition. Unauthorized modifications to the machine may impair the function and/or safety and affect machine life.

If you do not understand any part of this manual and need assistance, contact your John Deere dealer.



DX,READ -19-04JUN90

TS201 -UN-23AUG88

HANDLE FLUIDS SAFELY—AVOID FIRES

When you work around fuel, do not smoke or work near heaters or other fire hazards.

Store flammable fluids away from fire hazards. Do not incinerate or puncture pressurized containers.

Make sure machine is clean of trash, grease, and debris.

Do not store oily rags; they can ignite and burn spontaneously.



DX,FLAME -19-04JUN90

TS227 -UN-23AUG88

PREVENT BATTERY EXPLOSIONS

Keep sparks, lighted matches, and open flame away from the top of battery. Battery gas can explode.

Never check battery charge by placing a metal object across the posts. Use a volt-meter or hydrometer.

Do not charge a frozen battery; it may explode. Warm battery to 16°C (60°F).



DX,SPARKS -19-04JUN90

TS204 -UN-23AUG88

PREPARE FOR EMERGENCIES

Be prepared if a fire starts.

Keep a first aid kit and fire extinguisher handy.

Keep emergency numbers for doctors, ambulance service, hospital, and fire department near your telephone.

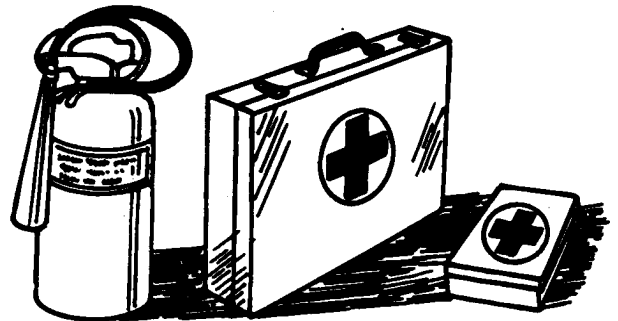

DX,FIRE2 -19-04JUN90

TS291 -UN-23AUG88

PREVENT ACID BURNS

Sulfuric acid in battery electrolyte is poisonous. It is strong enough to burn skin, eat holes in clothing, and cause blindness if splashed into eyes.

Avoid the hazard by:

1. Filling batteries in a well-ventilated area.
2. Wearing eye protection and rubber gloves.
3. Avoiding breathing fumes when electrolyte is added.
4. Avoiding spilling or dripping electrolyte.
5. Use proper jump start procedure.

If you spill acid on yourself:

1. Flush your skin with water.
2. Apply baking soda or lime to help neutralize the acid.
3. Flush your eyes with water for 10—15 minutes. Get medical attention immediately.

If acid is swallowed:

1. Drink large amounts of water or milk.
2. Then drink milk of magnesia, beaten eggs, or vegetable oil.
3. Get medical attention immediately.



DX,POISON -19-04JUN90

PARK MACHINE SAFELY

Before working on the machine:

- Lower all equipment to the ground.
- Stop the engine and remove the key.
- Disconnect the battery ground strap.
- Hang a "DO NOT OPERATE" tag in operator station.

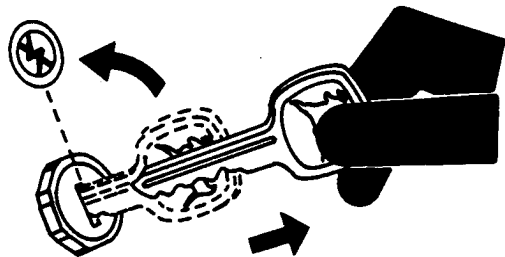

DX,PARK -19-04JUN90

SUPPORT MACHINE PROPERLY

If you must work on a lifted machine or attachment, properly support the machine or attachment.

Do not support the machine on cinder blocks, hollow tiles, or props that may crumble under continuous load. Do not work under a machine that is supported solely by a jack. Follow recommended procedures in this manual.

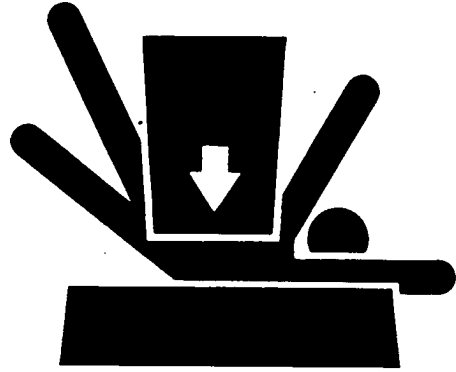

MX,SUPPORT,A -19-05FEB91

TS229 -UN-23AUG88

WEAR PROTECTIVE CLOTHING

Wear close fitting clothing and safety equipment appropriate to the job.

Prolonged exposure to loud noise can cause impairment or loss of hearing.

Wear a suitable hearing protective device such as earmuffs or earplugs to protect against objectionable or uncomfortable loud noises.

Operating equipment safely requires the full attention of the operator. Do not wear radio or music headphones while operating machine.

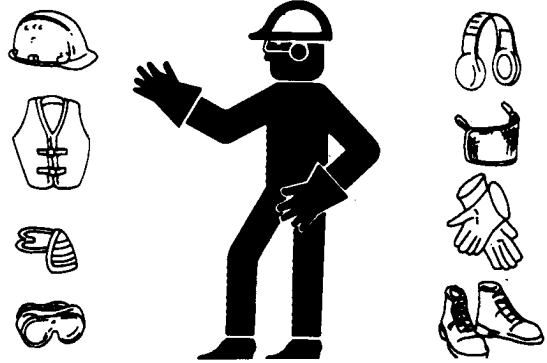

DX,WEAR -19-10SEP90

TS206 -UN-23AUG88

WORK IN CLEAN AREA

Before starting a job:

- Clean work area and machine.
- Make sure you have all necessary tools to do your job.
- Have the right parts on hand.
- Read all instructions thoroughly; do not attempt shortcuts.

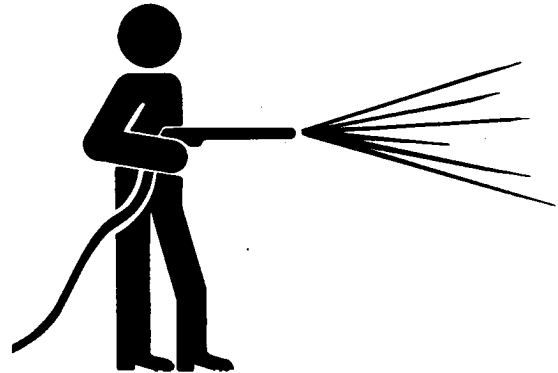

DX,CLEAN -19-04JUN90

T6642EJ -UN-18OCT88

SERVICE MACHINES SAFELY

Tie long hair behind your head. Do not wear a necktie, scarf, loose clothing, or necklace when you work near machine tools or moving parts. If these items were to get caught, severe injury could result.

Remove rings and other jewelry to prevent electrical shorts and entanglement in moving parts.

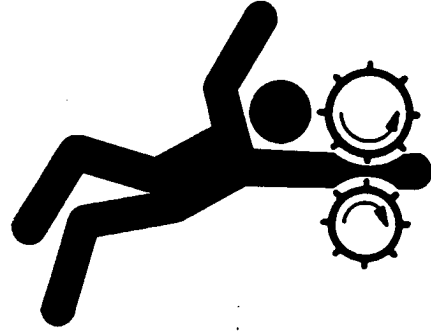

DX, LOOSE -19-04JUN90

1010
-UN-23AUG88
TS228

WORK IN VENTILATED AREA

Engine exhaust fumes can cause sickness or death. If it is necessary to run an engine in an enclosed area, remove the exhaust fumes from the area with an exhaust pipe extension.

If you do not have an exhaust pipe extension, open the doors and get outside air into the area.



DX, AIR -19-04JUN90

-UN-23AUG88
TS220

ILLUMINATE WORK AREA SAFELY

Illuminate your work area adequately but safely. Use a portable safety light for working inside or under the machine. Make sure the bulb is enclosed by a wire cage. The hot filament of an accidentally broken bulb can ignite spilled fuel or oil.

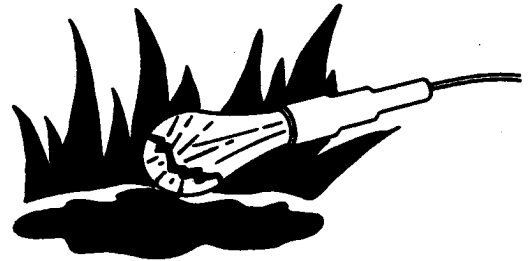

DX, LIGHT -19-04JUN90

-UN-23AUG88
TS223

REPLACE SAFETY SIGNS

Replace missing or damaged safety signs. See the machine operator's manual for correct safety sign placement.

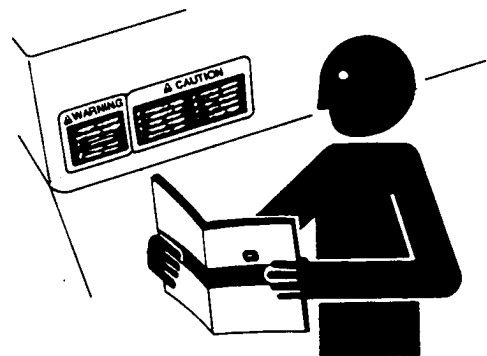

DX, SIGNS1 -19-04JUN90

-UN-23AUG88
TS201

USE PROPER LIFTING EQUIPMENT

Lifting heavy components incorrectly can cause severe injury or machine damage.

Follow recommended procedure for removal and installation of components in the manual.

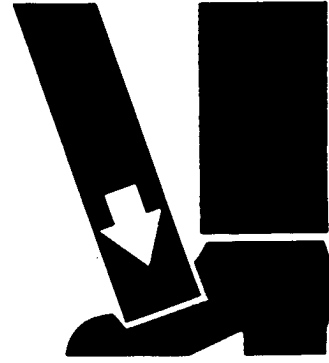

DX,LIFT -19-04JUN90

TS226 -UN-23AUG88

SERVICE TIRES SAFELY

Explosive separation of a tire and rim parts can cause serious injury or death.

Do not attempt to mount a tire unless you have the proper equipment and experience to perform the job.

Always maintain the correct tire pressure. Do not inflate the tires above the recommended pressure. Never weld or heat a wheel and tire assembly. The heat can cause an increase in air pressure resulting in a tire explosion. Welding can structurally weaken or deform the wheel.

When inflating tires, use a clip-on chuck and extension hose long enough to allow you to stand to one side and NOT in front of or over the tire assembly. Use a safety cage if available.

Check wheels for low pressure, cuts, bubbles, damaged rims or missing lug bolts and nuts.



DX,TIRECP -19-24AUG90

TS952 -UN-12APR90

10
05
6

REMOVE PAINT BEFORE WELDING OR HEATING

Avoid potentially toxic fumes and dust.

Hazardous fumes can be generated when paint is heated by welding, soldering, or using a torch.

Do all work outside or in a well ventilated area. Dispose of paint and solvent properly.

Remove paint before welding or heating:

- If you sand or grind paint, avoid breathing the dust. Wear an approved respirator.
- If you use solvent or paint stripper, remove stripper with soap and water before welding. Remove solvent or paint stripper containers and other flammable material from area. Allow fumes to disperse at least 15 minutes before welding or heating.

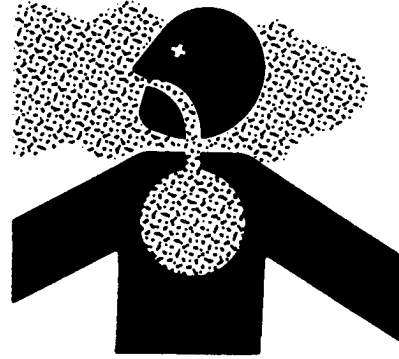

DX,PAINT -19-04JUN90

10
05
7
-UN-23AUG88
TS220

USE PROPER TOOLS

Use tools appropriate to the work. Makeshift tools and procedures can create safety hazards.

Use power tools only to loosen threaded parts and fasteners.

For loosening and tightening hardware, use the correct size tools. DO NOT use U.S. measurement tools on metric fasteners. Avoid bodily injury caused by slipping wrenches.

Use only service parts meeting John Deere specifications.



DX,REPAIR -19-04JUN90

-UN-08NOV89
TS779

DISPOSE OF FLUIDS PROPERLY

Improperly disposing of fluids can harm the environment and ecology. Before draining any fluids, find out the proper way to dispose of waste from your local environmental agency.

Use proper containers when draining fluids. Do not use food or beverage containers that may mislead someone into drinking from them.

DO NOT pour oil into the ground, down a drain, or into a stream, pond, or lake. Observe relevant environmental protection regulations when disposing of oil, fuel, coolant, brake fluid, filters, batteries, and other harmful waste.

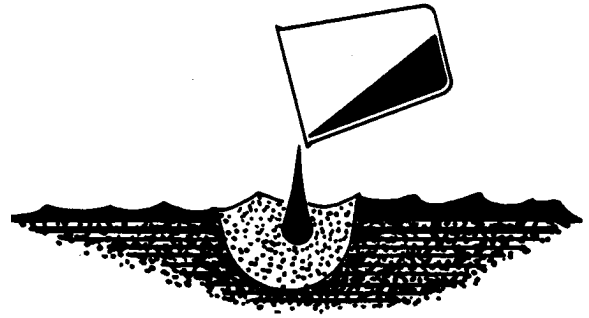

DX,DRAIN -19-05JUN90

TS222 -UN-23AUG88

LIVE WITH SAFETY

Before returning machine to customer, make sure machine is functioning properly, especially the safety systems. Install all guards and shields.



DX,LIVE -19-04JUN90

TS231 -19-07OCT88

POWER UNIT SPECIFICATIONS

	12.5 HP	14 HP	17 HP
ENGINE			
Make	John Deere "K" Series	John Deere "K" Series	John Deere "K" Series
Type	OHV	OHV	OHV
Model	FC400-AS11, AS05 and FC401V-BS05	FC420V-AS11, DS11 and ES11	FC540V-AS11, DS11 and ES11
Horsepower	9.3 kW (12.5 hp)	10.4 kW (14 hp)	12.6 kW (17 hp)
Number of Cylinders	1	1	1
Displacement	404 cm ³ (24.6 cu in.)	423 cm ³ (25.8 cu in.)	535 cm ³ (32.6 cu in.)
Bore and Stroke	87 x 68 mm (3.50 x 2.60 in.)	89 x 68 mm (3.50 x 2.68 in.)	89 x 86 mm (3.50 x 3.38 in.)
Fast Idle	3350 rpm	3350 rpm	3350 rpm
Slow Idle	1550 rpm	1550 rpm	1550 rpm
Starting System	Recoil Electric-optional	Recoil Electric-optional	Electric only
Lubrication	Pressurized	Pressurized	Pressurized
Cooling System	Forced Air	Forced Air	Forced Air
Air Cleaner	Dry 2 Stage Replaceable	Dry 2 Stage Replaceable	Dry 2 Stage Replaceable
Engine Shutoff	Key Switch	Key Switch	Key Switch
ELECTRICAL SYSTEM			
Type	12 Volt	12 Volt	12 Volt
Battery Size	160 Cold Cranking Amps at -18°C (0°F)	160 Cold Cranking Amps at -18°C (0°F)	160 Cold Cranking Amps at -18°C (0°F)
Stator	13 Amp	13 Amp	15 Amp
FUEL SYSTEM			
Type	Carburetor	Carburetor	Carburetor
Fuel Delivery	Fuel Pump	Fuel Pump	Fuel Pump
DRIVE TRAIN			
Type	Gear Transaxle	Gear Transaxle	Gear Transaxle
Number of Speeds	5 forward, 1 reverse	5 forward, 1 reverse	5 forward, 1 reverse
Travel Speeds at Full Engine RPM			
Forward			
1st Gear	2.6 km/h (1.6 mph)	2.6 km/h (1.6 mph)	2.6 km/h (1.6 mph)
2nd Gear	4.1 km/h (2.5 mph)	4.1 km/h (2.5 mph)	4.1 km/h (2.5 mph)
3rd Gear	6.1 km/h (3.8 mph)	6.1 km/h (3.8 mph)	6.1 km/h (3.8 mph)
4th Gear	7.8 km/h (4.8 mph)	7.8 km/h (4.8 mph)	7.8 km/h (4.8 mph)
5th Gear	9.5 km/h (5.9 mph)	9.5 km/h (5.9 mph)	9.5 km/h (5.9 mph)
Reverse	1.2 km/h (0.75 mph)	1.2 km/h (0.75 mph)	1.2 km/h (0.75 mph)
Brakes	Wet Disk	Wet Disk	Wet Disk
Park Brake	Clutch Interlock	Clutch Interlock	Clutch Interlock
Steering	Turn/Brake Lever and Linkage	Turn/Brake Lever and Linkage	Turn/Brake Lever and Linkage
PTO Clutch	Engine-mounted, electric	Engine-mounted, electric	Engine-mounted, electric
Clutch	Dual Lever, V-belt	Dual Lever, V-belt	Dual Lever, V-belt

Continued on next page

General Specifications/Specifications

10
10
2

14 HP

17 HP

CAPACITIES

Fuel Tank	19 L (5 U.S. gal)	19 L (5 U.S. gal)
Engine Crankcase with Filter	1.6 L (3.4 U.S. pt)	1.9 L (4.0 U.S. pt)
Transaxle	2.3 L (4.9 U.S. pt)	2.3 L (4.9 U.S. pt)

TIRES

Standard Equipment	13 x 6.50—6	13 x 6.50—6
--------------------	-------------	-------------

SHIPPING WEIGHT

Power Unit only	152 kg (334 lbs)	166 kg (365 lbs)
with 48 Inch Deck	258 kg (567 lbs)	272 kg (598 lbs)
with 54 Inch Deck	262 kg (577 lbs)	276 kg (608 lbs)

(Specifications and design subject to change without notice.)

MX,1010FP,A2 -19-05FEB91

MOWER DECK SPECIFICATIONS

48 Inch Deck

54 Inch Deck

Deck Material	11 gauge (3 mm) steel one-piece stamped	11 gauge (3 mm) steel one-piece stamped
Blades	3	3
Blade Length	42 cm (16.6 in.)	47 cm (18.6 in.)
Blade Drive	V-belt with self-adjusting Idler	V-belt with self-adjusting Idler
Cutting Height	19—102 mm (0.750—4 in.)	19—102 mm (0.750—4 in.)
Shipping Weight	106 kg (233 lbs)	110 kg (243 lbs)

(Specifications and design subject to change without notice.)

MX,1010FP,A3 -19-18FEB91

MACHINE REPAIR SPECIFICATIONS

SECTION 20-ENGINE REPAIR

Item	Measurement	Specification
For all repair specifications-Use CTM5		
Engine-to-Frame Cap Screw	Torque	16 N•m (144 lb-in.)
SECTION 30-FUEL AND AIR REPAIR		
For all carburetor repair specifications-Use CTM5		
SECTION 40-ELECTRICAL SYSTEM		
For all starter and engine ignition and charging system repair-Use CTM5		
Transaxle Neutral Start Switch-to-Case	Torque	10 N•m (88 lb-in.)
Electric PTO Clutch-to-Engine Crankshaft	Torque	56 N•m (45 lb-ft)
SECTION 50-POWER TRAIN REPAIR		
Axle/Shift Shaft Assembly --Miscellaneous Washers	Minimum Thickness	1.7 mm (0.067 in.)
	Minimum Thickness	2.2 mm (0.087 in.)
Reduction Shaft Assembly --Grooved Washer	Minimum Thickness	1.7 mm (0.067 in.)
Brake Assembly--Friction Disks	Minimum Thickness	1.9 mm (0.075 in.)
--Friction Plates	Minimum Thickness	1.25 mm (0.049 in.)
Clutch Shaft Assembly		
--Plate	Minimum Thickness	4.3 mm (0.169 in.)
--Clutch Disk	Minimum Thickness	1.9 mm (0.075 in.)
--Eight Plates	Minimum Thickness	0.9 mm (0.035 in.)
--Plate	Minimum Thickness	3.0 mm (0.118 in.)
--Clutch Springs (Single Spring Style)	Minimum Free Length	30.3 mm (1.193 in.)
	Compressed Length	21 mm (0.827 in.) at 173-194 N (39-44 lb force)

Continued on next page

0
5
2

SECTION 50-POWER TRAIN REPAIR-CONTINUED























Item	Measurement	Specification
Idler Shaft Assembly-to-Case Half Cap Screw	Torque (New) Torque (Used)	9 N•m (82 lb-in.) 6 N•m (56 lb-in.)
Snap Ring-to-Clutch Assembly	Clearance	1-5 mm (0.039-0.197 in.)
Top Edge of Cam Plate Housing -to-Top Edge of Clutch Housing	Clearance	3 -5.5 mm (0.118-0.217 in.)
Input Shaft-to-Reduction Shaft	Backlash	0.1-0.3 mm (0.004-0.012 in.)
Shift Shaft Key Spring	Minimum Force	13.7 N (3.1 lb force)
Input Shaft Assembly-to-Case Half Cap Screw	Torque (New) Torque (Used)	29 N•m (22 lb-ft) 25 N•m (18 lb-ft)
Transaxle Case Half Cap Screw	Torque	16 N•m (144 lb-in.)
Neutral Start Switch-to-Case	Torque	10 N•m (88 lb-in.)
Shift Arm Nut	Torque	45-50 N•m (33-37 lb-ft)
Brake Spring	Free Length	136 mm (5.3 in.)
	Minimum Test Length at 141 N (32 lb. force)	90 mm (3.5 in.)
SECTION 80-MISCELLANEOUS REPAIR		
Mower Blade Cap Screw	Torque	68 N•m (50 lb-ft)
Spindle Nut	Torque	26 N•m (19 lb-ft)
Sheave-to-Spindle Nut	Torque	163 N•m (120 lb-ft)

TUNE-UP SPECIFICATIONS

Spark plug gap	0.64 mm (0.025 in.)
Spark plug torque	20 N·m (177 lb-in.)
Slow idle setting	
Throttle control lever slow idle stop screw setting	1500 ± 50 rpm
Carburetor slow idle stop screw setting	1400 ± 50 rpm
Fast idle setting	3350 ± 100 rpm

MX,1015FP,A2 -19-18FEB91

METRIC FASTENER TORQUE VALUES

Property Class and Head Markings	4.8		8.8		9.8		10.9		12.9			
												
Property Class and Nut Markings	5		10		10		12					
												

TS1163

SIZE	Class 4.8				Class 8.8 or 9.8				Class 10.9				Class 12.9			
	Lubricated ^a		Dry ^a		Lubricated ^a		Dry ^a		Lubricated ^a		Dry ^a		Lubricated ^a		Dry ^a	
	N•m	lb-ft	N•m	lb-ft	N•m	lb-ft	N•m	lb-ft	N•m	lb-ft	N•m	lb-ft	N•m	lb-ft	N•m	lb-ft
M6	4.8	3.5	6	4.5	9	6.5	11	8.5	13	9.5	17	12	15	11.5	19	14.5
M8	12	8.5	15	11	22	16	28	20	32	24	40	30	37	28	47	35
M10	23	17	29	21	43	32	55	40	63	47	80	60	75	55	95	70
M12	40	29	50	37	75	55	95	70	110	80	140	105	130	95	165	120
M14	63	47	80	60	120	88	150	110	175	130	225	165	205	150	260	109
M16	100	73	125	92	190	140	240	175	275	200	350	225	320	240	400	300
M18	135	100	175	125	260	195	330	250	375	275	475	350	440	325	560	410
M20	190	140	240	180	375	275	475	350	530	400	675	500	625	460	800	580
M22	260	190	330	250	510	375	650	475	725	540	925	675	850	625	1075	800
M24	330	250	425	310	650	475	825	600	925	675	1150	850	1075	800	1350	1000
M27	490	360	625	450	950	700	1200	875	1350	1000	1700	1250	1600	1150	2000	1500
M30	675	490	850	625	1300	950	1650	1200	1850	1350	2300	1700	2150	1600	2700	2000
M33	900	675	1150	850	1750	1300	2200	1650	2500	1850	3150	2350	2900	2150	3700	2750
M36	1150	850	1450	1075	2250	1650	2850	2100	3200	2350	4050	3000	3750	2750	4750	3500

DO NOT use these hand torque values if a different torque value or tightening procedure is given for a specific application. Torque values listed are for general use only and include a ±10% variance factor. Check tightness of fasteners periodically. DO NOT use air powered wrenches.

Shear bolts are designed to fail under predetermined loads. Always replace shear bolts with identical grade.

Fasteners should be replaced with the same class. Make sure fastener threads are clean and that you properly start thread engagement. This will prevent them from failing when tightening.

When bolt and nut combination fasteners are used, torque values should be applied to the **NUT** instead of the bolt head.

Tighten toothed or serrated-type lock nuts to the full torque value.

^a "Lubricated" means coated with a lubricant such as engine oil, or fasteners with phosphate and oil coatings. "Dry" means plain or zinc plated (yellow dichromate - Specification JDS117) without any lubrication.

Reference: JDS—G200.











**Thank you very much for
your reading. Please Click
Here. Then Get COMPLETE
MANUAL. NO WAITING**



NOTE:

**If there is no response to
click on the link above,
please download the PDF
document first and then
click on it.**

INCH FASTENER TORQUE VALUES

SAE Grade and Head Markings	1 or 2 ^b No Marks 	5  5.1  5.2 	8  8.2 
	2 No Marks 	5  	8  

TS1162

SIZE	Grade 1		Grade 2 ^b		Grade 5, 5.1 or 5.2		Grade 8 or 8.2	
	Lubricated ^a		Dry ^a		Lubricated ^a		Dry ^a	
	N•m	lb-ft	N•m	lb-ft	N•m	lb-ft	N•m	lb-ft
1/4	3.7	2.8	4.7	3.5	6	4.5	7.5	5.5
5/16	7.7	5.5	10	7	12	9	15	11
3/8	14	10	17	13	22	16	27	20
7/16	22	16	28	20	35	26	44	32
1/2	33	25	42	31	53	39	67	50
9/16	48	36	60	45	75	56	95	70
5/8	67	50	85	62	105	78	135	100
3/4	120	87	150	110	190	140	240	175
7/8	190	140	240	175	190	140	240	175
1	290	210	360	270	290	210	360	270
1-1/8	470	300	510	375	470	300	510	375
1-1/4	570	425	725	530	570	425	725	530
1-3/8	750	550	950	700	750	550	950	700
1-1/2	1000	725	1250	925	990	725	1250	930

DO NOT use these hand torque values if a different torque value or tightening procedure is given for a specific application. Torque values listed are for general use only and include a ±10% variance factor. Check tightness of fasteners periodically. DO NOT use air powered wrenches.

Shear bolts are designed to fail under predetermined loads. Always replace shear bolts with identical grade.

Fasteners should be replaced with the same grade. Make sure fastener threads are clean and that you properly start thread engagement. This will prevent them from failing when tightening.

When bolt and nut combination fasteners are used, torque values should be applied to the **NUT** instead of the bolt head.









Tighten toothed or serrated-type lock nuts to the full torque value.

^a "Lubricated" means coated with a lubricant such as engine oil, or fasteners with phosphate and oil coatings. "Dry" means plain or zinc plated (yellow dichromate - Specification JDS117) without any lubrication.

^b "Grade 2" applies for hex cap screws (not hex bolts) up to 152 mm (6-in.) long. "Grade 1" applies for hex cap screws over 152 mm (6-in.) long, and for all other types of bolts and screws of any length.

Reference: JDS—G200.

INCH CAP SCREW TORQUE VALUES

SAE Grade	Head Markings	SAE Grade	Nut Markings	SAE Grade	Head Markings	SAE Grade	SAE Grade	Nut Markings	SAE Grade
SAE GRADE 1 SAE GRADE 2	 No Mark	2	 No Mark	SAE GRADE 5 SAE GRADE 5.1 SAE GRADE 5.2	  	5	Nut Markings	SAE GRADE 8 SAE GRADE 8.2	 
									8 Nut Markings 

DIA.	WRENCH SIZE	SAE GRADE 1		*SAE GRADE 2		SAE GRADE 5		SAE GRADE 8	
		OIL	DRY	OIL	DRY	OIL	DRY	OIL	DRY
		N•m(lb-in)	N•m(lb-in)	N•m(lb-in)	N•m(lb-in)	N•m(lb-in)	N•m(lb-in)	N•m(lb-in)	N•m(lb-in)
#6 #8		0.5(4.5) 0.9(8)	0.7(6) 1.2(11)			1.4(12) 2.4(21)	1.7(15) 3.2(28)		
#10 #12		1.4(12) 2(19)	1.8(16) 2.8(25)			3.4(30) 5.4(48)	4.6(41) 7.3(65)		
		N•m(lb-ft)	N•m(lb-ft)	N•m(lb-ft)	N•m(lb-ft)	N•m(lb-ft)	N•m(lb-ft)	N•m(lb-ft)	N•m(lb-ft)
1/4 5/16	7/16 1/2	3.5(2.5) 7(5)	4(3) 9(6.5)	5(4) 10(7.5)	7(5) 14(10)	8(6) 16(12)	11(8) 23(17)	12(8.5) 24(18)	16(12) 33(24)
3/8 7/16	9/16 5/8	12(8.5) 19(14)	16(12) 26(19)	19(14) 30(22)	24(18) 41(30)	30(22) 47(35)	41(30) 68(50)	41(30) 68(50)	54(40) 95(70)
1/2 9/16	3/4 13/16	24(21) 41(30)	41(30) 54(40)	47(35) 68(50)	61(45) 88(65)	75(55) 108(80)	102(75) 142(105)	102(75) 149(110)	142(105) 203(150)
5/8 3/4	15/16 1-1/8	54(40) 102(75)	75(55) 136(100)	88(65) 163(120)	122(90) 217(160)	149(110) 258(190)	197(145) 353(260)	203(150) 366(270)	278(205) 495(365)
7/8 1	1-5/16 1-1/2	163(120) 244(180)	244(165) 332(245)	163(120) 244(180)	224(165) 332(245)	414(305) 624(460)	563(415) 848(625)	590(435) 881(650)	800(590) 1193(880)
1-1/8 1-1/4	1-11/16 1-7/8	346(255) 488(360)	468(345) 664(490)	346(255) 488(360)	468(345) 665(490)	780(575) 1098(810)	1058(780) 1492(1100)	1248(920) 1763(1300)	1695(1250) 2393(1765)
1-3/8 1-1/2	2-1/16 2-1/4	637(470) 848(625)	868(640) 1153(850)	637(470) 848(625)	868(640) 1153(850)	1438(1061) 1912(1410)	1953(1440) 2590(1910)	2312(1705) 3065(2260)	3140(2315) 4163(3070)

DO NOT use these values if a different torque value or tightening procedure is listed for a specific application. Torque values listed are for general use only. Check tightness of cap screws periodically.

Shear bolts are designed to fail under predetermined loads. Always replace shear bolts with identical grade.

Fasteners should be replaced with the same or higher grade. If higher grade fasteners are used, these should only be tightened to the strength of the original.

*For SAE Grade 2 fasteners 152 mm (6 in.) or less in length, use torque values for SAE Grade 2. For fasteners longer than 152 mm (6 in.), use SAE Grade 1 torque values.

Make sure fastener threads are clean and you properly start thread engagement. This will prevent them from failing when tightening.

Tighten plastic insert or crimped steel-type lock nuts to approximately 50 percent of amount shown in chart. Tighten toothed or serrated-type lock nuts to full torque value.

GASOLINE 4-CYCLE ENGINES - NORTH AMERICA

CAUTION

Gasoline is **HIGHLY FLAMMABLE**, handle it with care.

DO NOT refuel machine while:

- indoors, always fill gas tank outdoors;
- machine is near an open flame or sparks;
- engine is running, **STOP** engine;
- engine is hot, allow it to cool sufficiently first;
- smoking.

Help prevent fires:

- fill gas tank to bottom of filler neck only;
- be sure fill cap is tight after fueling;
- clean up any gas spills **IMMEDIATELY**;
- keep machine clean and in good repair—free of excess grease, oil, debris, and faulty or damaged parts;
- any storage of machines with gas left in tank should be in an area that is well ventilated to prevent possible igniting of fumes by an open flame or spark, this includes any appliance with a pilot light.

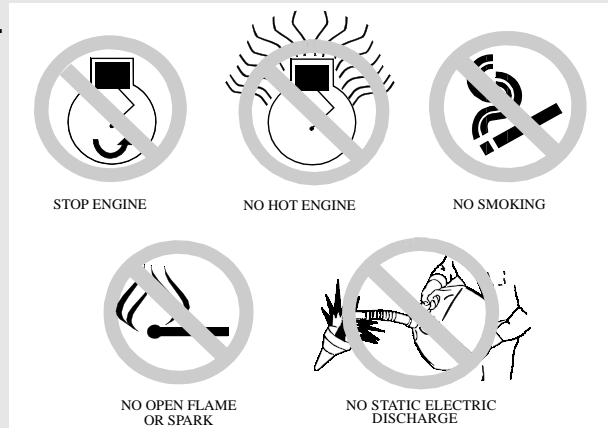

To prevent fire or explosion caused by **STATIC ELECTRIC DISCHARGE** during fueling:

- **ONLY** use a clean, approved **POLYETHYLENE PLASTIC** fuel container and funnel **WITHOUT** any metal screen or filter.

To avoid engine damage:

- **DO NOT** mix oil with gasoline;
- **ONLY** use clean, fresh unleaded gasoline with an octane rating (anti-knock index) of 87 or higher;
- fill gas tank at the end of each day's operation to help prevent condensation from forming inside a partially filled tank;
- keep up with specified service intervals.

Use of alternative oxygenated, gasohol blended, unleaded gasoline is acceptable as long as:

- the ethyl or grain alcohol blends **DO NOT** exceed 10% by volume or
- methyl tertiary butyl ether (MTBE) blends **DO NOT** exceed 15% by volume.

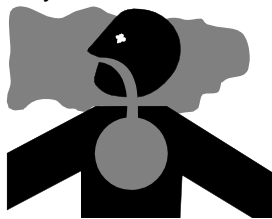

IMPORTANT: DO NOT use **METHANOL** gasolines because **METHANOL** is harmful to the environment and to your health.

WARNING

California Proposition 65 Warning: Gasoline engine exhaust from this product contains chemicals known to the State of California to cause cancer, birth defects, or other reproductive harm.

GASOLINE STORAGE

IMPORTANT: Keep all dirt, scale, water or other foreign material out of gasoline.

Keep gasoline stored in a safe, protected area. Storage of gasoline in a clean, properly marked ("**UNLEADED GASOLINE**") **POLYETHYLENE PLASTIC** container **WITHOUT** any metal screen or filter is recommended. **DO NOT** use de-icers to attempt to remove water from gasoline or depend on fuel filters to remove water from gasoline. Use a water separator installed in the storage tank outlet. **BE SURE** to properly discard unstable or contaminated gasoline. When storing unit or gasoline, it is recommended that you add **John Deere Gasoline Conditioner and Stabilizer (TY15977)** or an equivalent to the gasoline. **BE SURE** to follow directions on container and to properly discard empty container.