

Workshop Service Manual

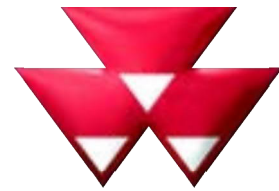

MASSEY FERGUSON

Draper Header

5300

Draper Header

1 General	1-1
1.1 General information	1-3
1.1.1 Introduction to this service manual	1-3
1.1.2 Units of measurement	1-3
1.1.3 Table of contents	1-3
1.1.4 Page numbers	1-3
1.1.5 Intended use	1-3
1.1.6 Proper disposal of waste	1-3
1.2 Safety	1-5
1.2.1 Safety alert symbol	1-5
1.2.2 Safety messages	1-5
1.2.3 Informational messages	1-5
1.2.4 Safety signs	1-5
1.2.5 A word to the technician	1-6
1.2.6 The service manual	1-7
1.2.7 Operation	1-7
1.2.7.1 Prepare for operation	1-7
1.2.7.2 General information	1-8
1.2.7.3 Personal protective equipment	1-9
1.2.7.4 Seat instructions	1-9
1.2.7.5 Shield and guards	1-9
1.2.7.6 Exhaust warning	1-10
1.2.7.7 Flying debris	1-10
1.2.7.8 Handrails	1-11
1.2.7.9 Agricultural chemicals	1-11
1.2.8 Travel on public roads	1-11
1.2.9 Maintenance	1-12
1.2.9.1 General maintenance information	1-12
1.2.9.2 Fire prevention and first aid	1-14
1.2.9.3 High pressure leaks	1-15
1.2.9.4 Tire safety	1-16
1.2.9.5 Replacement parts	1-16
1.3 Cylinder stops	1-17
1.3.1 Engaging the stop for the reel lift cylinder	1-17
1.3.2 Disengaging the stop for the reel lift cylinder	1-17
1.4 Specifications	1-18
1.4.1 Dimensions and weights	1-18
1.4.2 Header specifications	1-18
1.4.3 Sickle specifications	1-18
1.4.4 Reel specifications	1-19
1.4.5 Draper specifications	1-19
1.4.6 Tire specifications	1-19
1.4.7 Lubrication specifications	1-19
1.5 Bolt torque values	1-20
1.6 Machine identification	1-22
1.6.1 Serial number plate	1-22
1.6.2 Serial number description	1-22
1.7 Draper header description	1-23
1.7.1 Header description	1-23
1.7.2 Draper description	1-23
1.7.3 Reel description	1-23

1.7.4	Opening the end shield	1-24
1.7.5	Closing the end shield	1-24
1.8	Bearing replacement	1-25
1.8.1	Removing an eccentric locking collar	1-25
1.8.2	Installing an eccentric locking collar	1-25
2	Draper Assemblies	2-1
2.1	Draper troubleshooting	2-3
2.2	Introduction	2-4
2.2.1	Protecting the drapers	2-4
2.3	Draper tension	2-5
2.3.1	Increasing the draper tension	2-5
2.3.2	Decreasing the draper tension	2-5
2.3.3	Adjusting the draper tension pointer	2-5
2.4	Draper removal and installation	2-7
2.4.1	Removing a draper	2-7
2.4.2	Installing a draper	2-7
2.5	Alignment and tracking	2-9
2.5.1	Aligning the rollers	2-9
2.5.2	Draper tracking	2-10
2.6	Idler roller	2-11
2.6.1	Disassembling the draper idler roller	2-11
2.6.2	Assembling the draper idler roller	2-12
2.7	Drive roller	2-14
2.7.1	Disassembling the draper drive roller	2-14
2.7.2	Assembling the draper drive roller	2-15
3	Cutterbar	3-1
3.1	Cutterbar troubleshooting	3-3
3.2	Sickle	3-5
3.2.1	General sickle maintenance	3-5
3.2.2	Replacing the sickle	3-5
3.2.3	Checking the sickle register	3-5
3.2.4	Adjusting the sickle register	3-6
3.2.5	Standard sickle and guards	3-7
3.2.5.1	Replacing sickle sections	3-7
3.2.5.2	Replacing sickle guards	3-7
3.2.5.3	Adjusting the sickle holddowns	3-8
3.2.6	Schumacher (SCH) sickle and guards	3-9
3.2.6.1	Replacing sickle sections	3-9
3.2.6.2	Replacing sickle guards	3-9
3.3	Sickle drive gearbox	3-11
3.3.1	Checking the sickle vertical adjustment	3-11
3.3.2	Checking the sickle fore and aft adjustment	3-12
3.3.3	Removing the sickle drive gearbox	3-13
3.3.4	Installing the sickle drive gearbox	3-13
3.3.5	Disassembling the sickle drive gearbox	3-14
3.3.6	Assembling the sickle drive gearbox	3-20
4	Hydraulic system	4-1
4.1	Changing the hydraulic oil filter	4-3
4.2	Hydraulic testing	4-4
4.2.1	Testing the draper drive system pressure	4-4
4.2.2	Testing the reel drive system pressure	4-5
4.2.3	Testing the sickle drive system pressure	4-6

4.2.4	Testing the charge pressure for the header drive pump	4-8
4.3	Sickle drive motor	4-10
4.3.1	Sickle drive motor specifications	4-10
4.3.2	Removing the sickle drive motor	4-10
4.3.3	Installing the sickle drive motor	4-12
4.4	Reel drive motor	4-15
4.4.1	Reel drive motor specifications	4-15
4.4.2	Removing the reel drive motor	4-15
4.4.3	Installing the reel drive motor	4-16
4.5	Draper drive motor	4-18
4.5.1	Draper drive motor specifications	4-18
4.5.2	Removing the draper drive motor	4-18
4.5.3	Installing the draper drive motor	4-19
4.6	Sickle drive relief valve	4-21
4.6.1	Sickle drive relief valve	4-21
4.6.2	Removing the sickle drive relief valve	4-21
4.6.3	Installing the sickle drive relief valve	4-22
4.6.4	Disassembling the relief valve	4-23
4.6.5	Inspecting the relief valve housing	4-23
4.6.6	Assembling the relief valve	4-23
4.7	Reel drive control valve	4-24
4.7.1	Reel drive control valve	4-24
4.7.2	Removing the reel drive control valve	4-25
4.7.3	Installing the reel drive control valve	4-26
4.7.4	Inspecting the control valve housing	4-27
4.8	Draper drive control valve	4-28
4.8.1	Draper drive control valve	4-28
4.8.2	Removing the draper drive control valve	4-30
4.8.3	Installing the draper drive control valve	4-31
4.8.4	Inspecting the control valve housing	4-32
4.9	Control valve cartridge	4-33
4.9.1	Removing the cartridge	4-33
4.9.2	Inspecting the cartridge	4-33
4.9.3	Installing the cartridge	4-33
4.9.4	Testing the solenoid valve coil	4-34
4.10	Reel lift master cylinder	4-36
4.10.1	Removing the reel lift master cylinder	4-36
4.10.2	Installing the reel lift master cylinder	4-36
4.10.3	Reel lift master cylinder components	4-37
4.10.4	Disassembling the reel lift master cylinder	4-38
4.10.5	Inspecting the cylinder assembly	4-38
4.10.6	Assembling the reel lift master cylinder	4-39
4.11	Reel lift slave cylinder	4-40
4.11.1	Removing the reel lift slave cylinder	4-40
4.11.2	Installing the reel lift slave cylinder	4-40
4.11.3	Reel lift slave cylinder components	4-41
4.11.4	Disassembling the reel lift slave cylinder	4-41
4.11.5	Inspecting the cylinder assembly	4-42
4.11.6	Assembling the reel lift slave cylinder	4-42
4.12	Reel lift cylinder phase	4-43
4.12.1	Putting the reel lift cylinders into phase	4-43
4.12.2	Bleeding the reel lift cylinders	4-43
4.13	Reel leveling	4-44
4.13.1	Leveling the reel	4-44
4.14	Draper shift	4-45
4.14.1	Adjusting the draper opening - double swath header	4-45

4.14.2	Draper shift motor specifications	4-45
4.14.3	Removing the draper shift motor	4-45
4.14.4	Installing the draper shift motor	4-47
4.15	Eaton 2000 series motor	4-49
4.15.1	Exploded view of the Eaton 2000 series motor	4-49
4.15.2	Disassembling the Eaton 2000 series motor	4-49
4.15.3	Inspecting the Eaton 2000 series motor	4-53
4.15.4	Assembling the Eaton 2000 series motor	4-54
4.16	Eaton H series motor	4-59
4.16.1	Exploded view of the Eaton H series motor	4-59
4.16.2	Disassembling the Eaton H series motor	4-59
4.16.3	Inspecting the Eaton H series motor	4-63
4.16.4	Assembling the Eaton H series motor	4-63
5	Electrical system	5-1
5.1	Basic electrical troubleshooting	5-3
5.1.1	Basic troubleshooting procedures	5-3
5.1.2	Tools	5-4
5.1.3	Continuity check	5-4
5.1.4	Voltage check	5-5
5.2	Connectors	5-6
5.2.1	Checking a connector	5-6
5.2.2	Terminal numbers	5-6
5.2.3	Dielectric grease	5-7
5.2.4	Pins and sockets	5-7
5.2.5	Replacing a Packard connector	5-8
5.2.6	Replacing an AMP connector	5-8
5.2.7	Replacing a Power Cord connector	5-9
5.2.8	Replacing a Deutsch connector	5-9
5.2.9	Tractor to header connector	5-10
5.3	Reel speed sensor	5-12
5.3.1	Adjusting the reel speed sensor	5-12
5.4	Header speed sensor	5-14
5.4.1	Header speed sensor	5-14
5.5	Header speed jumper harness	5-15
5.6	VMM	5-16
5.6.1	VMM inputs and outputs	5-16
5.6.2	Draper header VMM	5-16
6	Reels	6-1
6.1	Reel description	0
6.2	Reel troubleshooting	6-3
6.3	Reel drive gearcase	6-4
6.3.1	Checking the reel drive gearcase for lubricant	6-4
6.3.2	Removing the reel drive gearcase	6-4
6.3.3	Installing the reel drive gearcase	6-5
6.3.4	Disassembling the reel drive gearcase	6-7
6.3.5	Inspecting the reel drive gearcase	6-9
6.3.6	Assembling the reel drive gearcase	6-9
6.4	Reel	6-12
6.4.1	During lubrication	6-12
6.4.2	Inspecting the reel	6-12
6.4.3	Removing the reel	6-13
6.4.4	Installing the reel	6-13
6.4.5	Tine pitch	6-14
6.4.6	Adjusting the tine pitch	6-14

6.4.7	Replacing a reel tine	6-14
6.4.8	Removing the tine tube	6-15
6.4.9	Installing the tine tube	6-16
7	Accessories	7-1
7.1	Cross auger kit	7-3
7.1.1	Cross auger motor specifications	7-3
7.1.2	Removing the cross auger motor	7-3
7.1.3	Installing the cross auger motor	7-4
7.2	Windrower tractor weights	7-5
8	Diagrams	8-1
8.1	How to read wiring schematics	8-3
8.1.1	Diagram numbers	8-3
8.1.2	Location grids	8-3
8.1.3	Wire breaks	8-4
8.2	Diagram symbols and abbreviations	8-6
8.2.1	Harness and connector identification	8-6
8.2.2	Splices	8-6
8.2.3	CAN signal	8-7
8.2.4	Optional components	8-7
8.2.5	Device identification numbers	8-7
8.3	Electrical diagrams	8-9
8.3.1	Harness abbreviations	8-9
8.3.2	Wire colors	8-9
8.3.3	CAN 4 network (header CAN)	8-11
8.3.4	Connector views	8-12
8.3.5	Turn and hazard lamps	8-13
8.3.6	Turn and hazard lamps with transport kit	8-14
8.3.7	Main electrical diagram	8-15
8.3.8	Reel fore/aft diagram	8-16
8.4	Circuit table	8-17
8.5	Connector table	8-23
8.6	Hydraulic schematics	8-28
8.6.1	Center delivery hydraulic schematic	8-28
8.6.2	Double swath hydraulic schematic	8-30
9	Index	Index-1

1. General

1.1 General information	1-3
1.1.1 Introduction to this service manual	1-3
1.1.2 Units of measurement	1-3
1.1.3 Table of contents	1-3
1.1.4 Page numbers	1-3
1.1.5 Intended use	1-3
1.1.6 Proper disposal of waste	1-3
1.2 Safety	1-5
1.2.1 Safety alert symbol	1-5
1.2.2 Safety messages	1-5
1.2.3 Informational messages	1-5
1.2.4 Safety signs	1-5
1.2.5 A word to the technician	1-6
1.2.6 The service manual	1-7
1.2.7 Operation	1-7
1.2.7.1 Prepare for operation	1-7
1.2.7.2 General information	1-8
1.2.7.3 Personal protective equipment	1-9
1.2.7.4 Seat instructions	1-9
1.2.7.5 Shield and guards	1-9
1.2.7.6 Exhaust warning	1-10
1.2.7.7 Flying debris	1-10
1.2.7.8 Handrails	1-11
1.2.7.9 Agricultural chemicals	1-11
1.2.8 Travel on public roads	1-11
1.2.9 Maintenance	1-12
1.2.9.1 General maintenance information	1-12
1.2.9.2 Fire prevention and first aid	1-14
1.2.9.3 High pressure leaks	1-15
1.2.9.4 Tire safety	1-16
1.2.9.5 Replacement parts	1-16
1.3 Cylinder stops	1-17
1.3.1 Engaging the stop for the reel lift cylinder	1-17
1.3.2 Disengaging the stop for the reel lift cylinder	1-17
1.4 Specifications	1-18
1.4.1 Dimensions and weights	1-18
1.4.2 Header specifications	1-18
1.4.3 Sickle specifications	1-18
1.4.4 Reel specifications	1-19
1.4.5 Draper specifications	1-19
1.4.6 Tire specifications	1-19
1.4.7 Lubrication specifications	1-19
1.5 Bolt torque values	1-20
1.6 Machine identification	1-22
1.6.1 Serial number plate	1-22
1.6.2 Serial number description	1-22
1.7 Draper header description	1-23
1.7.1 Header description	1-23
1.7.2 Draper description	1-23
1.7.3 Reel description	1-23

1.7.4	Opening the end shield	1-24
1.7.5	Closing the end shield	1-24
1.8	Bearing replacement	1-25
1.8.1	Removing an eccentric locking collar	1-25
1.8.2	Installing an eccentric locking collar	1-25

1.1 General information

1.1.1 Introduction to this service manual

This service manual gives information from engineering tests, operating data, and the latest service techniques at the time of publication. Read this service manual carefully before doing any service on the machine.

The photos and illustrations used in this service manual were current at the time of publication. Production changes can cause machines to vary from the photos and the illustrations. The manufacturer reserves the right to redesign and change machines as necessary without notification.



WARNING:

Some pictures in this manual show the machine with shields or guards removed to permit for a better view of the subject of the picture. All shields and guards must be in position before operating the machine.

Machine movement when in normal use determines right-hand and left-hand.

1.1.2 Units of measurement

Measurements are given in metric units followed by the equivalent in US units. Hardware sizes are given in millimeters for metric hardware and inches for US hardware.

1.1.3 Table of contents

This manual has a table of contents at the front. The table of contents shows the divisions. The individual divisions also have a table of contents.

1.1.4 Page numbers

All pages have two numbers, such as 01-25. The first number shows the division. The second number shows the page in the division.

Page numbers occur on the lower right-hand or lower left-hand corner of each page.

1.1.5 Intended use

This machine is designed solely for use in customary agricultural operations.

Do not use this machine for any application or purpose other than those described in this manual. The manufacturer accepts no liability for damage or injury resulting from misuse of this machine.

Compliance with the conditions of operation, service and repair as specified by the manufacturer constitute essential elements for the intended use of this machine.

This machine should be operated, serviced and repaired only by qualified persons familiar with its characteristics and familiar with the relevant safety rules and procedures.

All generally recognized safety regulations and road traffic regulations must be obeyed at all times.

Any unauthorized modifications performed on this machine will relieve the manufacturer of all liability for any resulting damage or injury.

1.1.6 Proper disposal of waste

Improper disposal of waste can pollute the environment and ecology. A few examples of potentially harmful equipment waste can include, but not limited to, items such as oil, fuel, coolant, brake fluid, filters, battery chemicals, tires, etc.

Use leak proof containers when draining fluids. Do not use food or beverage containers to collect waste fluids, as food or beverage container(s) may mislead someone into drinking from them.

Do not pour or spill waste onto the ground, down a drain, or into any water source.

1. General

Air conditioning refrigerants escaping into the air can damage the Earth's atmosphere. Government regulations may require a certified air conditioning service center to recover and recycle used air conditioning refrigerants.

Inquire with local environmental or recycling center on the proper way to recycle or dispose waste.

1.2 Safety

1.2.1 Safety alert symbol

The safety alert symbol means Attention! Become Alert! Your Safety Is Involved!

Look for the safety alert symbol both in this manual and on safety signs on this machine. The safety alert symbol will direct your attention to information that involves your safety and the safety of others.



Fig. 1

1.2.2 Safety messages

The words DANGER, WARNING or CAUTION are used with the safety alert symbol. Learn to recognize these safety alerts and follow the recommended precautions and safety practices.



DANGER:
Indicates an imminently hazardous situation that, if not avoided, will result in DEATH OR VERY SERIOUS INJURY.



WARNING:
Indicates a potentially hazardous situation that, if not avoided, could result in DEATH OR SERIOUS INJURY.



CAUTION:
Indicates a potentially hazardous situation that, if not avoided, may result in MINOR INJURY.



Fig. 2

1.2.3 Informational messages

The words important and note are not related to personal safety, but are used to give additional information and tips for operating or servicing this equipment.

IMPORTANT: *Identifies special instructions or procedures which, if not strictly observed, could result in damage to or destruction of the machine, process, or its surroundings*

NOTE: *Identifies points of particular interest for more efficient and convenient repair or operation.*

1.2.4 Safety signs



WARNING:
Do not remove or obscure safety signs. Replace any safety signs that are not readable or are missing. Replacement signs are available from your dealer in the event of loss or damage. The actual location of the safety signs is illustrated at the end of this section.

Keep signs clean by wiping off regularly. Use a mild soap and water solution if necessary.

If parts have been replaced or a used machine has been purchased, make sure all safety signs are present and in the correct location and can be read. Illustrations of safety sign locations are located at the rear of this section.

Replace any safety signs that can not be read, are damaged, or are missing. Clean the machine surface thoroughly with a mild soap and water solution before replacing signs. Replacement safety signs are available from your dealer.

1.2.5 A word to the technician

Read and understand the safety section in this service manual before operating or servicing the machine. Read and understand the safety sections in the manuals for all attachments before operating or servicing attachments. The technician has the key to safety. Good safety practices protect everyone.

Study the safety information in this service manual. Make the safety information a working part of the safety program. The safety information in this service manual applies specifically to this type of machine. Always do all other usual and customary safe working precautions. Remember - The technician has the responsibility for safety. Good safety practices can prevent serious injury or death.

The safety section points out some basic safety situations that can occur during the operation and maintenance of the machine. The safety section also suggests possible ways to deal with these situations. The safety section does not replace safety practices in other parts of this service manual.

Practice good safety to help prevent injury or death.

Learn how to operate the machine and how to use the controls correctly.

Do not let other persons operate the machine without instruction and training.

Follow all safety precautions and instructions in the manuals and on safety signs affixed to the machine and all attachments.

Use only approved attachments and equipment.

Make sure the machine has the correct equipment needed by the local regulations.

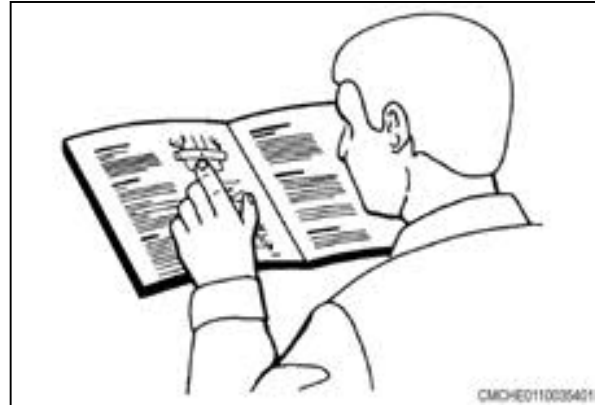

Fig. 3



WARNING:
An operator should not use alcohol or drugs which can affect their alertness or coordination. An operator on prescription or 'over the counter' drugs needs medical advice on whether or not they can properly operate machines. If any attachments used on this equipment have a separate Operator Manual, see that manual for other important safety information.

1.2.6 The service manual

Read the table of contents and basic layout. Become familiar with all parts of this service manual. This service manual gives the technician very important information.

Machine movement when in normal use determines right-hand and left-hand.

This manual covers general safety practices for this machine.

The photos, illustrations, and data used in this manual were current at the time of printing. Inline production changes can make machines vary from the information in the service manual. The manufacturer reserves the right to redesign and change the machine as necessary without notification.



WARNING:
In some of the illustrations and photos used in this manual, shields or guards may have been removed for clarity. Never operate the machine with any shields or guards removed. If the removal of shields or guards is necessary to make a repair, they must be replaced before operation.

1.2.7 Operation

1.2.7.1 Prepare for operation

Read and understand all operating instructions and precautions in this manual before operating or servicing the machine.

Make sure you know and understand the positions and operations of all controls. Make certain all controls are in neutral and the park brake is applied before starting the machine. Make sure the steering wheel is centered and locked.



WARNING:
Any time the engine is running and the park brake is disengaged, the machine will turn if the steering wheel is moved even though the travel control lever is in neutral.

Make certain all people are well away from your area of work before starting and operating the machine. Check and learn all controls in an area clear of people and obstacles before starting your work. Be aware of the machine size and have enough space available to allow for operation. Never operate the machine at high speeds in crowded places.

Emphasize the importance of using correct procedures when working around and operating the machine. Do not let children or unqualified persons operate the machine. Keep others, especially children, away from your area of work. Do not permit others to ride on the machine.

Make sure the machine is in the proper operating condition as stated in the Operator Manual. Make sure the machine has the correct equipment required by local regulations.

All equipment has a limit. Make sure you understand the speed, brakes, steering, stability, and load characteristics of this equipment before you start.

1.2.7.2 General information

When parking, park the machine on a solid level surface and lower the header to the ground. Put all controls in neutral, center and lock the steering wheel, and apply the park brake. Stop the tractor engine and take the key with you.



WARNING:
Do not leave the machine unattended with the header raised. Lower the header fully before leaving the machine. A sudden loss of hydraulic pressure can cause the header to drop without warning.

Make sure the machine is in the proper operating condition according to the Operator Manual.

Always operate the machine with the control console turned on.

Do not dismount from moving machinery.

Stay off slopes too steep for operation.

Be aware of the size of the machine and have enough space available to allow for operation.

Stay off slopes too steep for operation. Keep the header as low as possible while going down hills. Never suddenly reverse the wheels to stop or back up.

Where possible avoid operating the machine near ditches, embankments, and holes. Reduce ground speed when operating on rough, slippery, or muddy surfaces and when turning or crossing slopes.

Avoid contact with electrical power lines. Contact with electrical power lines can cause electrical shock, resulting in very serious injury or death.

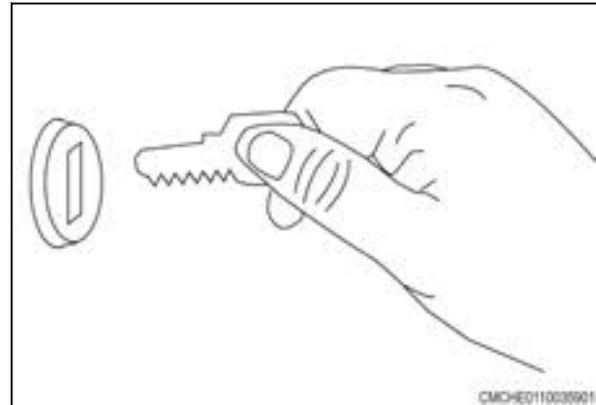

Fig. 4

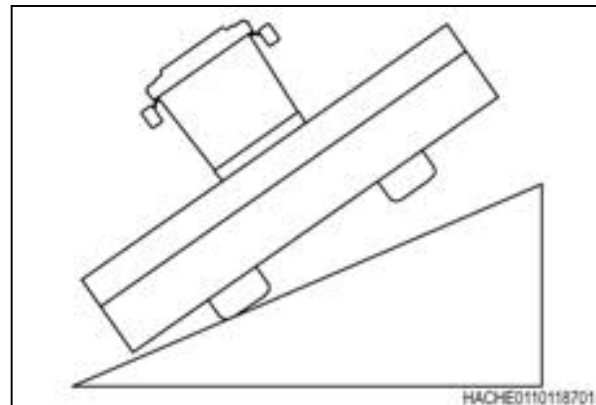

Fig. 5

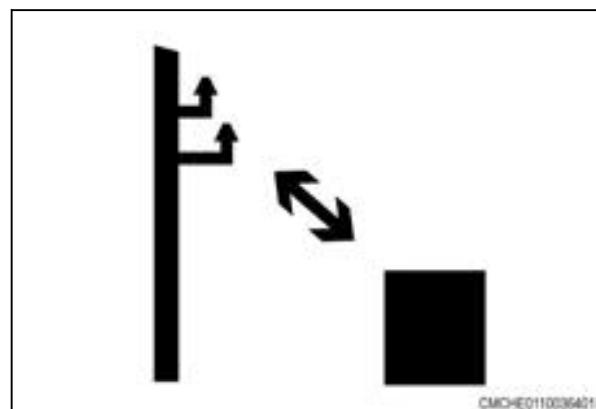

Fig. 6

1.2.7.3 Personal protective equipment

Wear all personal protective equipment (PPE) and protective clothing issued to you or called for by job conditions and country/local regulations. PPE includes, but is not limited to, equipment to protect eyes, lungs, ears, head, hands and feet when operating, servicing, or repairing equipment.

Always keep hands, feet, hair, and clothing away from moving parts. Do not wear loose clothing, jewelry, watches, or other items that could entangle in moving parts. Tie up long hair that can also entangle in moving parts.

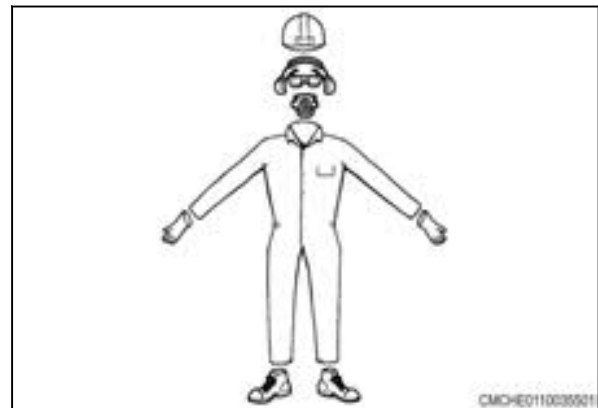

Fig. 7

1.2.7.4 Seat instructions

Securely fasten the seat belt before operating the machine. Always remain seated and have the seat belt fastened while operating the machine. Replace the seat belts when they become worn or broken.

Never wear a seat belt loosely or with slack in the belt system. Never wear the seat belt in a twisted condition or pinched between the seat structural members.

When using the instructional seat, if equipped, securely fasten the seat belt. The instructional seat is to be used only to train new operators or diagnose a problem. The instructional seat is only intended for short periods of use. Extra riders, especially children, are not permitted on the machine.

When the instructional seat is used the machine must be driven at a slower speed and on level ground. Avoid quick starts, stops, and sharp turns. Avoid driving on highways or public roads.

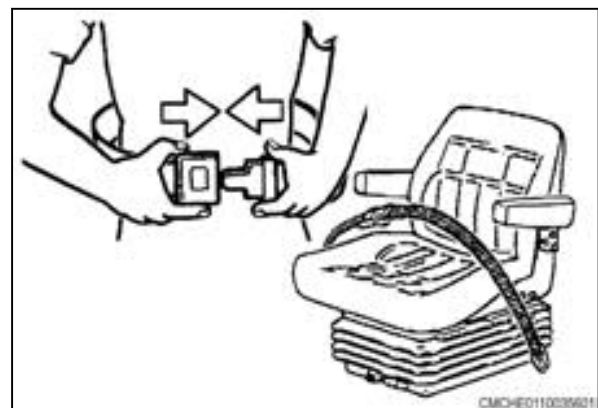

Fig. 8

1.2.7.5 Shield and guards

All shields and guards must be in the correct operating position and in good condition.

Do not open, remove, or reach around shields while the engine is operating. Entanglement in rotating belts and components can cause serious injury or death. Stay clear of rotating components.



Fig. 9

Do not operate the machine with the drive shaft shields open or removed. Entanglement in rotating drive shafts can cause serious injury or death. Stay clear of rotating components.

Make sure rotating guards turn freely.



Fig. 10

Do not make adjustments to the roll tension with the header engaged.

When making adjustments to the roll pressure, turn off the header. Lower the header to the ground and engage the park brake. Set the engine to low idle.

1.2.7.6 Exhaust warning

Never operate the engine in a closed building unless the exhaust is vented outside.

Do not tamper with or modify the exhaust system with unapproved extensions.



Fig. 11

1.2.7.7 Flying debris



WARNING:
Be careful when operating along the side of a road or building. Rocks or other debris can be thrown from the machine during operation possibly resulting in injury.

Never stand near the machine during operation. Debris can be thrown from the machine during operation possibly resulting in injury.



Fig. 12

**Thank you very much for
your reading. Please Click
Here. Then Get COMPLETE
MANUAL. NO WAITING**



NOTE:

**If there is no response to
click on the link above,
please download the PDF
document first and then
click on it.**

1.2.7.8 Handrails

Face the ladder and use the handrails when getting on or off the machine.



Fig. 13

1.2.7.9 Agricultural chemicals

Agricultural chemicals can be very hazardous. Improper use of fertilizer, fungicides, herbicides, insecticides and pesticides can injure people, plants, animals, soil and other people's property.

Always read and follow all manufacturers' instructions before opening any chemical container.

Even if you think you know the instructions, read and follow instructions each time you use a chemical.

Use the same precautions when adjusting, servicing, cleaning or storing the machine as used when installing chemicals into the hoppers or tanks.

Inform anyone who comes in contact with chemicals of the potential hazards involved and the safety precautions required.

Stand upwind and away from smoke from a chemical fire.

Store or dispose of all unused chemicals only in a manner as specified by the chemical manufacturer.

1.2.8 Travel on public roads

Make sure you understand the speed, brakes, steering, stability, and load characteristics of this machine before you travel on public roads.

Use good judgment when traveling on public roads. Maintain complete control of the machine at all times. Never coast down hills.

The maximum speed of farm equipment is governed by local regulations. Adjust travel speed to maintain control at all times. See the specifications for the maximum speed for this machine.

Familiarize yourself with and obey all road regulations that apply to your machine. Consult your local law enforcement agency for local regulations regarding movement of farm equipment on public roads. Use head lamps, flashing warning lamps, tail lamps and turn signals, day and night, unless prohibited by local law.

Make sure all the flashers are operating prior to driving on the road. Make sure reflectors are correctly installed, in good condition, and wiped

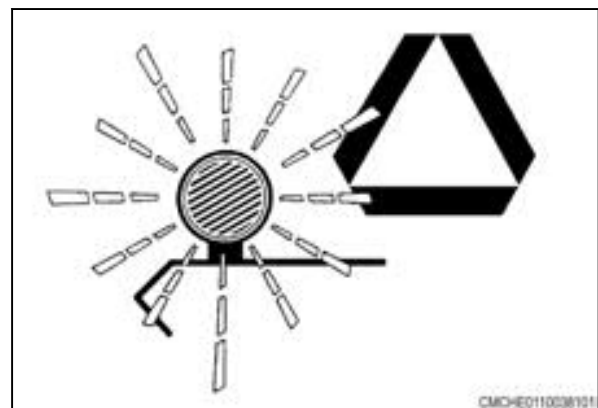

Fig. 14

clean. Make sure the Slow Moving Vehicle (SMV) emblem is clean, visible, and correctly mounted on the rear of the machine.

Always travel with the header as low as possible. Do not drive with header up and the lift cylinder stops in the locked position.

Be aware of other traffic on the road. Keep well over to your own side of the road and pull over, whenever possible, to let faster traffic pass.

Be aware of the overall width, length, height, and weight of the machine. Be careful when transporting the machine on narrow roads and across narrow bridges.

Watch for overhead wires and other obstructions. Avoid contact with electrical power lines. Contact with electrical power lines can cause electrical shock, resulting in very serious injury or death.

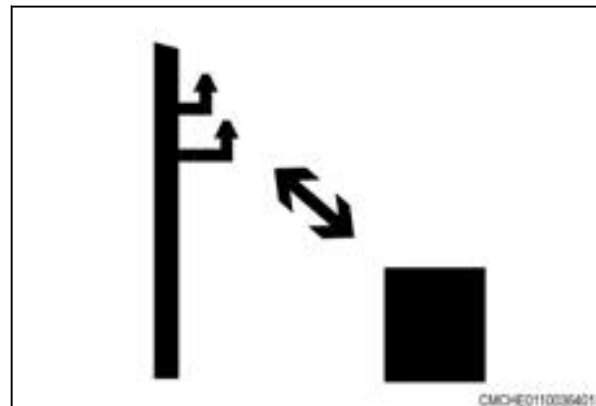

Fig. 15

1.2.9 Maintenance

1.2.9.1 General maintenance information

Before doing any unplugging, lubricating, servicing, cleaning, or adjusting:

- Park the machine on a solid level surface.
- Make sure all controls are in the neutral position and apply the park brake.
- Make sure all implements and attachments have been lowered to the ground.
- Stop the engine and take the key with you.
- Look and Listen! Make sure all moving parts have stopped.
- Put blocks in front of and behind the wheels of the machine before working on or under the machine.

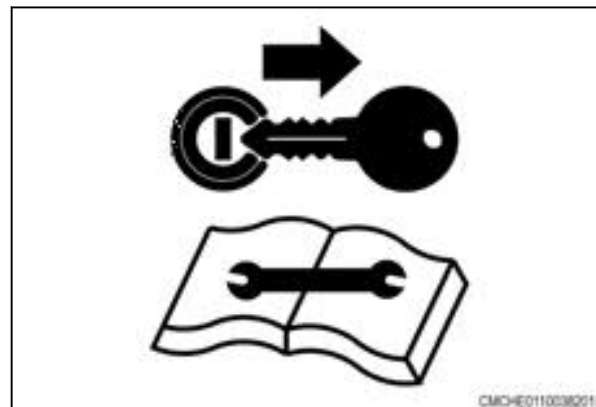

Fig. 16

Do not pull crop or any other object from the machine while the machine engine is running. Moving parts can pull you in faster than you can move away.

Check all nuts and bolts periodically for tightness, especially wheel mounting hardware.

Do not attempt to service or adjust the machine until all moving parts have stopped.

After unplugging, lubricating, servicing, cleaning, or adjusting the machine make sure all tools and equipment have been removed.

Make sure electrical connectors are clean and free of dirt or grease before connecting.

Check for loose, broken, missing, or damaged parts. Make sure the machine is in good repair. Make sure all guards and shields are in position.

Never service, check or adjust drive chains or belts while the engine is running.



Fig. 17

Do not operate the machine with the drive shaft shields open or removed. Entanglement in rotating drive shafts can cause serious injury or death.

Stay clear of rotating components.

Make sure rotating guards turn freely.

A loose yoke can slip off a shaft and result in injury to persons or damage to the machine.

When installing a quick disconnect yoke, the spring activated locking pins must slide freely and be seated in the groove on the shaft. Pull on the driveline to make sure the quick disconnect yoke can not be pulled off the shaft.



Fig. 18

Remove spilled oil, antifreeze or fuel immediately from the steps, platform, and other access areas.

Keep all access areas clean and free of obstructions.



Fig. 19