

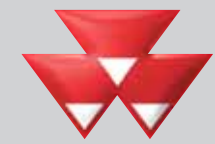

***MF 6100 Series  
Operators manual  
Repair Manual  
Workshop Manual***

## **Massey Ferguson Technology**

**Innovations that put you in complete control  
VISIBLE-RESULTS**



**MASSEY FERGUSON**

# **WORKSHOP SERVICE MANUAL**

## **CONTENTS**

- 1 - Introduction - Specifications
- 2 - Splitting the tractor
- 3 - Engine and equipment
- 4 - Clutch
- 5 - Gearbox
- 6 - Rear axle
- 7 - Power Take Off
- 8 - Front axle 2 and 4WD
- 9 - Hydraulics
- 10 - Electrical equipment
- 11 - Electronics
- 12 - Cab and Equipment
- 13 - Accessories
- 14 - Service Tools



# **1 . INTRODUCTION**

## **Contents**

**1 A01 INTRODUCTION**





## ***Introduction***

### *1 A01 Introduction*

#### CONTENTS

<b>A.</b>	<b>Using the manual</b> _____	<b>2</b>
<b>B.</b>	<b>Specifications</b> _____	<b>3</b>
<b>C.</b>	<b>Chassis dimensions and mounting points</b> _____	<b>16</b>
<b>D.</b>	<b>Safety precautions</b> _____	<b>17</b>
<b>E.</b>	<b>Practical advice</b> _____	<b>19</b>
<b>F.</b>	<b>Installation instructions</b> _____	<b>22</b>
<b>G.</b>	<b>Conversion table</b> _____	<b>23</b>
<b>H.</b>	<b>Sealants</b> _____	<b>31</b>
<b>I.</b>	<b>Tightening torques</b> _____	<b>31</b>



1A01.2



## Introduction

### A . Using the manual

#### General

The purpose of this manual is to assist Distributors and Dealers in the efficient installation, maintenance and repair of MASSEY FERGUSON machinery. Carrying out the procedures as detailed, together with the use of special tools where appropriate, will enable the operations to be completed within the time stated in the repair time schedule.

#### Page numbering

Example : 7C01-3

This manual is divided into parts and sections. Each page contains the following information :

7 = Section

C = Part

01 = Sequence number within the Part

3 = Page number within the Part

The issue number and the date are indicated at the bottom of the page.

#### Using the manual

To assist with locating information, each section of the manual is preceded by an index listing the Parts contained in that section.

The preliminary operations to be carried out in order to reach the item involved are listed at the beginning of each Part.

Items are indicated by means of identification marks (circles, squares, triangles).

#### Meaning of identification marks

circle ○ (..) identifies part only

square □ [..] identifies part and indicates an adjustment

triangle △ /.. identifies part and indicates an important point to be noted during removal or refitment

#### Amendments

Amended pages will be issued carrying the same page number as previous pages : only the issue number and the date will change.

Old pages should be destroyed.

#### Special tools

Where the use of a special tool is necessary in an operation, the tool number is shown following the instruction requiring its use.

#### Repairs and replacements

When parts have to be replaced, it is essential that only genuine MASSEY FERGUSON parts are used.

Attention is particularly drawn to the following points concerning repairs and the fitting of replacement parts and accessories.

Safety features embodied in the tractor may be impaired if other than genuine parts are fitted.

In certain territories, legislation prohibits the fitting of parts not to the tractor manufacturer's specification.

Torque wrench setting figures given in the Workshop Manual must be strictly adhered to. Locking devices must be fitted where specified. If the efficiency of a locking device is impaired during removal it must be renewed.

The tractor warranty may be invalidated by the fitting of other than genuine MASSEY FERGUSON parts. All MASSEY FERGUSON replacement parts have the full backing of the manufacturer's warranty. MASSEY FERGUSON Distributors and Dealers are obliged to supply only genuine service parts.

#### Repair time schedule

The sections in the repair time schedule are identical to those in the workshop manual. The Repair Time Schedule is available, under publication number 3378043M1.



**Introduction**

**B . Specifications**

**Engine**

Characteristics	MF 6110	MF 6120	MF 6130	MF 6140	MF 6150	MF 6160	MF 6170	MF 6180	MF 6190
PERKINS Model	4.41	4.41	1004.4TLR	1004.4T2	1004-4THR2	1006-6 HR4	1006-6.HR3	1006-6TLR2	1006-THR2
Number of cylinders	4	4	4	4	4	6	6	6	6
Turbocharger	-	-	yes	yes	yes	-	-	yes	yes
Bore, (mm.)	101.1	101.1	100	100	100	100	100	100	100
Stroke, (mm.)	127	127	127	127	127	127	127	127	127
Cubic capacity (litre)	4100	4100	4000	4000	4000	6000	6000	6000	6000
Maxi. engine power DIN (KW)	51.5	58,9	62,6	66,2	69,9	73,5	81	88,3	95,6
P.T.O. power DIN (KW)	47	53	57	59,8	64	68	74	82,3	88,3
At engine speed of rev/min	2200	2200	2200	2200	2200	2200	2200	2200	2200
Maximum torque (Nm)	265	286	325	359	386	403	440	490	530
Engine speed at maximum torque	1400	1400	1400	1400	1200	1200	1200	1400	1400
Idling speed rev/min	750	750	750	850	850	850	850	850	1000
Maximum rated speed rev/min	2200	2200	2200	2200	2200	2200	2200	2200	2200
Maximum no load speed rev/min	2350	2350	2310	2310	2310	2310	2310	2310	2310
Permissible front P.T.O. power at 2200 rev/min (kW)	All the engine power						75		
Maximum torque							328		
Lubrication	Gear type pump - strainer on suction side and external canister type filter(s).								
Valves	Overhead, push-rod operated								
Valves clearance (Cold)									
- Inlet - mm (in)	0.30 (0.012)			0.20 (0.008)					
- Exhaust - mm (in)	0.30 (0.012)			0.45 (0.018)					
Engine oil cooler	no	no	yes	yes	yes	no	no	yes	yes

**Fuel system and air cleaner**

Supply pump	ACDELCO			
Fuel filter with sediment bowl	Yes			
Number of elements	1		2	
Injection pump	CAV	Lucas		Stanadyne
Injectors and nozzle holders	Lucas		CAV	Stanadyne
Cold weather starting	Thermostart			
Air Cleaner: Two-stage air filter with removable elements for servicing, with centrifugal prefilter and clogging indicator (warning lamp).				



1A01.4

## 6100 SERIES TRACTORS



### **Introduction**

#### **Electrical system**

Voltage:	12 volts negative earth.
Batteries:	2 maintenance free batteries.
Safety start:	operated by the clutch pedal.
Headlights:	European code 40/45 W
Sidelights:	5 W
Rear/brake lights:	21/5 W
Direction indicators:	21 W
Number plate light:	10 W
Work lamps:	55 W - iodine type H3
Instrument panel lighting and warning lights:	3 W - 2 W - 1.2 W
Roof light:	10 W

#### **Cooling**

Operation:	Centrifugal pump and pressurised radiator, regulated by thermostat Opening temperature : 82° C (179.2° F) controlled by thermostat.
Fan:	6110/6120/6130/6140/6150 : belt drive 6150: viscostatic 6160/6170/6180/6190 : viscostatic model gear driven water pump.
Belt deflection: (on the longest span)	19 mm (4 cyl. engine), 10 mm (6 cyl. engine).

#### **Transmission**

Clutch :	Spring-loaded multiple-disc clutch of oil bath type - 4 discs Pressure-loaded multiple-disc clutch of oil bath type - 5 discs
6110/6120/6130/6140/6150/6160 6170/6180/6190	- 16 or 32 speeds
Gearbox :	- 16 forward speeds
Without Dynashift :	- 16 reverse speeds - reverse shuttle (synchronised)
Creep gear (option)	Ratio 4 to 1
Super creep gear (option)	Ratio 7.8 to 1
Dynashift gearbox :	- 32 front speeds - 32 rear speeds - four selectable ratios without declutching - reverse shuttle (synchronised)



**VISIBLE-RESULTS**







**Introduction**

Road speeds at 2200 rev/min  
6110/6120/6130/6140 - 16.9 - 34 tyres

Speed	Range	Speed-shift	16 SPEED 30 KPH				16 SPEED 40 KPH			
			FORWARD		REVERSE		FORWARD		REVERSE	
			KPH	MPH	KPH	MPH	KPH	MPH	KPH	MPH
1	LOW 	Slow	1.91	1.19	1.86	1.16	2.45	1.52	2.38	1.48
		Fast	2.45	1.52	2.38	1.48	3.10	1.92	3.01	1.87
2		Slow	2.93	1.82	2.85	1.77	3.70	2.30	3.59	2.23
		Fast	3.70	2.30	3.59	2.23	4.68	2.91	4.55	2.83
3		Slow	4.05	2.52	3.94	2.45	5.12	3.18	4.97	3.09
		Fast	5.12	3.18	4.97	3.09	6.48	4.03	6.30	3.91
4		Slow	5.87	3.65	5.70	3.54	7.42	4.61	7.21	4.48
		Fast	7.42	4.61	7.21	4.48	9.38	5.83	9.12	5.67
5	HIGH 	Slow	7.78	4.83	7.56	4.70	9.83	6.11	9.55	5.94
		Fast	9.83	6.11	9.55	5.94	12.43	7.72	12.08	7.51
6		Slow	11.75	7.30	11.42	7.10	14.86	9.28	14.48	8.97
		Fast	14.85	9.23	14.43	8.97	18.77	11.67	18.25	11.34
7		Slow	16.26	10.10	15.80	9.82	20.56	12.79	19.98	12.42
		Fast	20.56	12.79	19.98	12.42	25.98	16.15	25.26	15.70
8		Slow	23.55	14.64	22.89	14.23	29.76	18.50	28.92	17.97
		Fast	29.76	18.50	28.92	17.97	37.62	23.38	36.57	22.72

6150/6160/6170 -16.9 - 38 tyres

Speed	Range	Speed-shift	16 SPEED 30 KPH				16 SPEED 40 KPH			
			FORWARD		REVERSE		FORWARD		REVERSE	
			KPH	MPH	KPH	MPH	KPH	MPH	KPH	MPH
1	LOW 	Slow	1.92	1.19	1.86	1.16	2.43	1.51	2.36	1.46
		Fast	2.43	1.51	2.36	1.46	3.07	1.91	2.98	1.85
2		Slow	2.90	1.81	2.81	1.74	3.67	2.28	3.57	2.21
		Fast	3.67	2.28	3.57	2.21	4.64	2.88	4.51	2.80
3		Slow	4.01	2.50	3.90	2.42	5.08	3.16	4.94	3.07
		Fast	5.08	3.16	4.94	3.07	6.42	3.99	6.24	3.88
4		Slow	5.81	3.62	5.64	3.50	7.35	4.57	7.15	4.44
		Fast	7.35	4.57	7.15	4.44	9.29	5.78	9.03	5.61
5	HIGH 	Slow	7.71	4.80	7.49	4.66	9.74	6.06	9.47	5.90
		Fast	9.74	6.06	9.47	5.90	12.31	7.66	11.96	7.43
6		Slow	11.64	7.24	11.31	7.03	14.72	9.15	14.31	8.89
		Fast	14.72	9.15	14.31	8.89	18.60	11.56	18.08	11.23
7		Slow	16.11	10.02	15.66	9.73	20.37	12.66	19.80	12.30
		Fast	20.37	12.66	19.80	12.30	25.74	16.00	25.02	15.55
8		Slow	23.33	14.50	22.67	14.09	29.49	18.33	28.66	17.81
		Fast	29.49	18.33	28.66	17.81	37.27	23.17	36.22	22.51





1A01.6

# 6100 SERIES TRACTORS





## Introduction

Road speeds at 2200 rev/min  
6180/6190 - 20.8 - 38 tyres

Speed	Range	Speed-shift	16 SPEED 30 KPH				16 SPEED 40 KPH			
			FORWARD		REVERSE		FORWARD		REVERSE	
			KPH	MPH	KPH	MPH	KPH	MPH	KPH	MPH
1	LOW 	Slow	2.54	1.57	2.53	1.57	2.54	1.57	2.53	1.57
		Fast	3.22	2.00	3.20	1.99	3.22	2.00	3.20	1.99
2		Slow	3.84	2.38	3.82	2.37	3.84	2.38	3.82	2.37
		Fast	4.86	3.02	4.83	3.00	4.86	3.02	4.83	3.00
3		Slow	5.32	3.30	5.29	3.28	5.32	3.30	5.29	3.28
		Fast	6.73	4.18	6.69	4.18	6.73	4.18	6.69	4.15
4		Slow	7.71	4.42	7.66	4.76	7.71	4.42	7.66	4.76
		Fast	9.74	6.05	9.69	6.02	9.74	6.05	9.69	6.02
5	HIGH 	Slow	10.22	6.35	10.16	6.31	10.22	6.35	10.16	6.31
		Fast	12.91	8.02	12.84	7.98	12.91	8.02	12.84	7.98
6		Slow	15.43	9.59	15.34	9.53	15.43	9.59	15.34	9.53
		Fast	19.51	12.12	19.39	12.05	19.51	12.12	19.39	12.05
7		Slow	21.36	13.27	21.23	13.19	21.36	13.27	21.23	13.19
		Fast	27.00	16.78	26.84	16.68	27.00	16.78	26.84	16.68
8		Slow	30.92	19.21	30.74	19.10	30.92	19.21	30.74	19.10
		Fast					39.09	24.29	38.86	24.15

Road speeds "Dynashift" at 2200 rev/min -  
6110 to 6140 - 13.6R38 tyres

RATIO		FORWARD		REVERSE		
		KPH	MPH	KPH	MPH	
	1	A	2.04	1.27	2.06	1.28
		B	2.39	1.49	2.41	1.50
		C	2.82	1.75	3.10	1.93
		D	3.30	2.05	3.33	2.07
	2	A	3.47	2.16	3.50	2.18
		B	4.06	2.52	4.10	2.55
		C	4.79	2.98	4.83	3.00
		D	5.61	3.49	5.66	3.52
	3	A	4.57	2.84	4.61	2.87
		B	5.34	3.32	5.39	3.35
		C	6.31	3.92	6.37	3.96
		D	7.38	4.59	7.45	4.63
4	A	6.18	3.84	6.24	3.88	
	B	7.23	4.49	7.30	4.54	
	C	8.54	5.30	8.62	5.36	
	D	9.99	6.21	10.08	6.27	
	1	A	7.65	4.76	7.72	4.80
		B	8.96	5.57	9.05	5.63
		C	10.57	6.57	10.67	6.64
		D	12.38	7.69	12.50	7.78
	2	A	13.00	8.08	13.13	8.17
		B	15.22	9.46	15.36	9.55
		C	17.97	11.16	18.14	11.28
		D	21.03	13.07	21.23	13.21
	3	A	17.12	10.64	17.28	10.75
		B	20.03	12.45	20.22	12.58
		C	23.65	14.69	23.88	14.85
		D	27.68	17.20	27.94	17.38
	4	A	23.16	14.39	23.38	14.54
		B	27.11	16.84	27.37	17.02
		C	32.00	19.88	32.31	20.10
		D	37.45	23.27	37.81	23.52

VISIBLE-RESULTS



# 6100 SERIES TRACTORS



1A01.7

## Introduction

### Road speeds "Dynashift" at 2200 rev/min - 6150 to 6170 - 16.9R38 tyres

RATIO	FORWARD		REVERSE		
	KPH	MPH	KPH	MPH	
<b>1</b>	A	2.04	1.27	2.06	1.28
	B	2.39	1.48	2.41	1.50
	C	2.82	1.75	3.10	1.93
	D	3.30	2.05	3.33	2.07
<b>2</b>	A	3.47	2.15	3.50	2.18
	B	4.06	2.52	4.10	2.55
	C	4.79	2.98	4.83	3.00
	D	5.60	3.48	5.65	3.51
<b>3</b>	A	4.56	2.83	4.60	2.86
	B	5.34	3.32	5.39	3.35
	C	6.30	3.92	6.36	3.96
	D	7.38	4.58	7.45	4.63
<b>4</b>	A	6.17	3.84	6.22	3.87
	B	7.22	4.49	7.29	4.53
	C	8.53	5.30	8.61	5.36
	D	9.98	6.20	10.07	6.26
<b>1</b>	A	7.65	4.75	7.72	4.80
	B	8.95	5.56	9.04	5.62
	C	10.56	6.56	10.66	6.63
	D	12.36	7.68	12.48	7.76
<b>2</b>	A	12.99	8.07	13.12	8.16
	B	15.20	9.45	15.34	9.54
	C	17.95	11.15	18.12	11.27
	D	21.00	13.05	21.20	13.19
<b>3</b>	A	17.10	10.62	17.26	10.74
	B	20.01	12.43	20.20	12.56
	C	23.62	14.68	23.84	14.83
	D	27.65	17.18	27.92	17.37
<b>4</b>	A	23.14	14.38	23.36	14.53
	B	27.08	16.83	27.34	17.01
	C	31.96	19.86	32.26	20.07
	D	37.41	23.25	37.77	23.49

### Road speeds "Dynashift" at 2200 rev/min - 6180/6190 - 18.4R38 tyres

RATIO	FORWARD		REVERSE		
	KPH	MPH	KPH	MPH	
<b>1</b>	A	2.09	1.30	1.97	1.23
	B	2.45	1.52	2.31	1.44
	C	2.89	1.80	2.72	1.69
	D	3.38	2.10	3.19	1.98
<b>2</b>	A	3.55	2.21	3.35	2.08
	B	4.16	2.58	3.92	2.44
	C	4.91	3.05	4.63	2.88
	D	5.75	3.57	5.42	3.37
<b>3</b>	A	4.68	2.91	4.41	2.74
	B	5.47	3.40	5.16	3.21
	C	6.46	4.01	6.85	4.26
	D	7.56	4.70	7.13	4.43
<b>4</b>	A	6.33	3.93	5.97	3.71
	B	7.41	4.60	6.99	4.35
	C	8.74	5.43	8.24	5.13
	D	10.23	6.36	9.65	6.00
<b>1</b>	A	7.84	4.87	7.39	4.60
	B	9.17	5.70	8.65	5.38
	C	10.83	6.73	10.21	6.35
	D	12.67	7.88	11.95	7.43
<b>2</b>	A	13.32	8.28	12.56	7.81
	B	15.59	9.69	14.70	9.14
	C	18.50	11.43	17.35	10.79
	D	21.54	13.38	20.31	12.63
<b>3</b>	A	17.53	10.89	16.53	10.28
	B	20.52	12.75	19.35	12.04
	C	24.22	15.05	22.84	14.21
	D	28.35	17.61	26.73	16.63
<b>4</b>	A	23.72	14.74	22.37	13.91
	B	27.76	17.25	26.18	16.28
	C	32.77	20.36	30.90	19.22
	D	38.36	23.83	36.17	22.50

VISIBLE-RESULTS



1A01.8

## 6100 SERIES TRACTORS



# Introduction

### Final reduction units

Reduction units :	epicyclic, in the rear axle housings.
Reduction ratios :	6110/6120/6130/6140 (normal duty) 4.714 to 1
	6150/6160/6170 (heavy duty) 5.077 to 1
	6180/6190 5.571 to 1

### Power take-off

Independent power take-off (IPTO)  
P.T.O. ratio

Proportional to the engine speed. Hydraulic clutch.  
540 rev/min at 1980 engine rev/min  
1000 rev/min at 2000 engine rev/min

Speed changing  
(according to model)

Either by changing shafts :  
- 540 rev/min shaft, 35 mm (1 3/8 in) diameter, 6 splines.  
- 1000 rev/min shaft, 35 mm (1 3/8 in) diameter, 21 splines  
Or by external selection lever on rear L.h.s.  
- shaft 35 mm - 6 splines

"Economy" independant power  
take-off (optional extra)

The normal 540 and 1000 rev/min p.t.o. speeds can be  
obtained at the above stated engine speeds or at 1550  
engine rev/min by selecting the "economy" ratio.  
Lever in the cab.

Control

Ground speed P.T.O.  
(optional extra)

An addition to the independent P.T.O.

Control

Lever in the cab.

Speed : MF 6110/6120/6130/6140

- 540 rev/min - 7.87 revolutions of the p.t.o. shaft for 1 turn of  
the wheel axle.  
- 1000 rev/min - 14.83 revolutions of the p.t.o. shaft for 1 turn  
of the wheel axle.

Speed : MF 6150/6160/6170

- 540 rev/mn - 8.48 revolutions of the p.t.o. shaft for 1 turn of  
the wheel axle.  
- 1000 rev/mn - 15.54 revolutions of the p.t.o. shaft for 1 turn  
of the wheel axle.

Speed : MF 6180/6190

- 540 rev/mn - 8.23 revolutions of the p.t.o. shaft for 1  
revolution of the wheel.  
- 1000 rev/mn - 15.08 revolutions of the p.t.o. shaft for 1  
revolution of the wheel.

Front power take-off (optional extra)

Control

Hydraulic clutch mechanism controlled by a button in  
the cab.

Ratio

1000 rev/min at 2040 engine rev/min. - 2.04. : 1

### Four-wheel drive front axle

Clutch mechanism  
Differential Lock

Hydraulic, electrically actuated by push button in the cab  
Front and rear differential lock-hydraulic with electrical control.



# Introduction

## Hydraulics

Two stage gear pump, driven directly by the engine, supplies :

### 1st Stage

This circuit supplies 29 l/min (6.4 Imp. gal/min) (7.6 US gal/min) at maximum engine speed.  
Maximum pressure : 17 bar

- Hydrostatic steering  
Hare/Tortoise range gear  
Differential lock (rear and front)  
I.P.T.O. clutch  
P.T.O. brake  
Front P.T.O. (if fitted)  
Four-wheel drive (if fitted)  
Top up of brake master cylinder and clutch master cylinder  
Clutch control valve (pressure loaded)  
Lubrication of gearbox, P.T.O. and rear axle  
Gearbox front unit (Speedshift or Dynashift)  
Electro-hydraulic reverse shuttle (if fitted)

### 2nd Stage

This circuit supplies 50 l/min (11 Imp. gal/min) (13.2 US gal/min)  
Maximum pressure : 185 bar

- Trailer brake supply  
Auxiliary hydraulic system  
Hydraulic lift.

### Filtration

External 150-micron throwaway, canister type suction strainer.  
External 15 micron High pressure filter.

## Hydraulic lift

Type : 3-point, Category 2or 3, with fixed, telescopic or quick attach hook type ball ends (according to model).  
Rams : 2. Lifting force (see charts)

**MF 6110/6120/6130/6140** - Rams Ø 57 mm (2.24 in)

Position of lift rod on lower links mm (in)	Length of lift rods mm (in)	Lower links horizontal Kg (Lb)	Lower links fully raised Kg (Lb)
508 (20)	565 (22.2) 765 (30.1)	2885 (6360) 3010 (6636)	3825 (8433) 3165 (6977)
608 (24)	565 (22.2) 765 (30.1)	- 3430 (7562)	4190 (9237) 3485 (7683)

**MF 6150/6160/6170** - Rams Ø 66 mm (2.59 in)

Position of lift rod on lower links mm (in)	Length of lift rods mm(in)	Lower links horizontal Kg (Lb)	Lower links fully raised Kg (Lb)
550 (21.6)	595 (23.4) 827 (32.5)	4350 (9590) 4276 (9427)	5194 (11451) 4308 (9497)
650 (25.6)	595 (23.4) 827 (32.5)	5740 (12654) 4788 (10556)	5689 (12541) 4703 (10368)

**MF 6150/6160** - Rams Ø 57 mm (2.24 in)

Position of lift rod on lower links mm (in)	Length of lift rods mm (in)	Lower links horizontal Kg (Lb)	Lower links fully raised Kg (Lb)
550 (21.6)	595 (23.4) 827 (32.5)	3192 (7037) 3138 (6918)	3812 (8404) 3162 (6971)
650 (25.6)	595 (23.4) 827 (32.5)	4213 (9286) 3514 (7747)	4175 (9204) 3452 (7610)

**MF 6180/6190** - Rams Ø 73 mm (2.87 in)

Position of lift rod on lower links mm (in)	Length of lift rods mm (in)	Lower links horizontal Kg (Lb)	Lower links fully raised Kg (Lb)
550 (21.6)	595 (23.4) 827 (32.5)	5425 (11960) 5000 (11023)	6510 (14352) 5087 (11215)
650 (25.6)	595 (23.4) 827 (32.5)	8090 (17835) 5717 (12604)	7117 (15690) 5595 (12335)



1A01.10

## 6100 SERIES TRACTORS



### Introduction

#### Brakes

Type : Oil immersed single disc per wheel, 343 mm (13.50 in), outside diameter. Inside diameter of lining :  
 6110/6120/6130/6140 : 296 mm (11.65 in)  
 6150/6160/6170/6180/6190 : 274,5 mm (10.81 in)

Operation : Hydraulic, from two master cylinders, automatic adjustment.  
 Handbrake : Operates on the rear axle bevel gear.  
 Trailer brake : According to model by an hydraulic valve.

#### Differential lock - Rear axle

Type : Positive clutch  
 Control : Hydraulic, with electrical control.

#### Steering

Type : Hydrostatic fixed or tiltable telescopic steering column. One double action central ram

Theoretical turning circle	6110/20/30/40	6150	6160	6170/80/90
Tyres *	13.6-24	13.6-28	13.6-28	14.9-28
- 2 WD	•	•	•	•
- 4 WD	•	•	•	•
Track adjustments (m)	- 1,75	- 1,85	1,85	2,05
Angle	57°	55°	55°	55°
Radius tyres (outer)				
- without braking (m)	- 4,37	- 4,60	4,94	4,94

\* with front axle disengaged

#### Wheels

FRONT 2-wheel drive pressed steel  
 4-wheel drive pressed steel  
 REAR pressed steel with manual adjustment or cast with power adjust variable track (P.A.V.T.), or manual adjustment.



## Introduction

### Tyres

Compatibility of front/rear tyres of 4-wheel drive tractors same make and model.

Tyres	Front	Rear	Front	Rear	Front	Rear
	11.2R28	13.6R38	13.6R28	16.9R38	420-70R24	520-70R34
		16.9R34		18.4R34	440-65R28	540-65R38
		18.4R30	14.9R24	13.6R38	420-70R28	520-70R38
(1) 12.4R24	13.6R38	16.9R30		18.4R34	480-65R28	520-70R38
		18.4R30	14.9R28	18.4R38		600-65R38
	13.6R24	13.6R38	(1) 380-70R24	480-70R34		
		16.9R34	380-70R28	480-70R38		

**NOTE :** The data in this table is not binding. Ask your dealer for further information on other possible choices.

(1) 6110/6120/6130/6140/6150 only

### Water Ballasting (75° fill)

Front tyres	Rim	Litre	Imp. gal.	US gal.	Kg	lb
11.2R28	W9 x 28	98	21.56	25.9	98	216
13.6R24	W12 x 24	139	30.60	36.7	139	306
13.6R28	W11 or W12 x 28	150	33.00	39.6	150	330
14.9R24	W12 x 24	178	39.20	47.0	178	392
14.9R28	W12 x 28	200	44.00	52.8	200	440
380-70R24	W12 x 24	161	35.40	42.5	161	354
380-70R28	W12 x 28	174	38.30	45.9	174	383
440-65R28		202	44.44	52.52	202	444
420-70R24	W12 x 24	192	42.20	50.7	192	423
420-70R28	W12 x 28	214	47.10	56.5	214	471
480-65R28	W12 x 28	255	56.10	67.3	255	561

Rear tyres	Rim	Litre	Imp. gal.	US gal.	Kg	lb
13.6R38	W11 or W12 x 38	184	40.50	48.6	184	405
16.9R30	W14 x 30	260	57.20	68.7	260	472
16.9R34	W14 or W15 x 34	285	62.70	75.3	285	627
16.9R38	W14 or W15 or W16 x 38	304	66.80	80.3	304	669
18.4R30	W14 or W15 or W16 x 30	304	66.80	80.3	304	669
18.4R34	W15 or W16 x 34	345	75.90	91.1	345	760
18.4R38	W15 or W16 x 38	386	84.90	102.0	386	850
480-70R34	W15 x 34	349	76.70	92.2	349	768
480-70R38	W15 x 38	375	82.50	99.0	375	826
520-70R34	W15 x 34	424	93.29	112.0	424	934
520-70R38	W15 x 38	452	99.45	119.4	452	995
540-65R38	W14, 15 or 16 x 38	386	84.92	100.36	386	849
600-65R38	W15 or W16 x 38	521	115.00	135.46	521	1146



1A01.12

# 6100 SERIES TRACTORS



## Introduction

### Capacities

Fuel tank : .....	6110/6120/6130/6140 :	130 l (28.60 Imp. gal.) (34.34 US gal.)
.....	6150/6160/6170/6180/6190 :	160 l (35.20 Imp. gal.) (42.27 US gal.)
Cooling system : .....	6110/6120/6130/6140/6150 :	17 l (3.74 Imp. gal.) (4.49 US gal.)
.....	6160/6170/6180/6190 :	25 l (5.50 Imp. gal.) (6.60 US gal.)
Engine sump : .....	6110/6120/6130/6140/6150 :	7,4 l (1.63 Imp. gal.) (1.95 US gal.)
.....	6160/6170/6180/6190 :	14,8 l (3.26 Imp. gal.) (3.91 US gal.)
Transmission/rear axle :* .....	6110/6120/6130/6140/6150/6160 :	62 l (13.66 Imp. gal.) (16.4 US gal.)
.....	6170/6180/6190 :	68 l (15 Imp. gal.) (18 US gal.)
Front axle assembly : .....	6110/6120/6130/6140/6160/6170/6180 :	6 l (1.32 Imp. gal.) (1.58 US gal.)
.....	6150 :	9 l (1.98 Imp. gal.) (2.38 US gal.)
.....	6190 :	6,7 l (1.47 Imp. gal.) (1.77 US gal.)
Front final reduction units (each) : .....	6110/6120/6130/6140 :	1 l (0.22 Imp. gal.) (0.26 US gal.)
.....	6150/6160 :	1,2 l (0.26 Imp. gal.) (0.32 US gal.)
.....	6170/6180/6190 :	2 l (0.44 Imp. gal.) (0.53 US gal.)

\* When working on steep slopes 10 l (2.2 Imp. gal.) (2.7 US gal.) of oil can be added.

### Front and rear static axle load limits - Kg (lb) at 1,5 bar (21.77 PSI) pressure

Type	Front		Rear	
	Kg (lb)	mm (in)	Kg (lb)	mm (in)
<b>2 WD</b> Normal duty				
6110/6120/6130/6140/6150	3800 (8377)	track 1,383 (54.45)	6340 (13977)	track 1,772 (69.76)
Heavy duty				
6150/6160/6170	4350 (9590)	track 1,484 (58.42)	6340 (13977)	track 1,772 (69.76)
6180/6190	4350 (9590)	track 1,484 (58.42)	7600 (16755)	track 1,835 (72.25)
<b>4 WD</b>				
6110/6120/6130/6140/6150	4000 (8818)	track 1,650 (64.96)	6340 (13977)	track 1,772 (69.76)
6160/6170	5000 (11023)	track 1,800 (70.87)	6340 (13977)	track 1,772 (69.76)
6180	5000 (11023)	track 1,800 (70.87)	7600 (16755)	track 1,835 (72.25)
6190	6000 (13228)	track 1,920 (75.60)	7600 (16755)	track 1,835 (72.25)





# Introduction

## Dimensions and weights

CHARACTERISTICS mm (in) - Kg (lb)	6110		6120/6130/6140		6150		6160/6170		6180		6190	
	2WD	4WD	2WD	4WD	2WD	4WD	2WD	4WD	2WD	4WD	2WD	4WD
A Wheelbase	2371 (93.34)	2375 (93.35)	2371 (93.34)	2375 (93.35)	2549 (100.35)	2553 (100.51)	2696 (106.10)	2699 (106.25)	2696 (106.10)	2699 (106.25)	2696 (106.10)	2699 (106.25)
B Overall length with drawbar	3995 (117.9)	4069 (160.2)	3995 (117.9)	4069 (160.2)	4137 (162.87)	4137 (162.87)	4320 (170)	4472 (176)	4402 (173.3)	4402 (173.3)	4527 (178.2)	4527 (178.2)
C Height to roof (cab tractor)	2627 (103.4)	2627 (103.4)	2627 (103.4)	2627 (103.4)	2724 (107.2)	2724 (107.2)	2755 (108.5)	2755 (108.5)	2768 (109)	2768 (109)	2908 (114.5)	2908 (114.5)
D Overall width (1)	2570 (101.2)	2570 (101.2)	2570 (101.2)	2570 (101.2)	2570 (101.2)	2570 (101.2)	2570 (101.2)	2570 (101.2)	2733 (107.6)	2733 (107.6)	2832 (111.5)	2832 (111.5)
E Ground clearance (under drawbar Frame)	385 (15.2)	385 (15.2)	385 (15.2)	385 (15.2)	385 (15.2)	385 (15.2)	445 (17.5)	445 (17.5)	442 (17.4)	442 (17.4)	502 (19.8)	502 (19.8)
F Height to steering wheel	1971 (77.6)	1971 (77.6)	1971 (77.6)	1971 (77.6)	2023 (79.6)	2023 (79.6)	2068 (81.4)	2068 (81.4)	2110 (83)	2110 (83)	2250 (88.6)	2250 (88.6)
Total weight (with full tank, without extra weight steel wheels)	3565 (7859)	3840 (8465)	3565 (7859)	3840 (8465)	4120 (9080)	4400 (9698)	4440 (9800)	4675 (10320)	4190 (9249)	4590 (10132)	4805 (10607)	5040 (11126)
Rear tyres dimensions	16.9-34		16.9-34		16.9-34		18.4-38		16.9-38		20.8-38	

G Distance between flanges	Rear axle		Front axle		
			AG85	AG105	AG125
* Normal duty axle housing shaft Ø 82	1774 (69.84)		1669 (67)	1800 (70.86)	1800 (70.86)
* Shaft straight shaft Ø 82	1835 (72.34)				
	2230 (87.79)				
H Stud distance	Ø 82 shafts (3.23) 203,20 (8.00)		275 (10.8)		335 (13.20)
L Centring diameter	149,35 (5.88)				280,8 (11.04)
I Stud length					
Wheel with steel hub	41 (1.61)		43 (1.70)	43 (1.70)	55 (2.16)
Wheel with cast iron hub	66 (2.60)				
J Stud diameter	M 18 x 1,5		M 18 x 1,5		M 22 x 1,5
K Number of studs	8		8		10

(1) These dimensions are applicable for tractors adjusted for max. track  
\* 6180/6190 only

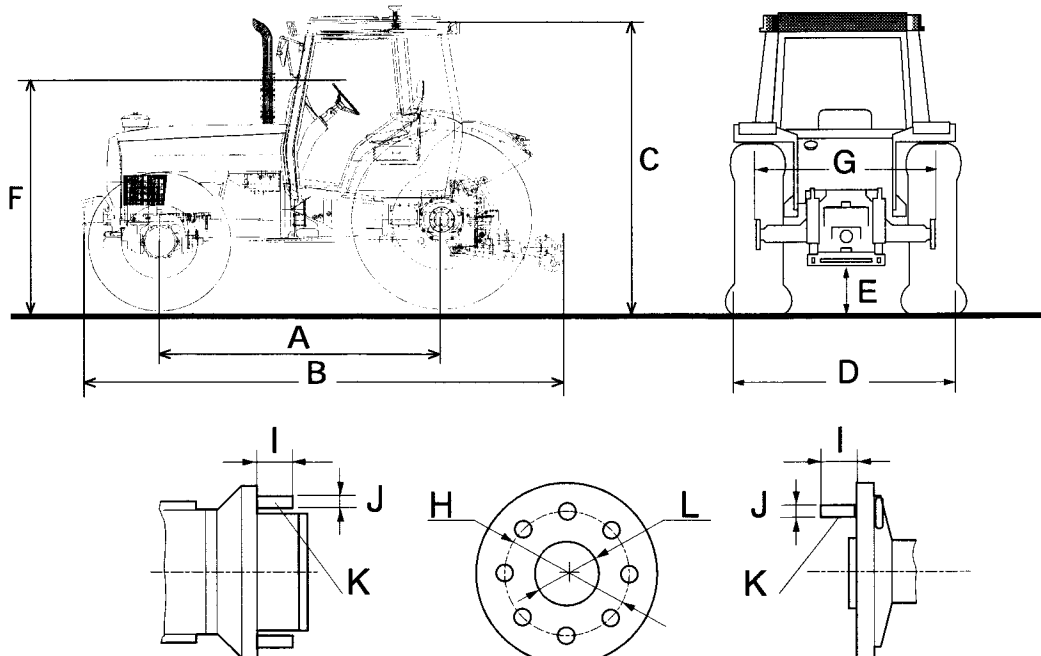

**VISIBLE-RESULTS**

Issue 2



1A01.14

## 6100 SERIES TRACTORS

**Introduction****C . Chassis dimensions and mounting points**

Ref.	6110/6130 6140	6150	6160/6170	6180/6190	Ref.	6110/6130 6140	6150	6160/6170	6180/ 6190
1	301,50	301,50	301,50	301,50	37	155	155	155	155
2	20,00	20,00	20,00	20,00	38	125	125	125	125
3	101,60	101,60	61,60	61,60	39	125	125	125	125
4	44,45	44,45	-	-	40	52	52	52	52
5	60,32	60,32	-	-					
6	101,60	101,60	-	-	41	52	52	52	52
7	481,00	570,00	621,40	621,40	42	79,5±2	79,5±2	79,5±2	96,5±2
8	112,40	201,40	49,60	49,60	43	46	46	46	46
9	25,25	25,25	6,27	6,27	44	190	190	190	190
10	70,00	70,00	101,60	101,60	45	100	100	100	100
					46	226	226	226	226
11	-	-	44,45	44,45	47	92	92	92	123
12	-	-	60,27	60,27	48	Ø149,35	Ø149,35	Ø149,35	Ø149,35
13	-	-	101,60	101,60	49	371,12	371,12	371,12	371,12
14	698,00	787,00	736,80	736,80					
15	340,05	429,05	370,60	370,60	50	320	320	320	320
16	571,75	571,75	771,50	771,50	51	110	110	110	110
17	896	896	896	896	52	130	130	130	130
18	890	890	890	890	53	65	65	65	65
19	567	567	567	567	54	142,75	142,75	142,75	142,75
20	-	-	94	94	55	20	20	20	20
					56	817	817	817	817
21	267	267	267	267	57	310	310	310	310
22	127,07	127,07	127,07	127,07	58	142,75	142,75	142,75	142,75
23	53	53	53	53	59	223	223	223	223
24	101,60	101,60	101,60	101,60	60	315	315	315	324
25	31,40	31,40	31,40	31,40					
26	101,60	101,60	101,60	101,60	61	100	100	100	
27	100	100	100	161	62	65	65	65	
28	260	260	260	280	63	65	65	65	
29	43	43	43	43	64	40 or 66	40 or 66	40 or 66	40 or 66
30	106	106	106	106	65	-	-	-	323,90
					66	-	-	-	76,20
31	224	224	224	224	67	-	-	-	120,60
32	128	128	128	128	68	-	-	-	241,30
33	1774	1774	1774	1835	69	3056	3231	3388	3388
34	-	-	-	2228					
35	-	-	-	2870	70	Ø203,2±0,3	Ø203,2±0,3	Ø203,2±0,3	Ø203,2±0,3
36	155	155	155	155	71		89		

A : 6 holes M20 through  
 B : 8 holes M20 x 38 deep  
 C : 12 holes M20 x 38 deep  
 D : 2 holes M20 through  
 E : 6 holes M16 x 31 deep  
 E' : 2 holes M16 x 25 deep  
 F : 2 holes diam. 37 - 37.16

G : 8 holes M18 x 31 deep  
 H : 8 studs M18 - 1.5  
 I : 4 holes M16 x 25 deep  
 J : 5 holes M20 x 35 deep  
 K : 4 holes M16 x 30 deep  
 L : 4 holes diam. 20.70 ± 0.12  
 through

v : 4 WD centerline  
 w : Crankshaft centerline  
 x : Differential centerline  
 y : Trumpet centerline  
 z : PTO centerline

**VISIBLE-RESULTS**



# Introduction

## 6 CYL.

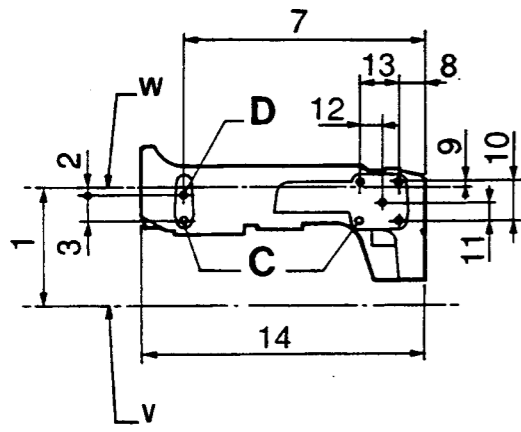

6160 - 70 - 80 - 90

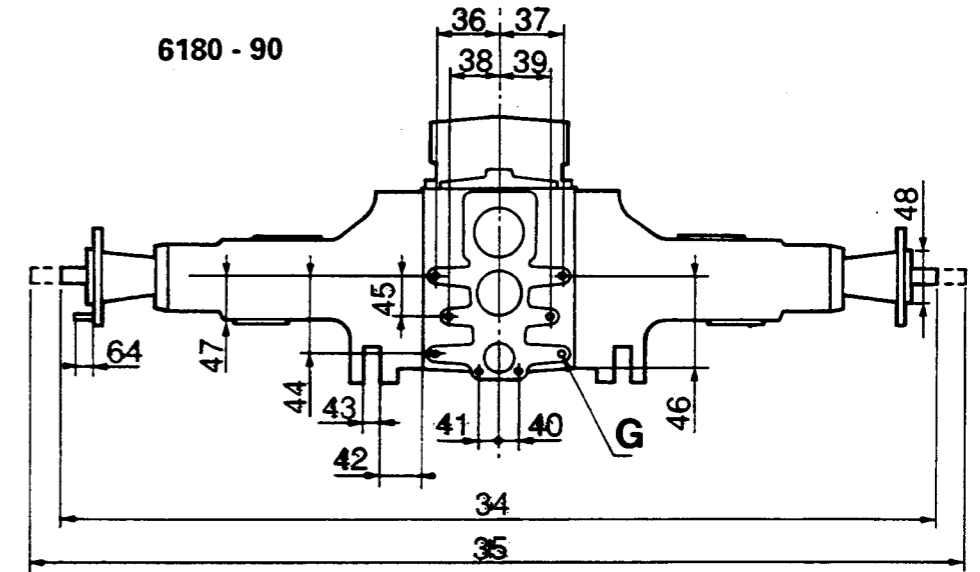
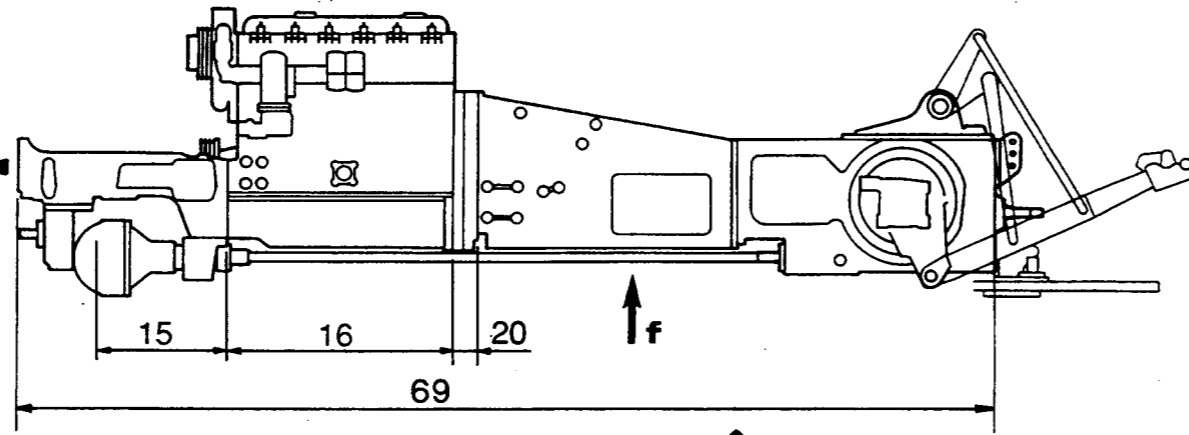

6180 - 90

AA

## 4 CYL.

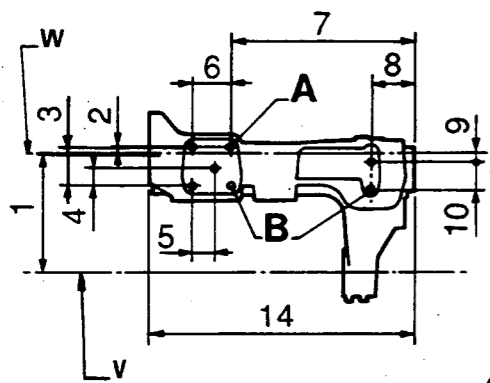

6110 - 20 - 30 - 40

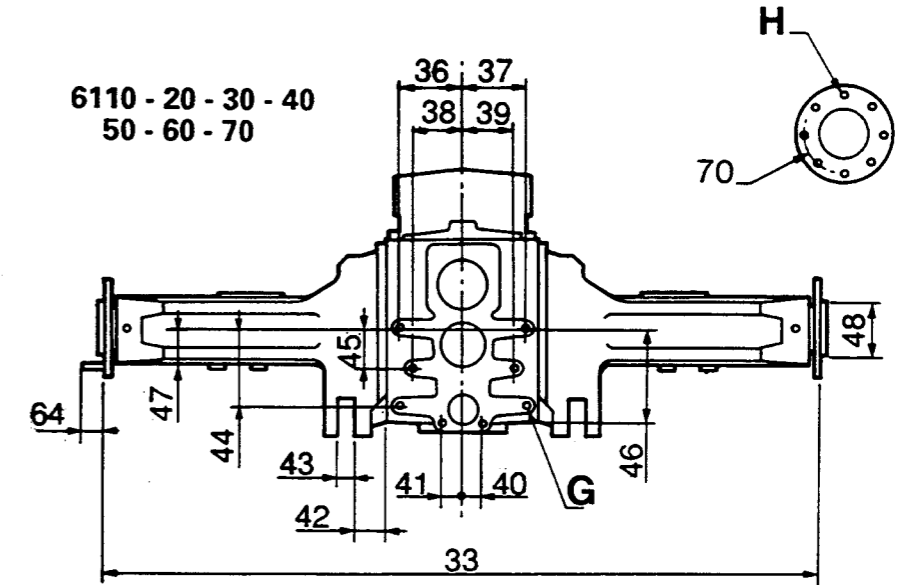
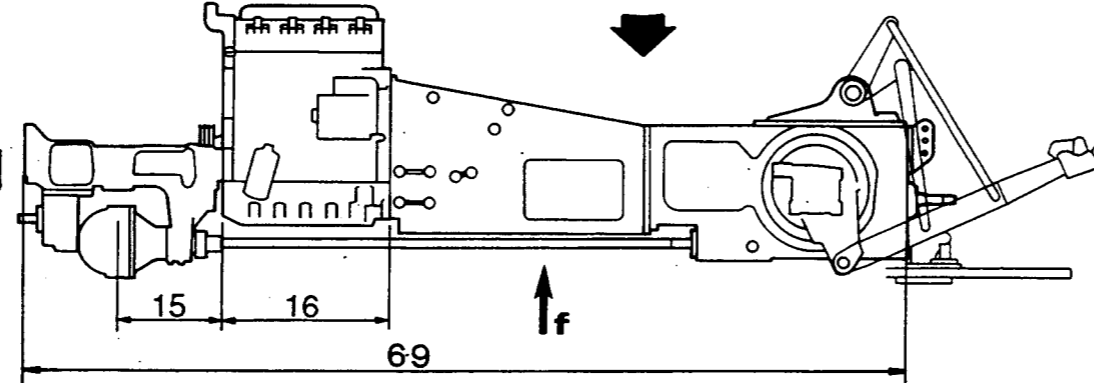

6110 - 20 - 30 - 40  
50 - 60 - 70

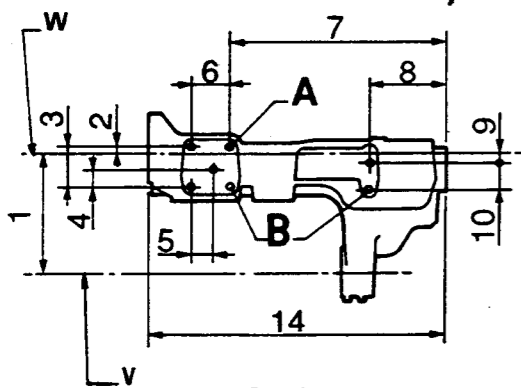

6150

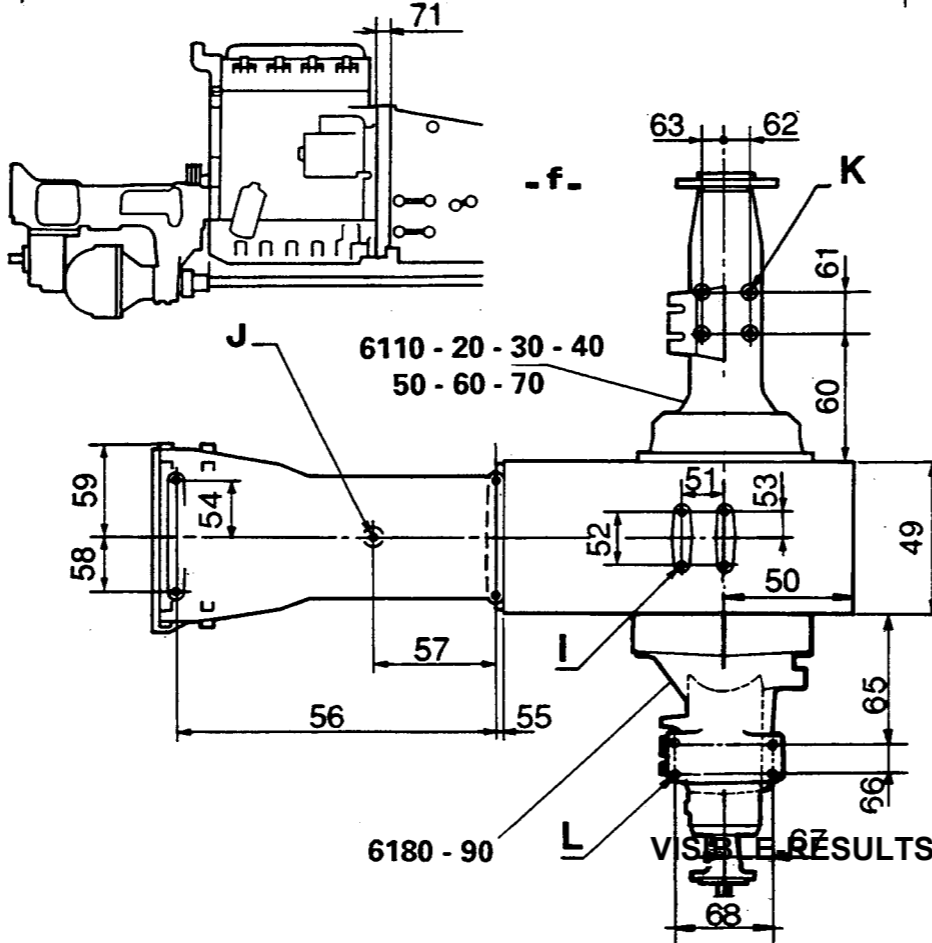

6110 - 20 - 30 - 40  
50 - 60 - 70

6180 - 90

VISIBLE RESULTS

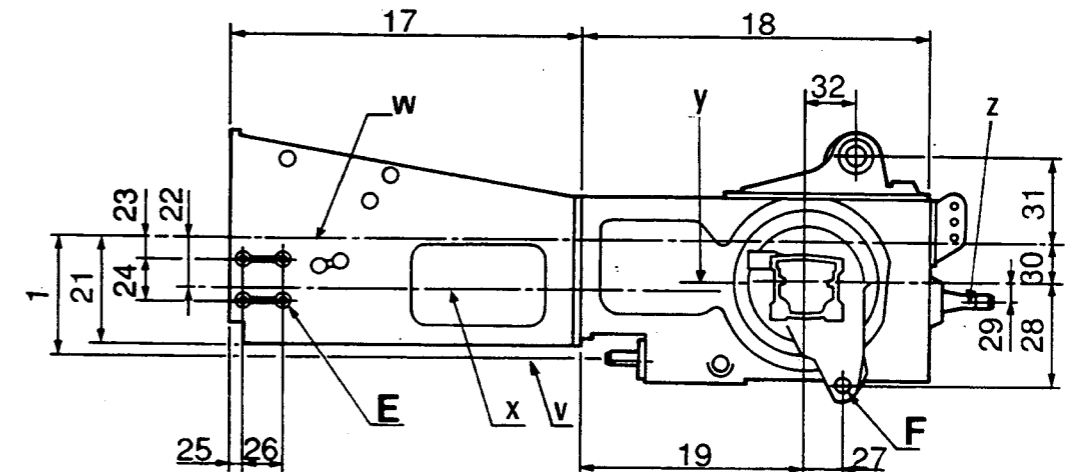

AA



# Introduction

## D. Safety precautions

When replacing a tractor part bearing a safety decal (yellow) a new safety sticker MUST be affixed onto the replacement part. A full list of the locations for all safety decals are specified below.

**G.B. CAUTION**



Before operating, read operator's instruction book thoroughly.  
Do not start engine until everyone is a safe distance from tractor and equipment.  
Keep all shields, covers and guards in place while engine is running.  
Keep hands, feet and clothing away from power driven or moving parts.

Always drive with due care and attention.

If differential lock does not disengage automatically, depress clutch pedal.  
Brake pedals must always be coupled together when independent brakes are not being used.

Before leaving tractor, apply parking brake, lower equipment, stop engine and remove key from starter switch.

When attaching equipment check operator's instruction book for front and rear axle load limits.  
Put the gears lever (1-2-3-4) in neutral position and put the reverse/forward lever in forward position or reverse position in order to use the external lift controls.  
Ensure that all wheel and rim nuts are tightened as specified in operator's instruction book.  
On public roads, use SMV emblem and flashing warning lights where required by law.

DO NOT REMOVE OR OBSCURE DECAL 3580321 M3

**WARNING**



Gears lever (1-2-3-4) must be in his neutral position and the reverse/forward lever in forward position or reverse position:  
- In order to use the external lift controls.  
- When the driver is not in his seat.

**WARNING**



When the tractor is stationary, it is imperative to fully apply the handbrake because leaving the tractor in gear will not prevent movement.  
When attempting to start the engine using a slave battery, ensure that the gear lever (1, 2, 3, 4) is in neutral.  
Never connect a slave battery directly to the starter motor

DO NOT REMOVE OR OBSCURE DECAL 3713705 M1



**G.B. WARNING**



High pressure steam and hot water.  
Remove filler cap with extreme care.

DO NOT REMOVE OR OBSCURE DECAL 3595685 M1

**G.B. CAUTION**

DO NOT REMOVE OR OBSCURE DECAL

**G.B. WARNING**



Before working on the tractor, disconnect negative leads to all batteries.

**WARNING**



Before removing any battery, disconnect all negative leads before positive leads.

DO NOT REMOVE OR OBSCURE DECAL 3595679 M1

**G.B. CAUTION**



Keep all shields, covers and guards fastened in place while engine is running.

**WARNING**



Beware hot parts

DO NOT REMOVE OR OBSCURE DECAL 3595678 M1

**G.B. CAUTION**



TO AVOID POSSIBLE TRACTOR OVERTURN, PULL ONLY FROM DRAWBAR OR LOWER LINKS OF THREE POINT HITCH

2752579 M1

**G.B. WARNING**



Always disengage PTO and stop engine before attaching or detaching PTO shafts or working on PTO driven equipment.

Always fit PTO cover when PTO is not in use.

**CAUTION**



Do not stand between tractor and equipment when operating controls.

Tow only with MF approved tractor drawbar or hitch

DO NOT REMOVE OR OBSCURE DECAL 3581563 M1

**CAUTION**



Belt for use only on tractors with safety structures.

DO NOT REMOVE OR OBSCURE DECAL 523784 M3

**G.B. WARNING**



Before working on the tractor or removing this cover, disconnect negative leads to all batteries.

**CAUTION**



Use seat belt at all times.  
Keep belt adjusted snugly.

DO NOT REMOVE OR OBSCURE DECAL 3580316 M1

**CAUTION**



Voir Manuel d'Utilisation. See Operator Instruction Book. Vedere Libretto d'Uso. Siehe Betriebsanleitung Ver Manual del Operator

3617574 M1

**CAUTION**



Do not short across starter terminals to start engine.  
Never start engine while standing on the ground.  
Start engine only with start key from operator's seat, ensuring that gearbox and PTO are in neutral with parking brake applied.

DO NOT REMOVE OR OBSCURE DECAL 3596432 M1

**G.B. WARNING**



If tractor is overturning, hold onto steering wheel.  
Do not leave seat



DO NOT REMOVE OR OBSCURE DECAL 3580315 M1

**CAUTION**



IT IS IMPERATIVE TO USE THE TRANSMISSION OIL RECOMMENDED IN THE OPERATING MANUAL



3713699M1



1A01.18

# 6100 SERIES TRACTORS



## Introduction

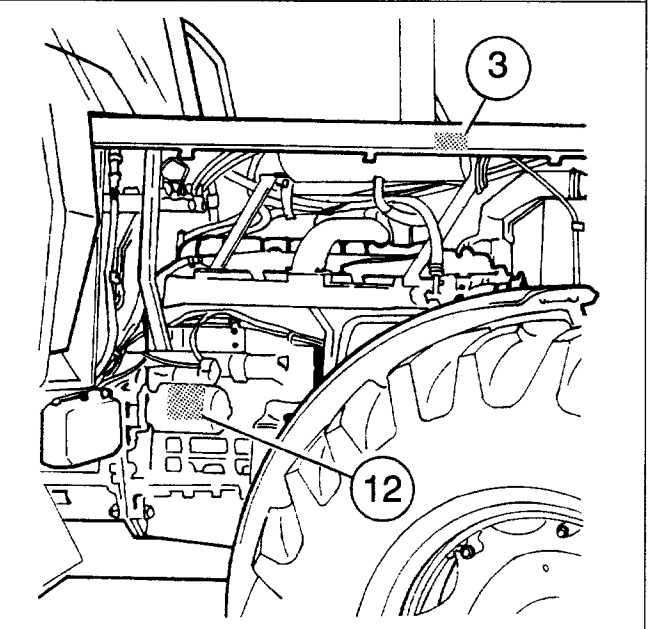
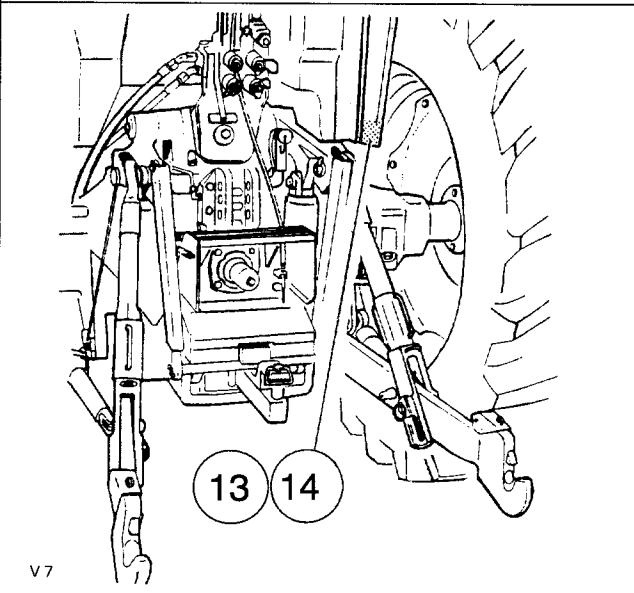
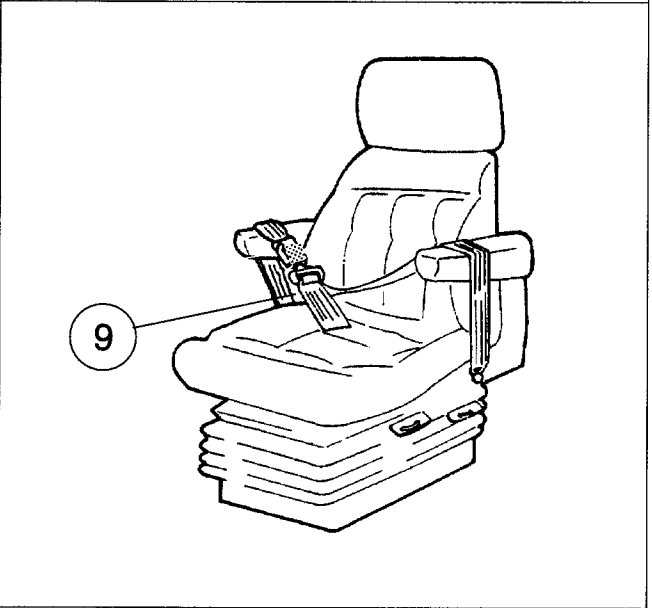
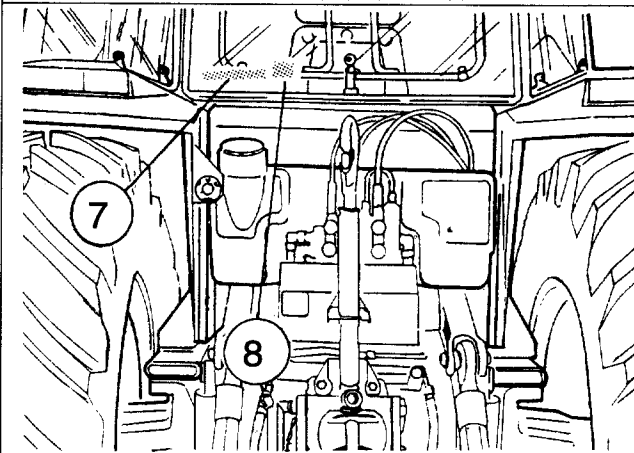
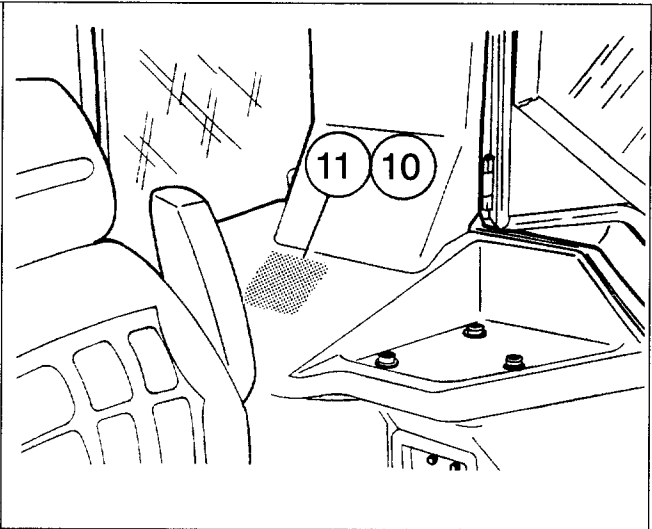
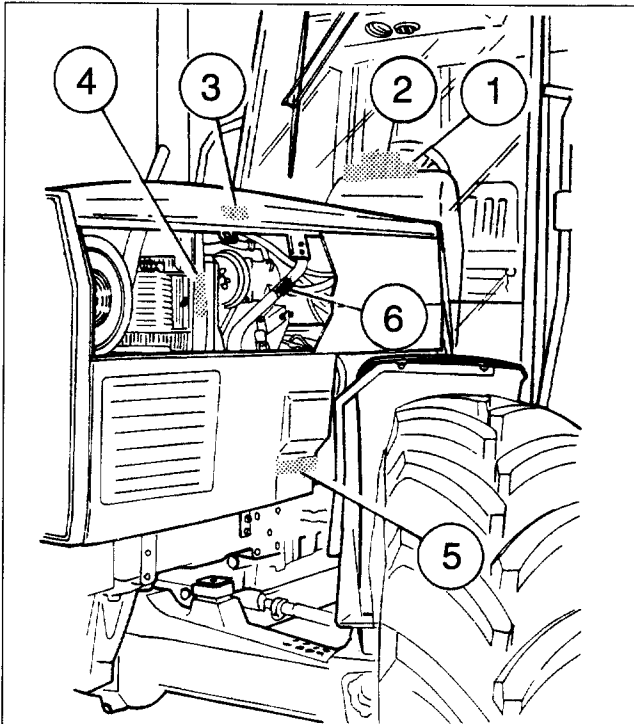

V7

**VISIBLE-RESULTS**



## Introduction

### E . Practical advice

#### Safety

Your safety and that of others must always be the first consideration when working around machines of any type.

Safety is a matter of thoroughly understanding the job to be done, the correct use of tools and equipment, and the application of good common sense.

#### Trouble-shooting

The following procedure, combined with the information contained in the workshop manual will be helpful in tracing faults accurately.

It consists of following a number of logical steps to locate and correct the problem.

1. Determine the problem.
2. List possible causes.
3. Differentiate the causes.
4. Conduct checks in logical order to determine the exact cause.
5. Consider approximate remaining service life against cost of parts and labour.
6. Make any necessary repair.
7. Recheck the parts and functions for correct operation.

#### Handling of heavy components

Unless otherwise specified, all removals should be accomplished using adjustable lifting equipment. All supporting slings must be parallel to each other and as near vertical as possible in relation to the object being lifted. However, where slings are of a far greater capacity than the weight of the load to be lifted, a triangular lifting arrangement may be used (2, 3 or 4 strands from a single ring beneath the hoist hook). When removing a component at an angle, remember that the capacity of an eyebolt is reduced when the angle between the supporting members and the object becomes less than 90° (correct and incorrect method of lifting).

Eyebolts and brackets must never be bent and must only work under tension. A length of pipe and a washer may be used to reduce tension on eyebolts.

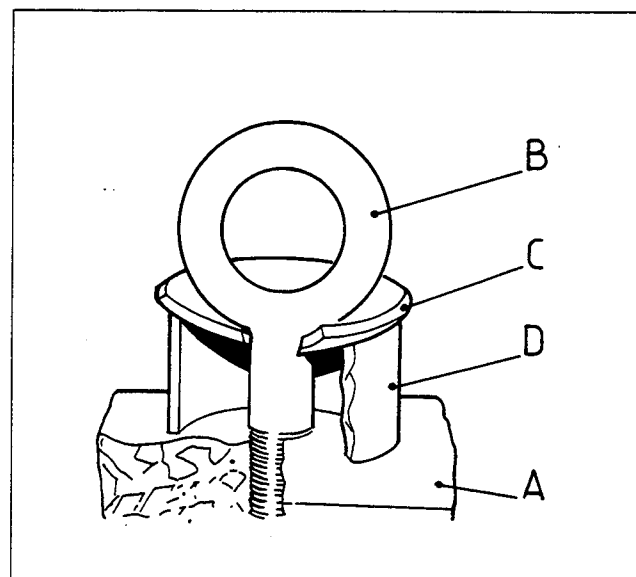
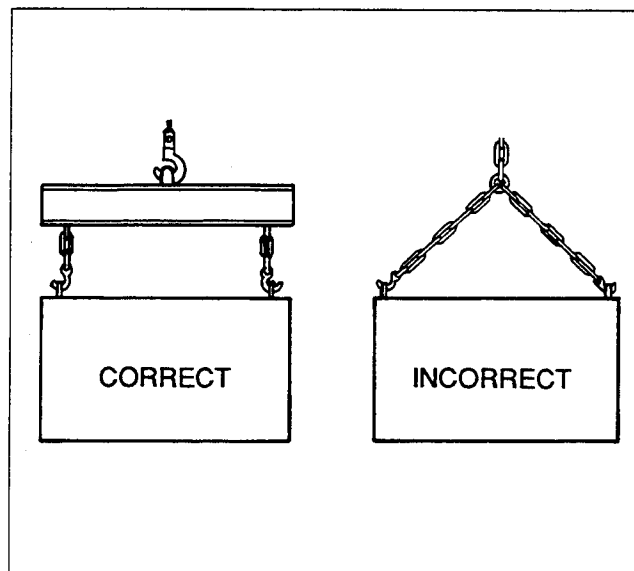

#### Forged eyebolt support

A Load - B Lifting shackle - C Shackle retaining plate (3 mm thick) - D Sleeve (may or may not be welded to plate)

In some cases, special lifting fixtures are available to obtain correct balance and provide for safe handling. Consult the relevant section of the Workshop Manual.

#### Warning

If a part resists removal, check that all nuts and bolts have been removed and that there is no interference from adjacent parts.



1A01.20

## 6100 SERIES TRACTORS



# Introduction

### Cleanliness

To ensure long life of a machine, it is important to keep dirt and foreign material out of its vital working components. Precautions must be taken to safeguard against this. Enclosed compartments, seals and filters have been provided to keep the supply of air, fuel and lubricant clean. These protective devices must not be removed.

Whenever hydraulic fluid, fuel, lubricating oil or air lines are disconnected, clean the point of disconnection and the surrounding area. As soon as a line has been disconnected, cap, plug or tape the line or opening to prevent the ingress of foreign material.

The same cleaning and covering precautions should be taken when access covers or inspection plates are removed.

Clean and inspect all parts. Make sure that all passages and holes are clear. Cover all parts to keep them clean. Make sure parts are clean when they are reassembled. Leave new parts in their wrapping until they are actually needed for reassembly.

### Assembly

When reassembling a machine, complete each step in sequence. Never partially assemble one part then start to assemble another. Make all recommended adjustments. Always check the job on completion to ensure that nothing has been overlooked.

Recheck the various adjustments before putting the machine back into service

*Note : Before fitting new parts, remove rust preventative compound from all machined surfaces (usually «peel-off» substances).*

### Lubrication

Where applicable, fill the compartments of repaired or renewed components with the quantity, type and grade of clean lubricant recommended in the routine maintenance section of the Operation Instruction Book.

### Shims

When shims are removed, tie them together and identify their location. Keep shims clean and take care not to bend them before refitting them.

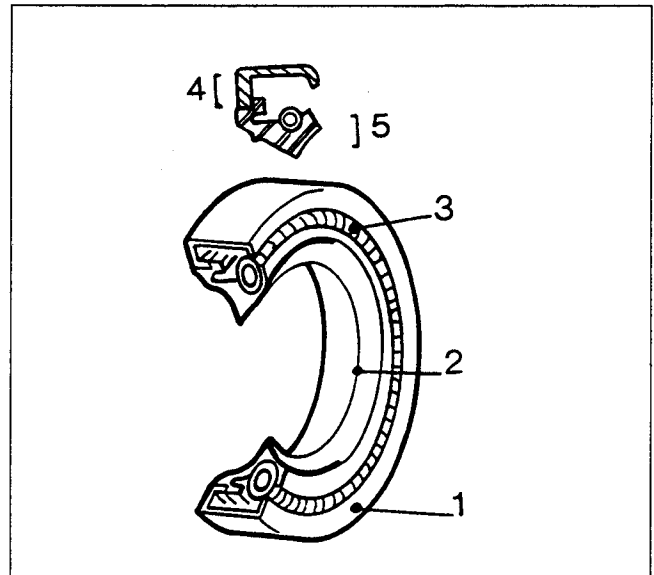

### Gaskets

Make sure that the holes in gaskets line up with lubricating oil passages in the mating parts. If gaskets have to be made, use material of the correct type and thickness. Make sure that holes are punched in the right places.

Incorrectly punched gaskets can cause serious damage.

### Lip type rubber seals.

Lubricate the lips of lip-type seals with oil before fitment. Do not use grease on seals, except for grease seals. The main parts of a lip-type seal are the case (1), the sealing element (2) and the ring spring (3). The figure shows the construction of a simple lip-type seal. The cross section shows the «heel» (4) and the «toe» (5), used to identify the sides of a single element seal. With a few exceptions, the toe of a single-lip seal is located on the lubricant side. Some seals have a second auxiliary lip which has no spring.



## Introduction

### Cables and wires

When removing or disconnecting a group of cables or wires, each one should be identified and labelled in order to ensure that they are correctly refitted.

### Nut and bolt locking devices

The loosening of nuts and bolts is prevented by using lockwashers, tab washers and cotter pins. In addition to these mechanical means, locking agents of the Loctite type are also used.

Flat retainers must be correctly installed in order to be effective. Bend one end of the retainer against the edge of the part. Bend the other end against one of the flats on the nut or bolt head.

Always fit new retainers in compartments which house moving parts. When fitting lockwashers on aluminium housing, place a flat washer between the lockwasher and the housing.

### Lubrication bushes and press fits

Bushes must never be fitted with a hammer alone. Use a suitable fitting tool and a hammer or, better still, a press if possible.

When using a press, ensure that pressure is applied directly in line with the bore. When a lubrication bush has an oil hole, that hole should be aligned with the hole in the mating part.

When press fitting a part into another part, lubricate the mating surfaces. Tapered parts should be assembled dry. Before assembly, check that the tapers are dry, clean and free from burrs.

### Fitting bolts in blind holes

Use bolts of the correct length. A bolt which is too long may "bottom" before the head comes into contact with the part it is intended to hold. This will cause damage to the threads.

If a bolt is too short, there may not be enough threads engaged to hold the part securely, and the bolt is therefore ineffective.

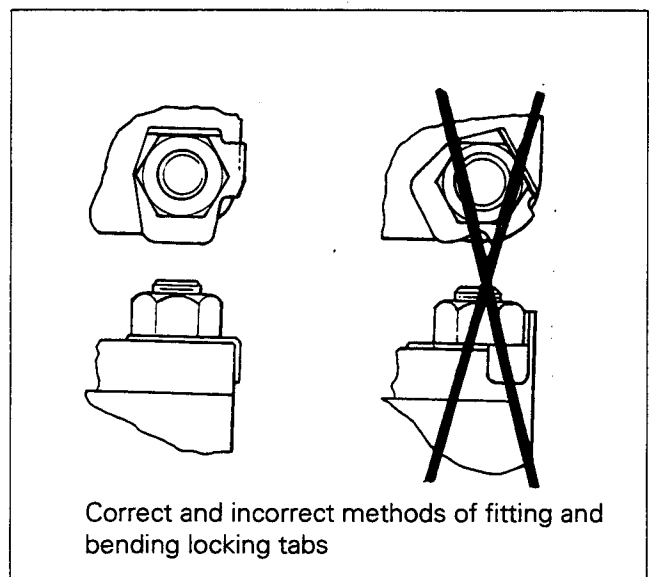
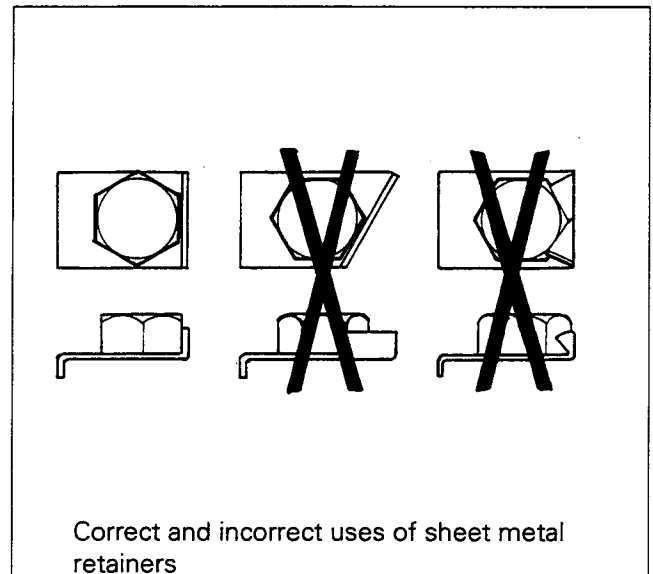





1A01.22



## Introduction

### F. Installation instructions

#### General

In order to ensure regular servicing of the tractor during the warranty period, the supplying MF Distributor or Dealer must carry out the 50-hour and 250-hour servicing operations.

The definition of this operation is designed to provide the tractor with maximum efficiency during the whole warranty period, thus ensuring that it gives reliable service after that period.

#### Pre-delivery check

The performance of the following operations must be ensured by the Distributor before delivery to a Dealer and by the Dealer before delivery to an owner or operator.

#### 1. General installation

- Clean the tops of batteries and smear the terminals with petroleum jelly.
- Charge the batteries, if necessary.
- Check all electrical connections, and cable, ducting and light attachments.
- Check and top up the oil levels in the engine and transmission housings.
- Lubricate all grease points.
- Check and adjust belt tensions, as required (alternator, fan, auxiliary pump and air-conditioning compressor).
- Unless it contains an antifreeze compound, flush the cooling system and refill with soft water.
- Check that the fuel tank contains enough fuel of the correct type.
- Check that the cylinder head attaching nuts and bolts are tightened to the required torque. Check that the inlet pipe and exhaust manifold attaching nuts and bolts are correctly tightened.
- Check and adjust the clearance between the valves and rockers and visually check the valve springs.
- Check the injectors, bleed the fuel system and tighten all fuel line connections.
- Check that the engine air filter hoses are secure.
- Check that the engine control linkages are correctly adjusted and operate freely.
- Start the engine.
- Check that the instruments and warning lights operate correctly.
- Check the engine speed on the tachometer with both the hand and foot-operated throttles.
- Hitch up a mounted implement and check that the tractor's hydraulic accessories operate correctly.
- Check and adjust the tyre pressures (road or field work).

- Check the tightness of all nuts, bolts, studs, pipe unions and attachment fittings.
- Check all pipes and hoses for leaks.
- Check that the headlights are correctly adjusted.
- Road test the tractor, checking the correct operation of the brakes and all instruments and accessories.

#### 2. Electronic systems

- Check that the electronic lifting system operates correctly. Carry out the quick check procedure described in section 11D01.
- Check all the Autotronic functions, following the test procedure in section 12B01.
- Check the on-board computer installation in accordance with procedure 13A01.

#### 3. Tightening torques

- Check the tightening torque on the attaching nuts and bolts on the various chassis attachment points:
  - Front axle/engine,
  - Engine/gearbox,
  - Gearbox/rear axle
  - Trumpet sections/rear axle.
- Check the tightening torque of the attaching nuts and bolts on wheels and wheel bodies.



## Introduction

### Instructions to driver

Instructions on items listed below must be given to the owner or operator.

1. Safety precautions when starting the engine.
2. Location and significance of tractor and engine serial numbers.
3. Controls and instruments.
4. Running-in.
5. Starting and stopping the engine.
6. Selection of gears and use of gearshift and reverse shuttle levers.
7. Danger of towing down the hill without engine braking and correct use of gearbox.
8. Use and adjustment of brakes and brake pedal latch.
9. Use of the vehicle's clutch.
10. Use of the hydraulic differential lock device.
11. Use of the hydraulic PTO - Clutch and brake.
12. Operation of hydraulic lift system.
13. Hitching and unhitching of towed implements.
14. Grease points.
15. Changing of oil grades.
16. Replacement of engine and transmission filter elements.
17. Operation of fuel system - Bleeding of fuel and injection system - Air filter - Clogging indicator.
18. Cooling system. Frost precautions. Tension of both fan belts.
19. Maintenance of electrical equipment (batteries). System with negative earth.
20. Adjustment of front and rear track.
21. Tyre pressures.
22. Tightness of nuts, bolts and screws.
23. Fuel storage and handling.
24. Use of auxiliary hydraulic equipment.
25. Filling in of tractor and engine serial numbers in the operator instruction book.
26. Reading of the operator instruction book.

## G. Conversion tables

### Pressure units

1 PSI = 1 lbf/in<sup>2</sup> = 0.0689 bar

1 bar = 14.512 lbf/in<sup>2</sup> = 14.512 PSI

Bar	lbf / in <sup>2</sup>	Bar	lbf / in <sup>2</sup>	Bar	lbf / in <sup>2</sup>
0.5	7.256	9.5	137.9	35	508
1	14.51	10	145	40	588
1.5	21.77	11	159.6	45	653
2	29	12	174	50	726
2.5	36.28	13	189	60	871
3	43.54	14	203	70	1029
3.5	50.8	15	218	80	1161
4	58	16	232	90	1306
4.5	65.3	17	247	100	1451
5	72.6	18	261	200	2903
5.5	79.8	19	276	300	4354
6	87.1	20	290	400	5805
6.5	94.3	21	309	500	7257
7	101.6	22	319	600	8708
7.5	108.8	23	334	700	10160
8	116.1	24	348	800	11611
8.5	123.4	25	368	900	13235
9	130.6	30	435	1000	14514



1A01.24

# 6100 SERIES TRACTORS



## Introduction

### Torque units

1 Nm = 0.7376 lbf/ft

1 lbf/ft = 1.3558 Nm

Nm		lbf/ft	Nm		lbf/ft	Nm		lbf/ft
1.3558	1	0.7376	46.0972	34	25.0784	90.8396	67	49.4912
2.7116	2	1.4752	47.4530	35	25.8160	92.1944	68	50.1568
4.0674	3	2.2128	48.8088	36	26.5536	93.5502	69	50.8944
5.4232	4	2.9504	50.1646	37	27.2912	94.9060	70	51.6320
6.7790	5	3.6880	51.5204	38	28.0288	96.2618	71	52.3696
8.1348	6	4.4256	52.8762	39	28.7664	97.6176	72	53.1072
9.4906	7	5.1632	54.2320	40	29.5040	98.9734	73	53.8448
10.8464	8	5.9008	55.5878	41	30.2416	100.329	74	54.5824
12.2022	9	6.6384	56.9436	42	30.9792	101.685	75	55.3200
13.5580	10	7.3760	58.2994	43	31.7168	103.041	76	56.0576
14.9138	11	8.1136	59.6552	44	32.4544	104.397	77	56.7952
16.2696	12	8.8512	61.0110	45	33.1920	105.752	78	57.5328
17.6254	13	9.5888	62.3668	46	33.9296	107.108	79	58.2704
18.9812	14	10.3264	63.7226	47	34.6672	108.464	80	59.0080
20.3370	15	11.0640	65.0784	48	35.4048	109.820	81	59.7456
21.6928	16	11.8016	66.4342	49	36.1424	111.176	82	60.4832
23.0486	17	12.5392	67.7900	50	36.8800	112.531	83	61.2208
24.4044	18	13.2768	69.1458	51	37.6176	113.887	84	61.9584
25.7602	19	14.0144	70.5016	52	38.3552	115.243	85	62.6960
27.1160	20	14.7520	71.8574	53	39.0928	116.600	86	63.4336
28.4718	21	15.4896	73.2132	54	39.8304	117.955	87	64.1712
29.8276	22	16.2272	74.5690	55	40.5680	119.310	88	64.9088
31.1834	23	16.9648	75.9248	56	41.3056	120.666	89	65.6464
32.5392	24	17.7024	77.2806	57	42.0432	122.022	90	66.3840
33.8950	25	18.4400	78.6364	58	42.7808	123.378	91	67.1216
35.2508	26	19.1776	79.9922	59	43.5184	124.734	92	67.8592
36.6066	27	19.9152	81.3480	60	44.2560	126.089	93	68.5968
37.9624	28	20.6528	82.7038	61	44.9936	127.445	94	69.3344
39.3182	29	21.3904	84.0596	62	45.7312	128.801	95	70.0720
40.6740	30	22.1280	85.4154	63	46.4688	130.157	96	70.8096
42.0298	31	22.8656	86.7712	64	47.2064	131.513	97	71.5472
43.3856	32	23.6032	88.1270	65	47.9440	132.868	98	72.2848
44.7414	33	24.3408	89.4828	66	48.6816	134.224	99	73.0224

### VISIBLE-RESULTS



# 6100 SERIES TRACTORS



1A01.25

## Introduction

### Capacity units

1 litre = 0.2199 imp. gallon

1 imp. gallon = 4.5459 litres

### Note:

1 US gallon = 3.79 litres

Imp. gal.		Litres	Imp. gal.		Litres	Imp. gal.		Litres
0.2199	1	4.5459	7.4766	34	154.561	14.733	67	304.575
0.4398	2	9.0918	7.6965	35	159.107	14.9532	68	309.121
0.6597	3	13.6377	7.9164	36	163.652	15.1731	69	313.667
0.8796	4	18.1836	8.1363	37	168.198	15.3930	70	318.213
1.0995	5	22.7295	8.3562	38	172.744	15.6129	71	322.759
1.3194	6	27.2754	8.5761	39	177.290	15.8328	72	327.305
1.5393	7	31.8213	8.7960	40	181.836	16.0527	73	331.851
1.7592	8	36.3672	9.0159	41	186.382	16.2726	74	336.397
1.9791	9	40.9131	9.2358	42	190.929	16.4925	75	340.943
2.1990	10	45.4590	9.4557	43	195.474	16.7124	76	345.488
2.4189	11	50.0049	9.6756	44	200.019	16.9323	77	350.034
2.6388	12	54.5508	9.8955	45	204.566	17.1522	78	354.580
2.8587	13	59.0967	10.1154	46	209.111	17.3721	79	359.126
3.0786	14	63.6426	10.3353	47	213.657	17.5920	80	363.672
3.2985	15	68.1885	10.5552	48	218.203	17.8119	81	368.218
3.5184	16	72.7344	10.7751	49	222.749	18.0318	82	372.764
3.7383	17	77.2803	10.9950	50	227.295	18.2517	83	377.310
3.9582	18	81.8262	11.2149	51	231.841	18.4716	84	381.856
4.1781	19	86.3721	11.4348	52	236.387	18.6915	85	386.402
4.3980	20	90.9180	11.6547	53	240.933	18.9114	86	390.947
4.6179	21	95.4639	11.8746	54	245.479	19.1313	87	395.493
4.8378	22	100.009	12.0945	55	250.025	19.3512	88	400.039
5.0577	23	104.556	12.3144	56	254.570	19.5711	89	404.585
5.2776	24	109.102	12.5343	57	259.116	19.7910	90	409.131
5.4975	25	113.648	12.7542	58	263.662	20.0109	91	413.677
5.7174	26	118.193	12.9741	59	268.209	20.2308	92	418.223
5.9373	27	122.739	13.1940	60	272.754	20.4507	93	422.769
6.1572	28	127.285	13.4139	61	277.299	20.6706	94	427.315
6.3771	29	131.831	13.6338	62	281.846	20.8905	95	431.861
6.5970	30	136.377	13.8537	63	286.392	21.1104	96	436.406
6.8169	31	140.923	14.0736	64	290.938	21.3303	97	440.952
7.0368	32	145.469	14.2935	65	295.483	21.5502	98	445.498
7.2567	33	150.015	14.5134	66	300.029	21.7701	99	450.044



1A01.26

Introduction

Capacity units

1 litre = 1.7599 imp. pints

1 imp. pint = 0.5682 litre

Note:

1 litre = 2.113 US pints

Imp. pt.		Litres	Imp. pt.		Litres	Imp. pt.		Litres
1.7599	1	0.5682	59.8366	34	19.3188	117.913	67	38.0694
3.5198	2	1.1364	61.5965	35	19.8870	119.673	68	38.6376
5.2797	3	1.7046	63.3564	36	20.4552	121.433	69	39.2058
7.0396	4	2.2728	65.1163	37	21.0234	123.193	70	39.7740
8.7995	5	2.8400	66.8762	38	21.5916	124.953	71	40.3422
10.5594	6	3.4902	68.6361	39	22.1598	126.713	72	40.9104
12.3193	7	3.9774	70.3960	40	22.7280	128.473	73	41.4786
14.0792	8	4.5456	72.1559	41	23.2962	130.233	74	42.0468
15.8391	9	5.1138	73.9158	42	23.8644	131.993	75	42.6150
17.5990	10	5.6820	75.6757	43	24.4326	133.752	76	43.1832
19.3589	11	6.2502	77.4356	44	25.0008	135.512	77	43.7514
21.1188	12	6.8184	79.1955	45	25.5690	137.272	78	44.3196
22.8787	13	7.3866	80.9554	46	26.1372	139.032	79	44.8878
24.6386	14	7.9548	82.7153	47	26.7054	140.792	80	45.4560
26.3985	15	8.5230	84.4752	48	27.2736	142.552	81	46.0242
28.1854	16	9.0912	86.2351	49	27.8418	144.312	82	46.5924
29.9183	17	9.6594	87.9950	50	28.4100	146.072	83	47.1606
31.6782	18	10.2276	89.7549	51	28.9782	147.832	84	47.7288
33.4381	19	10.7958	91.5148	52	29.5464	149.592	85	48.2970
35.1980	20	11.3640	93.2747	53	30.1146	151.351	86	48.8652
36.9579	21	11.9322	95.0346	54	30.6828	153.111	87	49.4334
38.7178	22	12.5004	96.7945	55	31.2510	154.871	88	50.0016
40.4770	23	13.0686	98.5544	56	31.8192	156.631	89	50.5698
42.2376	24	13.6368	100.314	57	32.3874	158.391	90	51.1380
43.9975	25	14.2050	102.074	58	32.9556	160.151	91	51.7062
45.7574	26	14.7732	103.834	59	33.5238	161.912	92	52.2744
57.5173	27	15.3414	105.594	60	34.0920	163.671	93	52.8426
49.2772	28	15.9096	107.354	61	34.6602	165.431	94	53.4108
51.0371	29	16.4778	109.114	62	35.2284	167.191	95	53.9790
52.7970	30	17.0460	110.874	63	35.7966	168.950	96	54.5472
54.5569	31	17.6142	112.634	64	36.3648	170.710	97	55.1154
56.3168	32	18.1824	114.394	65	36.9330	172.470	98	55.6836
58.0767	33	18.7506	116.153	66	37.5012	174.230	99	56.2518

VISIBLE-RESULTS

**Introduction****Length units**

1 m = 3.2808 ft

1 ft = 0.3048 m

m		ft	m		ft	m		ft
0.3048	1	3.2808	10.3632	34	111.549	20.4216	67	219.816
0.6096	2	6.5617	10.6680	35	114.829	20.7264	68	223.097
0.9144	3	9.8425	10.9728	36	118.110	21.0312	69	226.378
1.2192	4	13.1234	11.2776	37	121.391	21.3360	70	229.659
1.5240	5	16.4042	11.5824	38	124.672	21.6408	71	232.940
1.8288	6	19.6850	11.8872	39	127.953	21.9456	72	236.220
2.1336	7	22.9659	12.1920	40	131.234	22.2504	73	239.501
2.4384	8	26.2467	12.4968	41	134.514	22.5552	74	242.782
2.7432	9	29.5276	12.8016	42	137.795	22.8600	75	246.063
3.0480	10	32.8084	13.1064	43	141.076	23.1648	76	249.344
3.3528	11	36.0892	13.4112	44	144.357	23.4696	77	252.625
3.6576	12	39.3701	13.7160	45	147.638	23.7744	78	255.906
3.9624	13	42.6509	14.0208	46	150.919	24.0792	79	259.186
4.2672	14	45.9318	14.3256	47	154.199	24.3840	80	262.467
4.5720	15	49.2126	14.6304	48	157.480	24.6888	81	265.748
4.8768	16	52.4934	14.9352	49	160.761	24.9936	82	269.029
5.1816	17	55.7743	15.2400	50	164.042	25.2984	83	272.310
5.4864	18	59.0551	15.5448	51	167.323	25.6032	84	275.591
5.7912	19	62.3360	15.8496	52	170.604	25.9080	85	278.871
6.0960	20	65.6168	16.1544	53	173.885	26.2128	86	282.152
6.4008	21	68.8976	16.4592	54	177.165	26.5176	87	285.433
6.7056	22	72.1785	16.7640	55	180.446	26.8224	88	288.714
7.0104	23	75.4593	17.0688	56	183.727	27.1272	89	291.995
7.3152	24	78.7402	17.3736	57	187.008	27.4320	90	295.276
7.6200	25	82.0210	17.6784	58	190.289	27.7368	91	298.556
7.9248	26	85.3018	17.9832	59	193.570	28.0416	92	301.837
8.2296	27	88.5827	18.2880	60	196.850	28.3464	93	305.118
8.5344	28	91.8635	18.5928	61	200.131	28.6512	94	308.399
8.8392	29	95.1444	18.8976	61	203.412	28.9560	95	311.680
9.1440	30	98.4252	19.2024	63	206.693	29.2608	96	314.961
9.4488	31	101.7060	19.5072	64	209.974	29.5656	97	318.241
9.7536	32	104.9870	19.8120	65	213.255	29.8704	98	321.522
10.0584	33	108.2680	20.1168	66	216.535	30.1752	99	324.803



1A01.28

# 6100 SERIES TRACTORS



## Introduction

### Weight units

1 kg = 2.2046 lb

1 lb = 0.4536 kg

kg		lb	kg		lb	kg		lb
0.4536	1	2.2046	15.4224	34	74.9564	30.3912	67	147.708
0.9072	2	4.4092	15.8760	35	77.1610	30.8448	68	149.913
1.3608	3	6.6138	16.3296	36	79.3656	31.2984	69	152.117
1.8144	4	8.8184	16.7832	37	81.5702	31.7520	70	154.322
2.2680	5	11.0230	17.2368	38	83.7748	32.2056	71	156.527
2.7216	6	13.2276	17.6904	39	85.9794	32.6592	72	158.731
3.1752	7	15.4322	18.1440	40	88.1840	33.1128	73	160.936
3.6288	8	17.6368	18.5976	41	90.3886	33.5664	74	163.140
4.0824	9	19.8414	19.0512	42	92.5932	34.0200	75	165.345
4.5360	10	22.0460	19.5048	43	94.7978	34.4736	76	167.549
4.9896	11	24.2506	19.9584	44	97.0024	34.9272	77	169.754
5.4432	12	26.4552	20.4120	45	99.207	35.3808	78	171.958
5.8968	13	28.6598	20.8656	46	101.412	35.8344	79	174.163
6.3504	14	30.8644	21.3192	47	103.616	36.2880	80	176.368
6.8040	15	33.0690	21.7728	48	105.821	36.7416	81	178.573
7.2576	16	35.2736	22.2264	49	108.025	37.1952	82	180.777
7.7112	17	37.4782	22.6800	50	110.230	37.6488	83	182.982
8.1648	18	39.6828	23.1336	51	112.435	38.1024	84	185.186
8.6184	19	41.8874	23.5872	52	114.639	38.5560	85	187.391
9.0720	20	44.0920	24.0408	53	116.844	39.0096	86	189.596
9.5256	21	46.2966	24.4944	54	119.048	39.4632	87	191.800
9.9792	22	48.5012	24.9489	55	121.253	39.9168	88	194.005
10.4328	23	50.7058	25.4016	56	123.458	40.3704	89	196.209
10.8864	24	52.9104	25.8552	57	125.662	40.8240	90	198.414
11.3400	25	55.1150	26.3088	58	127.867	41.2776	91	200.619
11.7936	26	57.3196	26.7624	59	130.071	41.7312	92	202.823
12.2472	27	59.5242	27.2160	60	132.276	42.1848	93	205.028
12.7008	28	61.7288	27.6696	61	134.481	42.6384	94	207.232
13.1544	29	63.9334	28.1232	62	136.685	43.0920	95	209.437
13.6080	30	66.1380	28.5768	63	138.889	43.5456	96	211.642
14.0616	31	68.3426	29.0304	64	141.094	43.9992	97	213.846
14.5152	32	70.5472	29.4840	65	143.299	44.4528	98	216.051
16.9688	33	72.7518	29.9376	66	145.504	44.9064	99	218.255

VISIBLE-RESULTS

**Introduction****Conversion table**

Fractions of inches	LENGTHS 1 inch = 25.4 mm						TEMPERATURE			
	Decimals	mm	Inches to mm		mm to inches		Fahrenheit to Celsius			
			Inches	mm	mm	Inches	° F	° C	° C	° F
1/64	.015625	0.3969					- 20	- 28.9	- 30	- 22
1/32	.031250	0.7937					- 15	- 26.1	- 28	- 18.4
3/64	.468750	1.1906					- 10	- 23.3	- 26	- 14.8
1/16	.062500	1.5875	0.0001	0.00254	0.004	0.00015	- 5	- 20.6	- 24	- 11.2
5/64	.078125	1.9844	.0002	.00508	0.005	.00019	0	- 17.8	- 22	- 7.6
3/32	.093750	2.3812	.0003	.00762	0.006	.00023	1	- 17.2	- 20	- 4
7/64	.109375	2.7781	.0004	.01016	0.007	.00027	2	- 16.7	- 18	- 0.4
1/8	.125000	3.1750	.0005	.01270	0.008	.00031	3	- 16.1	- 16	3.2
9/64	.140625	3.5719	.0006	.01524	0.009	.00035	4	- 15.6	- 14	6.8
5/32	.156250	3.9687	.0007	.01778	0.01	.00039	5	- 15.0	- 12	10.4
11/64	.171875	4.3656	.0008	.02032	0.02	.00079	10	- 12.2	- 10	14
3/16	.187500	4.7625	.0009	.02286	0.03	.00118	15	- 9.4	- 8	17.6
13/64	.203125	5.1594	.001	.0254	0.04	.00157	20	- 6.7	- 6	21.2
7/32	.218750	5.5562	.002	.0508	0.05	.00197	25	- 3.9	- 4	24.8
15/64	.234375	5.9531	.003	.0762	0.06	.00236	30	- 1.1	- 2	28.4
1/4	.250000	6.3500	.004	.1016	0.07	.00276	35	1.7	0	32
17/64	.265625	6.7469	.005	.1270	0.08	.00315	40	4.4	2	35.6
9/32	.281250	7.1437	.006	.1524	0.09	.00354	45	7.2	4	39.2
19/64	.296875	7.5406	.007	.1778	0.10	.00394	50	10.0	6	42.8
5/16	.312500	7.9375	.008	.2032	0.20	.0078	55	12.8	8	46.4
21/64	.328125	8.3344	.009	.2286	0.30	.01181	60	15.6	10	50
11/32	.343750	8.7312	.01	.254	0.40	.01575	65	18.3	12	53.6
23/64	.359375	9.1281	.02	.508	0.50	.01969	70	21.1	14	57.2
3/8	.375000	9.5250	.03	.762	0.60	.02362	75	23.9	16	60.8
25/64	.390625	9.9219	.04	1.016	0.70	.02756	80	26.7	18	64.4
13/32	.406250	10.3187	.05	1.270	0.80	.03149	85	29.4	20	68
27/64	.421875	10.7156	.06	1.524	0.90	.03543	90	32.2	22	71.6
7/16	.437500	11.1125	.07	1.778	1	.03937	95	35.0	24	75.2
29/64	.453125	11.5094	.08	2.032	2	.07874	100	37.8	26	78.8
15.32	.468750	11.9062	.09	2.286	3	.11811	105	40.6	28	82.4
31/64	.484375	12.3031	.10	2.540	4	.15748	110	43.3	30	86
1/2	.500000	12.7000	.20	5.080	5	.19685	115	46.1	32	89.6
33/64	.515625	13.0969	.30	7.620	6	.23622	120	48.9	34	93.2
17/32	.53125	13.4937	.40	10.160	7	.27559	125	51.7	36	96.8





1A01.30

**Introduction**

LENGTHS 1 inch = 25.4 mm							TEMPERATURE			
Fractions of inches	Decimals	mm	Inches to mm		mm to inches		Fahrenheit to Celsius			
			Inches	mm	mm	Inches	° F	° C	° C	° F
35/64	.546875	13.8906	0.5	12.70	8	0.31496	130	54.4	38	100.4
9/16	.562500	14.2875	.6	15.24	9	.35433	135	57.2	40	104
37/64	.578125	14.6844	.7	17.78	10	.39370	140	60.0	42	107.6
19/32	.593750	15.0812	.8	20.32	11	.43307	145	62.8	44	112.2
39/64	.609375	15.4781	.9	22.86	12	.47244	150	65.6	46	114.8
5/8	.6250	15.8750	1	25.4	13	.51181	155	68.3	48	118.4
41/64	.640625	16.2719	2	50.8	14	.55118	160	71.1	50	122
21/32	.656250	16.6687	3	76.2	15	.59055	165	73.9	52	125.6
43/64	.671875	17.0656	4	101.6	16	.62992	170	76.7	54	129.2
11/16	.687500	17.4625	5	127	17	.66929	175	79.4	56	132.8
45/64	.703125	17.8594	6	152.4	18	.70866	180	82.2	58	136.4
23/32	.718750	18.2562	7	177.8	19	.74803	185	85.0	60	140
47/64	.734375	18.6531	8	203.2	20	.78740	190	87.8	62	143.6
3/4	.7500	19.05	9	228.6	21	.82677	195	90.6	64	147.2
49/64	.765625	19.4469	10	254	22	.86614	200	93.3	66	150.8
25/32	.781250	19.8437	11	279.4	23	.90551	205	96.1	68	154.4
51/64	.796875	20.2406	12	304.8	24	.94480	210	98.9	70	158
13/16	.812500	20.6375	13	330.2	25	.98425	212	100.0	75	167
53/64	.828125	21.0344	14	355.6	26	1.02362	215	101.7	80	176
27/32	.843750	21.4312	15	381	27	1.06299	220	104.4	85	185
55/64	.859375	21.8281	16	406.4	28	1.10236	225	107.2	90	194
7/8	.875000	22.2250	17	431.8	29	1.14173	230	110.0	95	203
57/64	.890625	22.6219	18	457.2	30	1.18110	235	112.8	100	212
29/32	.906250	23.0187	19	482.6	31	1.22047	240	115.6	105	221
59/64	.921875	23.4156	20	508	32	1.25984	245	118.3	110	230
15/16	.937500	23.8125	21	533.4	33	1.29921	250	121.1	115	239
61/64	.953125	24.2094	22	558.8	34	1.33858				
31/32	.968750	24.6062	23	584.2	34	1.37795				
63/64	.984375	25.0031	24	609.6	36	1.41732				
1	1.00	25.40	25	635	37	1.45669				
			26	660.4	38	1.49606				
					39	1.53543				
					40	1.57480				

**VISIBLE-RESULTS**



## Introduction

### H. Locking compounds and sealants

The Loctite compounds mentioned in this manual are referred to by their industrial names.

For the purposes of repairs, use their commercial names or the corresponding MF references as per the following chart.

Loctite industrial name	Commercial	MF reference
242 - 241 - 542	Lock and Seal	1 633 266 M1
270	Stud lock	1 633 267 M1
510 - 221	Instant Gasket Retainer	1 633 270 M2
638 - 648	Superflex sealant.	1 633 268 M1
Silicomet	R.T.V. silicone sealant (clear)	3 405 423 M1

**Note: Use the product "Form A gasket 2" when sealing between plastic material and iron (or steel).**

**Examples: PTO sensor, vehicle speed sensor, etc..**

These products can be ordered from the following address:

FRAMET

10 Avenue Eugène Gazeau

Zone Industrielle

60304 - SENLIS

FRANCE

### Application method for Loctite products

- Remove all traces of previous sealants and corrosion
  - by mechanical process: wire brush or emery cloth,
  - by chemical action: "DECAPLOC 88".
 Leave the product to take effect and then wipe clean.
- Degrease the components with dry solvent
  - preferably, use "LOCTITE 706 Dry Super Solvent".
- Allow the solvents to evaporate.
- Apply the recommended type of LOCTITE sealant on the parts:
  - For blind tapped holes: apply a quantity of product on the last threads at the bottom of the hole.
  - For cylindrical fitting components, apply compound on both mating surfaces with a clean brush.

- For gasket faces, apply a bead on one of the two faces, passing around the holes, and then tighten as quickly as possible.

**Note:**

**a) Do not use too much of the compound in order to avoid locking adjacent parts.**

**b) Do not attempt to retighten after 5 minutes of curing in order to avoid breaking the film of compound.**

**c) If the ambient temperature is less than +10°C, and to ensure quicker setting of Loctite compounds (except for SILICOMET), use LOCTITE T 747 activator on at least one of the two parts.**

**Excess sealant outside the joint will not harden (anaerobic curing of compound - i.e. curing occurs only in absence of oxygen).**

### Grease

When grease is used in components which are in contact with transmission oil, use a grease which is miscible with oil to avoid clogging the hydraulic filters.

Use "Amber Technical" grease supplied by WITCO company, 76320 Saint-Pierre des Elfes, France.

### I. Tightening torques

When tightening nuts and bolts, use the recommended tightening torques as per the charts:

- **1** and **2** : for metric threads,
- **3** and **4** : for inch threads.

When a specific torque is required, it is mentioned in the text.

Charts 1 and 3 specify the standard tightening torque values applicable to zinc-plated threaded elements with standard nuts with coarse or fine thread, with or without flat washers or lockwashers, and weld nuts deeper than 0.8 d.

Charts 2 and 4 specify the reduced tightening torque values applicable to threaded fasteners in assemblies with self-locking zinc-plated nuts, phosphated nuts or bolts, shallow nuts and weld nuts shallower than 0.8 d.

These values are applicable to dry assemblies. If the threads are oiled, reduce the tightening torques.

**Note: Read the strength classification on the bolt head and determine the required torque loading.**

Example:

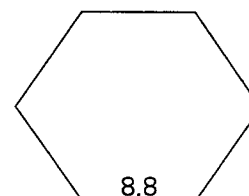



1A01.32

## 6100 SERIES TRACTORS

**Introduction****Chart 1**

Tightening torque values: zinc-plated metric threads

Nominal dimension d.	Strength classification		Strength classification	
	ISO 8.8 (SAE 5, BS S)		ISO 10.9 (SAE 8, BS V)	
	Torque Nm		Torque Nm	
	Max.	Min.	Max.	Min.
M3	1.7	1.3	2.4	1
M4	4.1	3.1	5.7	4
M5	8	6	11.5	8
M6	14	10	20	14
M8	35	25	46	36
M10	70	50	96	72
M12	120	90	160	120
M16	260	200	400	300
M20	560	420	800	600
M24	960	720	1300	1000
M30	1800	1400	2800	2100
M36	3300	2500	4800	3600

**Chart 2**

Reduced tightening torque values: metric threads

Nominal dimension d.	Strength classification		Strength classification	
	ISO 8.8 (SAE 5, BS S)		ISO 10.9 (SAE 8, BS V)	
	Torque Nm		Torque Nm	
	Max.	Min.	Max.	Min.
M3	1.4	1	1.9	1
M4	3.3	2.5	4.6	3
M5	6.4	4.8	9.2	6
M6	11	8	16	12
M8	28	20	37	29
M10	56	40	77	57
M12	96	72	130	100
M16	210	160	320	240
M20	450	340	640	480
M24	770	570	1040	800
M30	1400	1100	2200	1700
M36	2600	2000	3800	2900

**VISIBLE-RESULTS**

**Introduction****Chart 3**

Tightening torque values: zinc-plated threads in inches

Nominal dimension d.	Strength classification		Strength classification	
	SAE 5 (ISO 8.8 BS S)		SAE 8 (ISO 10.9 BS V)	
	Torque Nm		Torque Nm	
	Max.	Min.	Max.	Min.
#6	2.4	1.8	3.3	2
#8	4.4	3.4	6.3	4
#10	6.3	4.7	8.9	6
1/4	15	11	22	16
5/16	30	22	43	31
3/8	53	39	75	55
7/16	86	64	120	90
1/2	130	100	180	140
5/8	260	200	370	280
3/4	460	350	660	490
7/8	760	560	1060	800
1	1120	840	1600	1200
1 1/8	1390	1050	2200	1700
1 1/4	2000	1500	3200	2400
1 1/2	3400	2600	5400	4100

**Chart 4**

Reduced tightening torque values: zinc-plated threads in inches

Nominal dimension d.	Strength classification		Strength classification	
	SAE 5 (ISO 8.8 BS S)		SAE 8 (ISO 10.9 BS V)	
	Couple Nm		Couple Nm	
	Max.	Min.	Max.	Min.
#6	1.9	1.5	2.6	2
#8	3.5	2.7	5	3
#10	5	3.8	7.1	5
1/4	12	8.8	18	13
5/16	24	18	34	25
3/8	42	31	60	44
7/16	69	51	96	72
1/2	104	80	140	110
5/8	210	160	300	220
3/4	370	280	530	390
7/8	610	450	850	640
1	900	670	1280	960
1 1/8	1100	840	1760	1360
1 1/4	1600	1200	2560	1920
1 1/2	2700	2100	4320	3280





## **2 . SPLITTING THE TRACTOR**

### **Contents**

- 2 A01 SPLITTING THE TRACTOR BETWEEN THE ENGINE AND THE GEARBOX**
- 2 B01 SPLITTING THE TRACTOR BETWEEN THE GEARBOX AND THE REAR AXLE**
- 2C01 SPLITTING THE TRACTOR BETWEEN THE FRONT SUPPORT AND THE ENGINE**

**VISIBLE-RESULTS**



***Splitting the tractor - Engine / gearbox***

2A01.1

*2 A01 Splitting the tractor between the engine  
and the gearbox*

CONTENTS

<b>A. Uncoupling</b>	_____	<b>2</b>
<b>B. Recoupling</b>	_____	<b>3</b>
<b>C. Service tool</b>	_____	<b>4</b>





2A01.2

## 6100 SERIES TRACTORS



# Splitting the tractor - Engine / gearbox

### A. Uncoupling

1. Disconnect the two front differential lock (4WD) control hoses. Plug the pipe connections.
2. Remove the guard and the 4WD drive shaft.
3. Remove the sheet metal panels.
4. Disconnect the earth cables only from the batteries.
5. Remove the hood rear bracket.
6. Disconnect and plug:
  - the two Orbitrol steering ram hoses (and mark their position),
  - the two air conditioning connections using plugs No. 3376935M91 (Section C), (according to option fitted), and remove the bracket,
  - the diesel fuel return hose,
  - the two cooler hoses on the 17-bar valve (and mark their positions),
  - the accelerator control on the injection pump,
  - the flowmeter harness (if fitted),
  - the main wiring harness connections above the engine,
  - the heating hoses (plug the openings to avoid draining the cooling system completely),
  - the 7.5 A and 10 A fuse harness (to release this harness, slightly loosen the right-hand bar above the radiator),
  - the diesel fuel supply hose.
7. Immobilise the tractor:
  - apply the handbrake,
  - fit wedges between the frame and the front axle (Fig. 1).
8. Support the tractor under the gearbox using a stand.
9. Support the tractor under the sump using a stand.
10. Remove the toolbox and take out the two bolts (1) from the shock absorbers on the right-hand and left-hand cab supports. Slightly raise the cab and fit wedges (4-cylinder engine). (See Fig. 2).
11. Loosen the bolts attaching the engine to the gearbox.
12. Separate the gearbox from the engine.

**Note:** As a safety measure, remove the front weights.

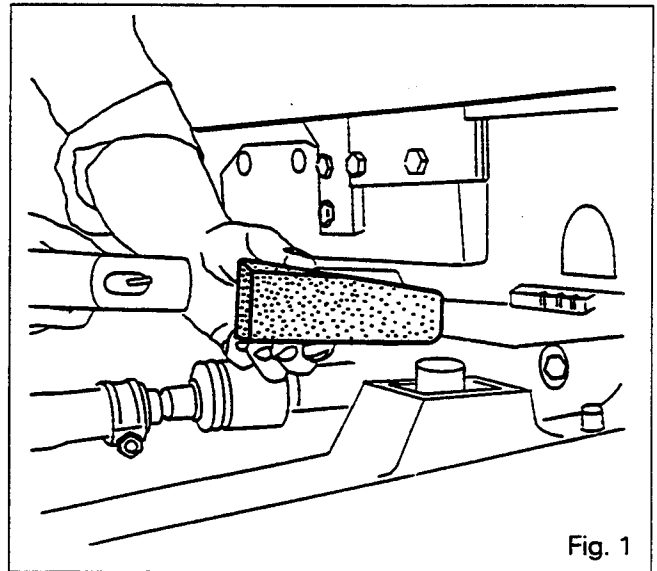

Fig. 1

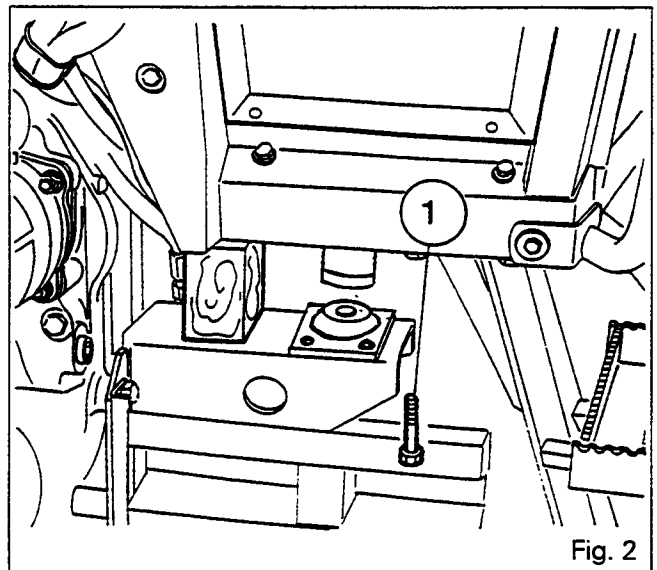

Fig. 2



## Splitting the tractor - Engine / gearbox

2A01.3

### B . Recoupling

**Note:** Tractors of types 6170 to 6180 from serial number F058049 onwards and 6190 tractors (pressure-loaded clutch) are equipped with a damper (6) (Fig. 3B) different from the one fitted on the version with a spring-loaded clutch (Fig. 3A).

13. Screw two dowels (locally manufactured) in diametrically opposite positions on the gearbox (except for 6150 series tractors).
14. Lightly grease the splines on the shaft (7) (Fig. 3A and 3B) (grease of type GN + Molykote) and slide the bush (9) onto the shaft as shown in Fig. 3A (tractor with spring-loaded clutch and spacer between engine and gearbox).
15. Check that the two locating pins are fitted on the engine.
16. Fit the engine to the gearbox by turning the flywheel ring gear with a screwdriver.
17. For 6-cylinder engines, smear the bolts with Loctite 270.  
Tighten the bolts (Figures 4 and 5):  
**4-cylinder engines**  
- 1 to 15: 100 to 130 Nm  
**6-cylinder engines**  
- 1 - 3 - 4 - 11 - 12: 120 to 160 Nm  
- 2 - 5 - 10 - 13 - 14 - 15: 300 to 400 Nm  
- 6 - 7 - 8 - 9: 600 to 800 Nm
18. Position the cab on its supports, making sure that the balls of the gear lever and reversing lever (if fitted) are correctly fitted in their respective bell housings. Fit the bolts (1) on the shock absorbers (Fig. 2) and tighten them to a torque of 200 to 270 Nm.
19. Carry out procedures 4 to 9 in reverse order.
20. Top up the radiator.
21. Refit the 4WD drive shaft and the guard, and reconnect the hoses for the differential lock control.
22. Reset the electric reverse shuttle control system (if fitted).
23. Check the accelerator control setting.
24. Check:
  - the hydraulic systems for leaks,
  - the correct operation of electrical circuits.
25. Reinstall the sheet metal panels.
26. Carry out road test.

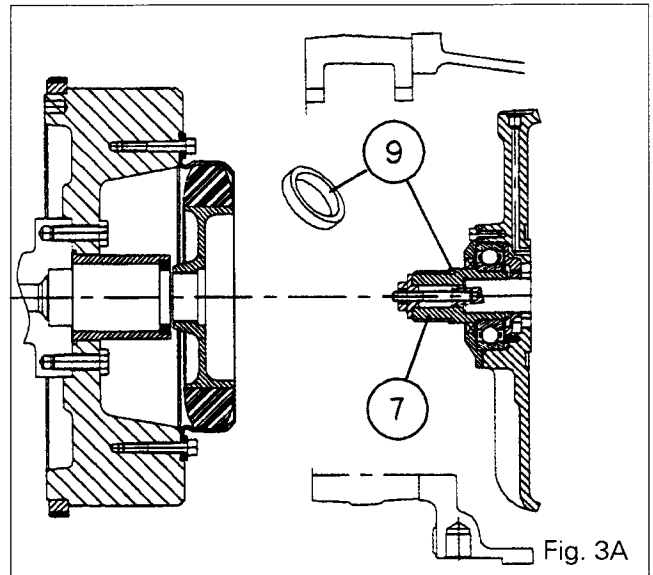

Fig. 3A

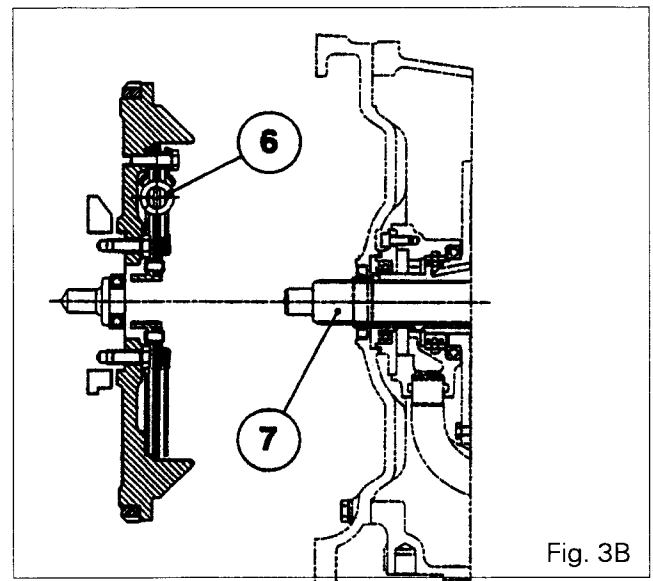

Fig. 3B

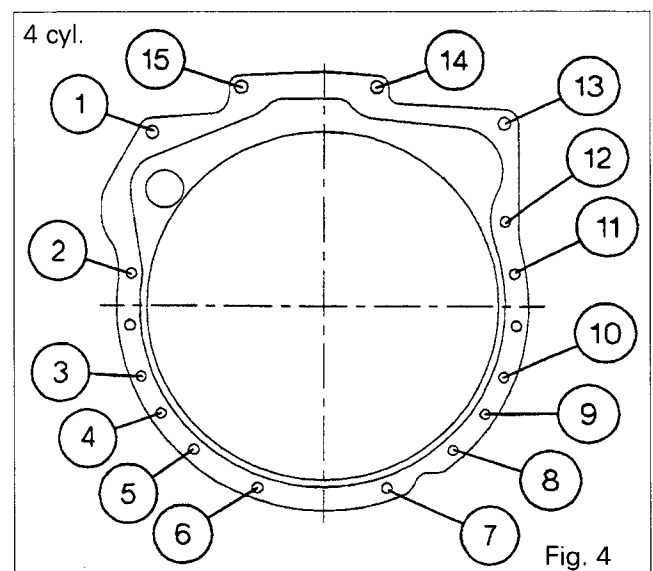

Fig. 4



2A01.4

## 6100 SERIES TRACTORS



# Splitting the tractor - Engine / gearbox

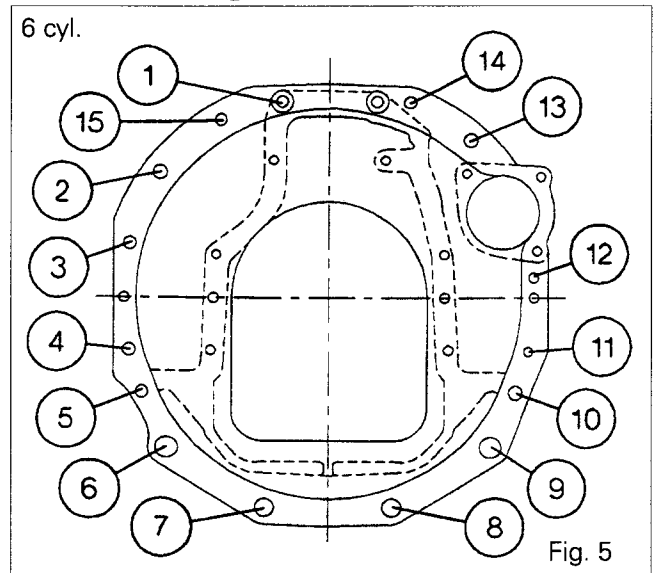

### C . Service tool

3376935M91 - Set of plugs for air conditioning couplings

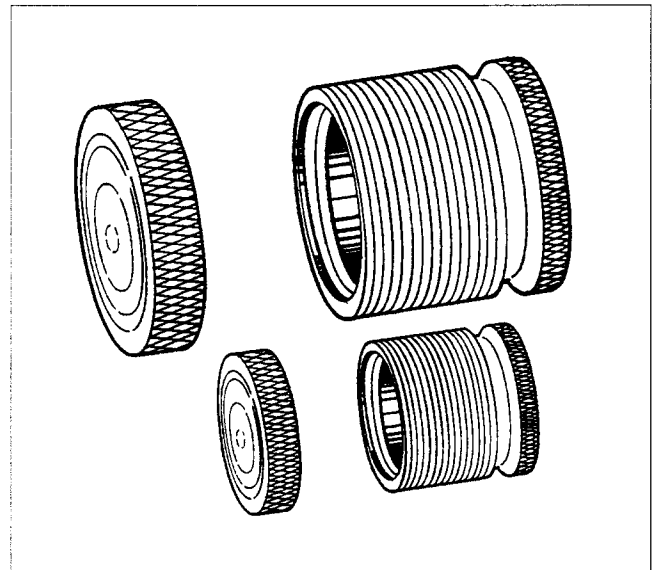

**VISIBLE-RESULTS**



***Splitting the tractor - Gearbox / rear axle***

2B01.1

*2 B01 Splitting the tractor between the gearbox  
and the rear axle (cab integral with rear axle)*

CONTENTS

A.	<b>Uncoupling</b> _____	2
B.	<b>Recoupling</b> _____	4
C.	<b>Service tool</b> _____	5



2B01.2

## 6100 SERIES TRACTORS



# Splitting the tractor - Gearbox / rear axle

### A. Uncoupling

1. Immobilise the tractor. Apply the handbrake. Fit wedges between the frame and the axle (Fig. 1).
2. Disconnect the front differential lock (4WD) control hoses and plug the pipe connections.
3. Remove the guard and the 4WD drive.
4. Remove the sheet metal panels and the exhaust pipe.
5. Disconnect the earth cables only from the batteries.
6. Remove the hood rear bracket.
7. Disconnect and plug:
  - the two Orbitrol steering ram hoses (and mark their position),
  - the two air conditioning connections using plugs No. 3376935M91 (Section C), (according to option fitted), and remove the bracket,
  - the diesel fuel return hose,
  - the two cooler hoses on the 17-bar valve (and mark their positions),
  - the accelerator control on the injection pump,
  - the flowmeter harness (if fitted),
  - the main wiring harness connections above the engine,
  - the diesel fuel supply hose,
  - the heating hoses.
8. Plug the openings to avoid draining the cooling system completely.
9. Drain the oil from the gearbox and the rear axle.
10. Disconnect and plug the following tubes or hoses:
  - the power take-off clutch lubricating tube,
  - the gearbox lubricating hose,
  - the return hose,
  - the engine clutch lubricating hose from the master cylinder to the control valve (pressure-loaded type) or to the gearbox (spring-loaded type).
11. Remove the earth braid from the right-hand cab support.
12. Remove the right-hand guard protecting the controls and solenoid valves.

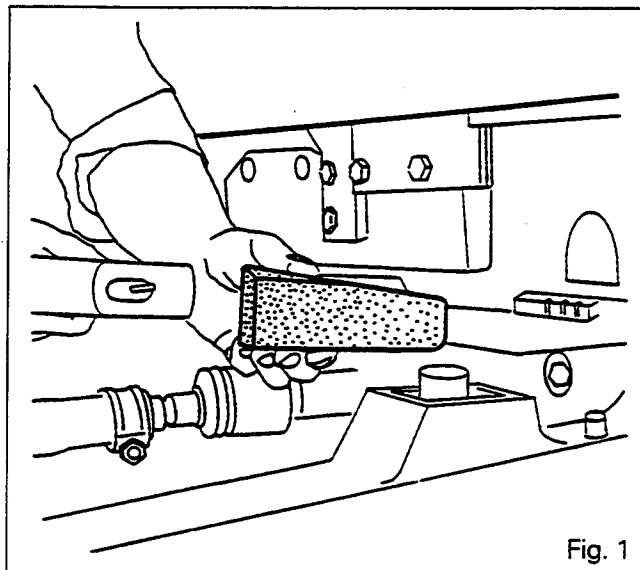

13. Disconnect:
  - the wire from the radar (Datatronic),
  - the harness on the solenoid valve or valves on the Speedshift or Dynashift unit (according to version),
  - the solenoid valves harness on the right-hand hydraulic cover (brake and clutch, PTO, differential lock, 4WD and Hare/Tortoise),
14. Remove the gear and reversing levers (if fitted) from the selector cover and remove the harnesses (earth, electrohydraulically controlled reverse shuttle solenoid valves (according to option), temperature probe (if fitted) and Hare/Tortoise).
15. Remove the main filter (15 micrometres).
16. Remove the engine clutch lubricating tube mounted on the lower covers of the centre housing and on the gearbox.



## Splitting the tractor - Gearbox / rear axle

17. Disconnect the creeper gear control (if fitted) and then remove the bolt (1) and pull the rod (2) towards the outside to release the finger from the fork (Fig. 2).
18. Place stands:
  - under the rear axle housing,
  - to the rear of the hitch hook,
  - to the rear of the gearbox.
19. Remove the bolts (1) from the right-hand and left-hand cab supports (Fig. 3). Raise the cab and fit wedges.
20. Loosen the bolts attaching the gearbox to the rear axle.
21. Separate the gearbox from the rear axle (Fig. 4).

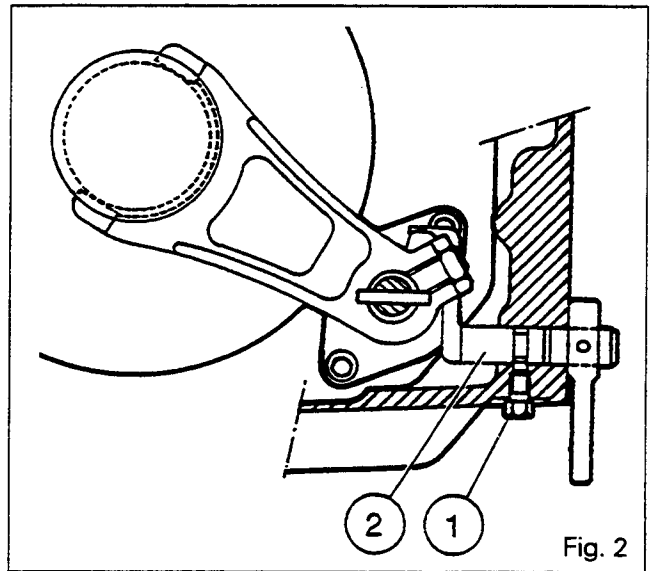

Fig. 2

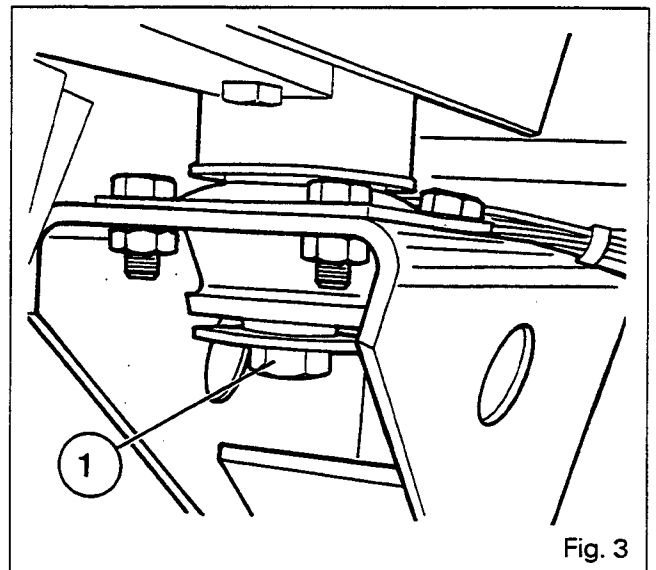

Fig. 3

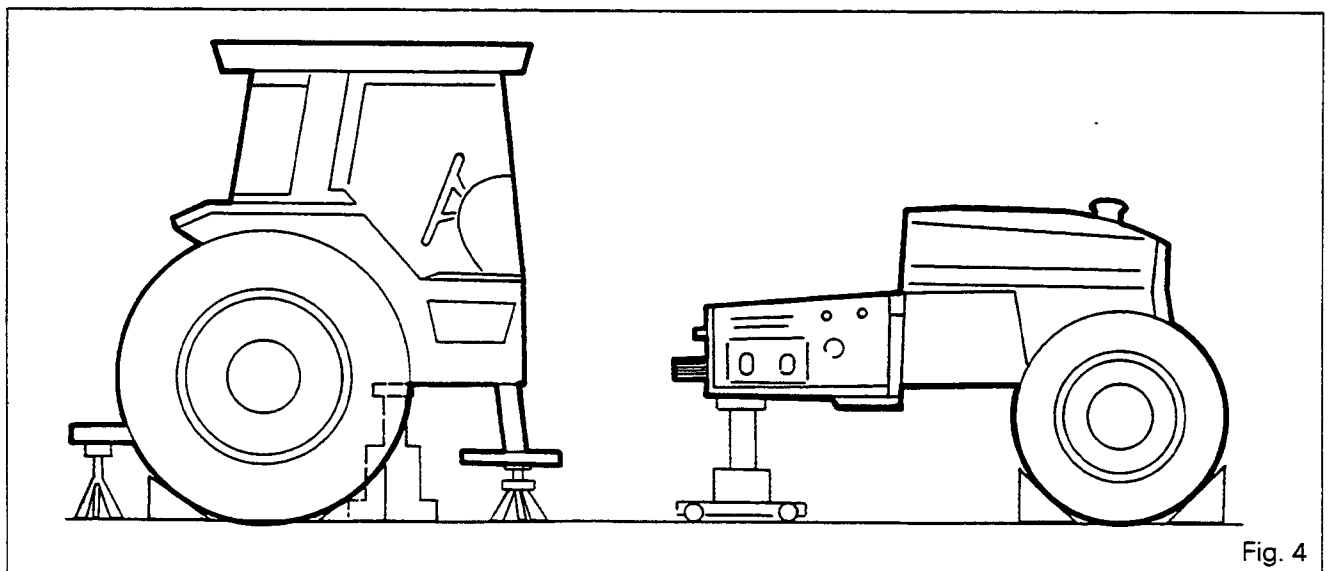

Fig. 4



2B01.4

# 6100 SERIES TRACTORS



## Splitting the tractor - Gearbox / rear axle

### B. Recoupling

22. Clean the mating faces on the gearbox and the rear axle housing.

#### On the rear axle

23. Position:

- the shaft (1) assembled with the sleeves (2) and (7) by means of double pins (5) and (6) (for gearbox without creeper gears) on the drive gear (3) (Fig. 5a),
- the shaft (1) assembled with the sleeve (2) by means of the double pin (5) (for gearbox with creeper gears) on the drive gear (3) (Fig. 5b).

**Note: Groove A in the sleeve (2) must be directed towards the differential ring gear (4) (Fig. 5).**

24. Check that the spring (1) is in place in the power take-off clutch and that the locating pins (2) are fitted (Fig. 6).

25. Check that the control finger «D» is in the forward direction (for gearbox with creeper gears) (Fig. 7).

26. Coat the mating face on the axle housing with Loctite 510 or an equivalent sealing compound.

27. Screw the two guide studs «G» on the housing (Fig. 6).

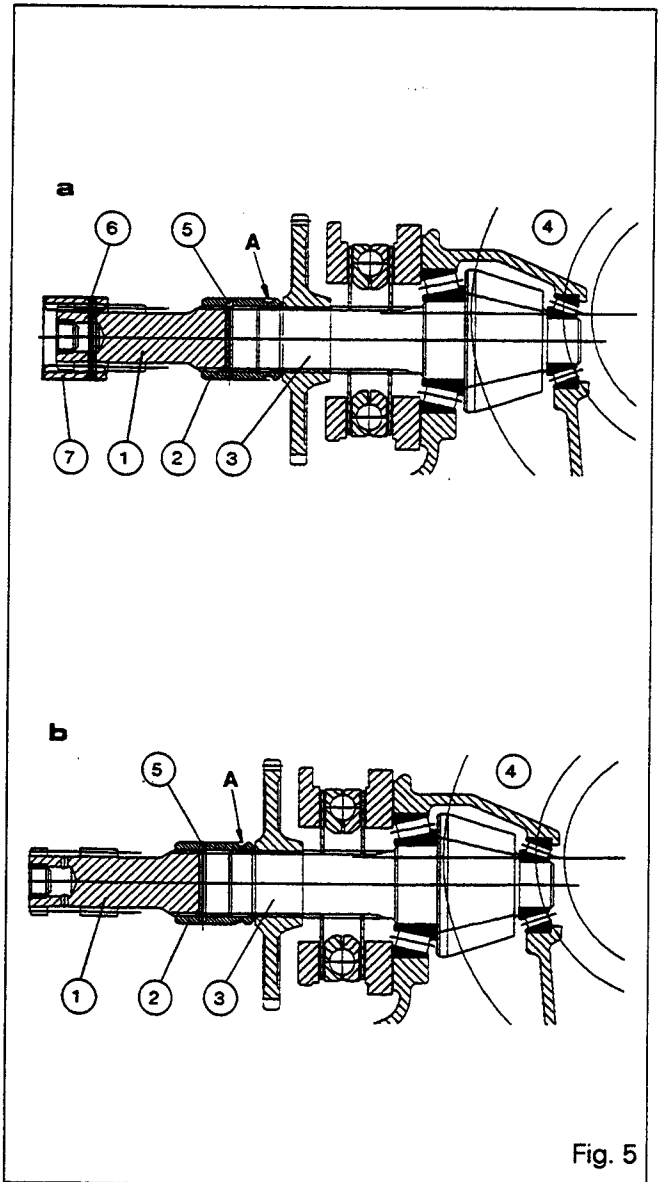

Fig. 5

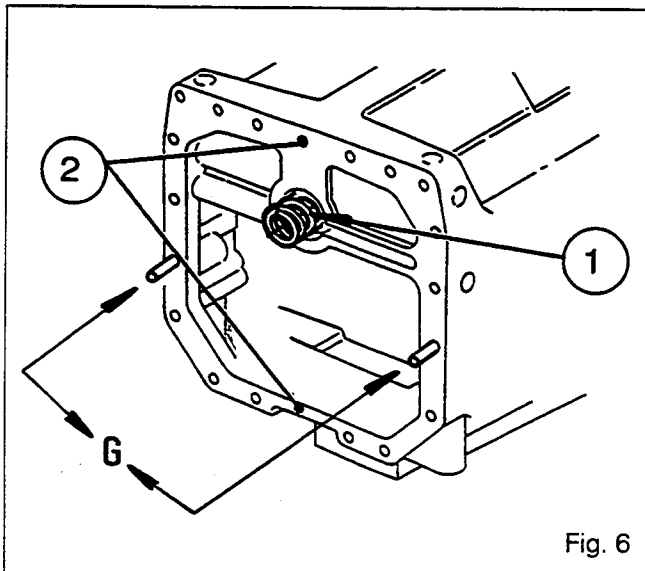

Fig. 6

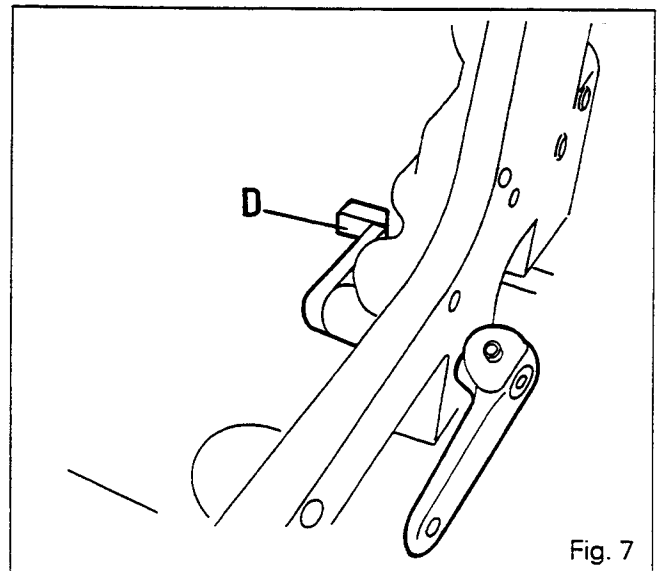

Fig. 7

### VISIBLE-RESULTS



## Splitting the tractor - Gearbox / rear axle

2B01.5

### On the gearbox

28. Replace the O-rings **(1)** on the Hare/Tortoise lines (Fig. 8).
29. Check that the PTO shaft is installed (see section 7E01). Recouple the tractor between the gearbox and the rear axle. Tighten the bolts to a torque of 155 to 195 Nm.
30. Lower the cab, fit the bolts on the shock absorbers **(1)** (Fig. 3) and tighten them to a torque of 200 to 270 Nm.
31. Remove the stand.
32. Turn and push the rod **(2)** in order to engage the finger in the fork. Tighten the bolt **(1)** after coating it with Loctite 241 (Fig. 2).
33. Check that the rod operates correctly. Reconnect and adjust the creeper gear control cable (see Section 5H01).
34. Reconnect the controls, harnesses, hoses, tubes and flexible couplings.
35. Top up the centre housing with oil.
36. Fit the 4WD drive shaft and the guard.
37. Reconnect the front differential lock control hoses (4WD).
38. Reconnect the batteries.
39. Reset the reverse shuttle electrohydraulic control system (if fitted). (See Section 5C02).
40. Bleed the clutch (see Section 4B01) or the control valve (Section 4A01), (according to version).
41. Check the hydraulic unions for leaks and the correct operation of the electric circuits.
42. Reinstall the protective guard, the sheet metal panels and the exhaust pipe.
43. Remove the wedges between the frame and the front axle. Release the handbrake.
44. Carry out road test on the controls for:
  - clutch,
  - electrohydraulically controlled reverse shuttle (if fitted),
  - creeper gears (if fitted).
45. Check for leaks on the mating face between the gearbox and the rear axle.

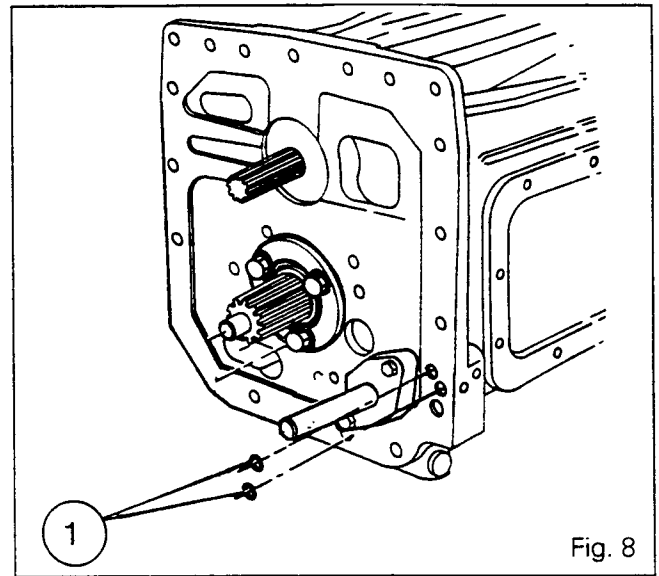
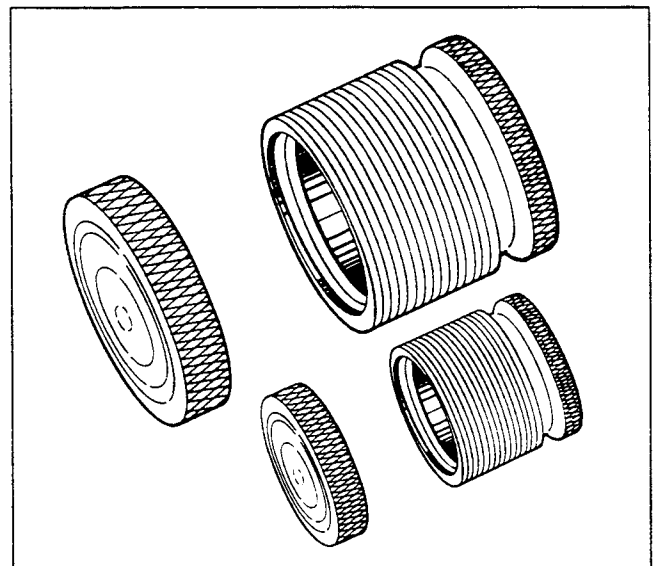

Fig. 8

### C. Service tool

**3376935M91 - Set of plugs for air conditioning couplings**





**VISIBLE-RESULTS**



***Splitting the tractor - Front frame / engine***

2C01.1

*2 C01 Splitting the tractor between the front frame  
and the engine*

CONTENTS

A.	Uncoupling _____	2
B.	Recoupling _____	3
C.	Service tool _____	3



## Splitting the tractor - Front frame / engine

### A. Uncoupling

1. Disconnect the two 4WD front axle control hoses.
2. Remove the guard and the 4WD drive shaft.
3. Remove the sheet metal panels and the exhaust pipe.
4. Disconnect the earth cables only from the batteries.
5. Disconnect and mark the positions of hoses and flexible connections, as follows:
  - the two Orbitrol steering hoses,
  - the hose from the cooler on the 17-bar valve,
  - the harness for the flowmeter and its three hoses located to the left of the fuel filter,
  - the connectors for the main harness above the engine,
  - the positive cable on the starter,
  - the inlet sleeve between the turbocharger (if fitted) and the air filter,
  - the suction pipe between the air filter and the exhaust pipe (6180 and 6190).
6. Drain the cooling system. Disconnect the lower and upper hoses from the radiator.
7. Remove the upper attachment on the radiator.
8. Remove the air conditioning compressor and bracket assembly and tilt it forwards with its two hoses (according to option fitted).

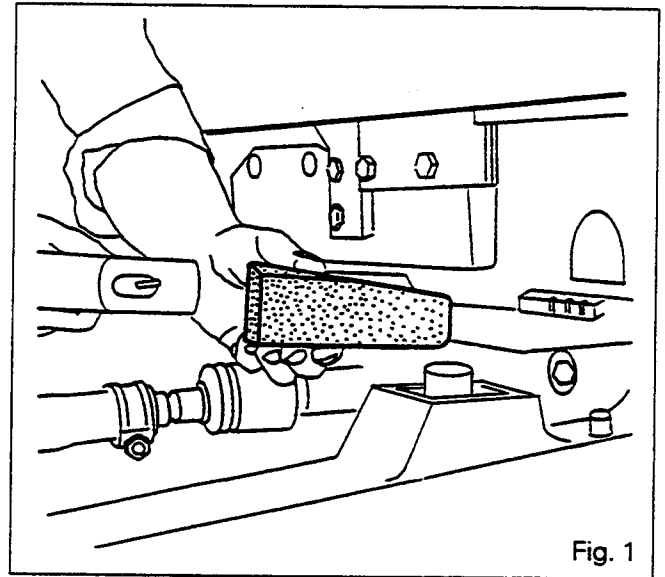

Fig. 1

9. Remove the front weights.
10. Immobilise the tractor. Apply the handbrake. Position wedges between the frame and the front axle (Fig. 1).
11. Loosen the bolts attaching the engine to the front frame.
12. Support the tractor under the frame using a trolley jack and separate the engine from the frame (Fig. 2).

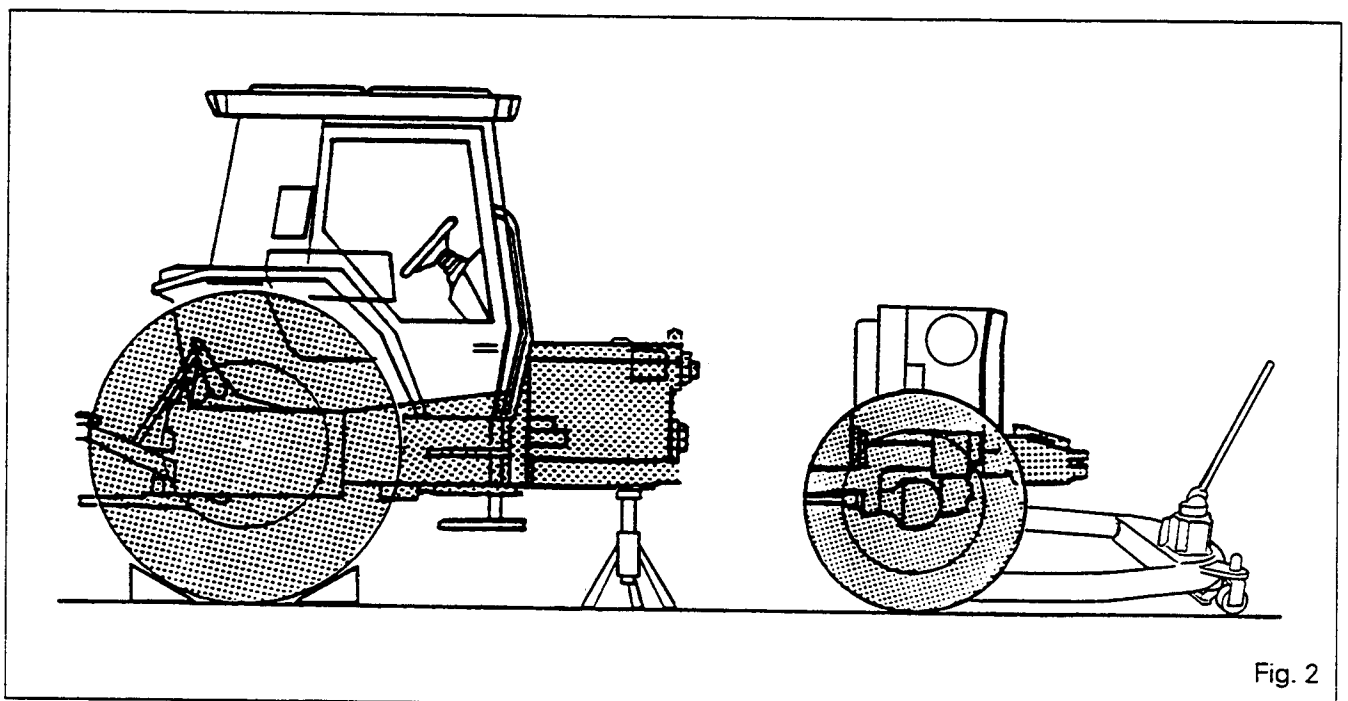

Fig. 2



## B. Recoupling

13. Screw two guide stud (locally manufactured) into diametrically opposite positions on the front frame.
14. Fit the frame to the engine.
15. Install the bolts and tighten to the specified torques:
  - 4-cylinder engines: see Fig. 3,
  - 6-cylinder engines: see Fig. 4.
16. Refit the air conditioning compressor and bracket assembly and the upper attachment on the radiator.
17. Reconnect the inlet sleeve, suction pipe, harnesses, hoses, flexible connections, and pipes.
18. Reinstall the front weights.
19. Top up the cooling system.
20. Reconnect the batteries.
21. If the tractor is equipped with a flowmeter, purge the injection pump supply system (4-cylinder engines).
22. Start the engine and check:
  - the hydraulic systems for any leaks,
  - the correct operation of the electrical systems.
23. Refit the sheet metal panels, the exhaust pipe, the drive shaft and the 4WD guard.
24. Reconnect the front axle control hoses.
25. Carry out road test

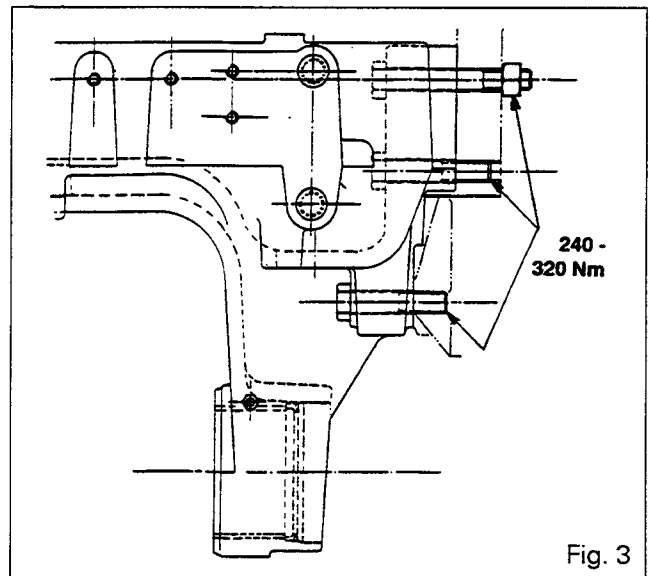

Fig. 3

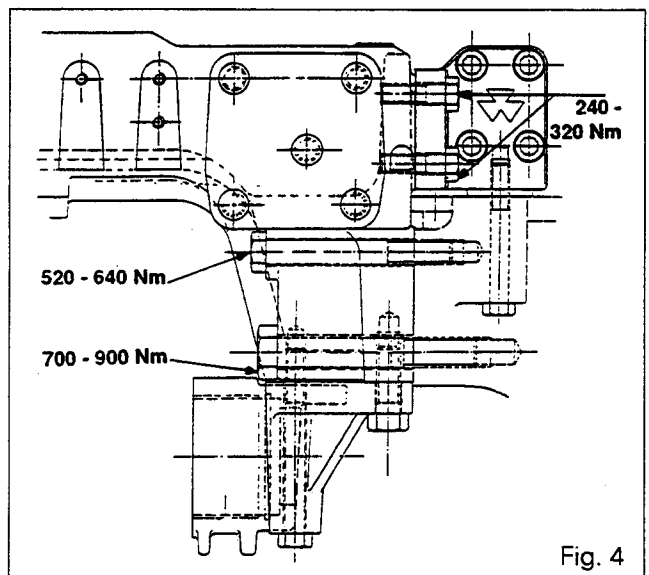
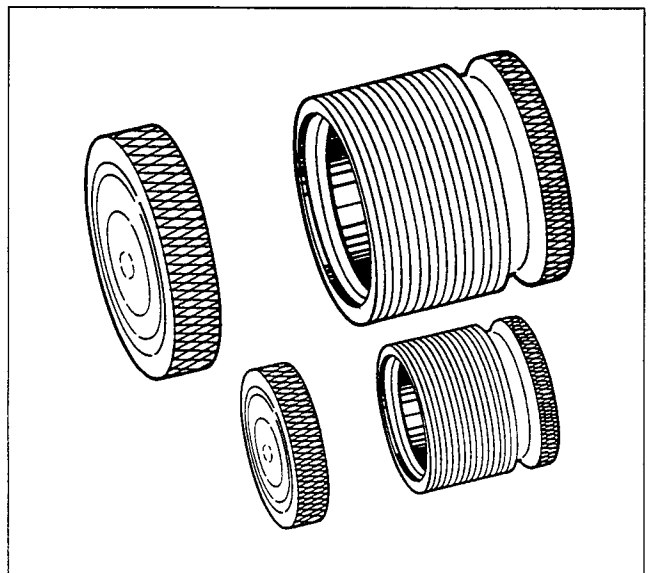

Fig. 4

## C. Service tool

**3376935M91 - Set of plugs for air conditioning couplings**







## **3 . ENGINE**

### **Contents**

- 3 A01 GENERAL**
- 3 B01 ENGINE FLYWHEEL**
- 3 C01 SPACER - SPRING LOADED CLUTCH**
- 3 C02 SPACER - PRESSURE LOADED CLUTCH**

**VISIBLE-RESULTS**



**Engine - General**

*3 A01 General*

CONTENTS

<b>A. Introduction</b> _____	<b>2</b>
<b>B. Main specifications</b> _____	<b>3</b>
<b>C. Viscostatic fan</b> _____	<b>6</b>





3A01.2

---

## 6100 SERIES TRACTORS

---

### **Engine - General**



---

#### **A. Introduction**

---

The purpose of this section is to provide general information about the engines used for the 6100 range.

For all information on: technical data, adjustments and removal and fitting procedures, refer to one or other of the publication listed opposite :

1. Workshop manual for all types of Perkins engines manufactured for MF tractors, published by Massey Ferguson under reference 1856562 M1.
2. Workshop manual specifically for the 1000 series engines published by Massey Ferguson under the reference 1646906 M1.



## Engine - General

### B. Main specifications

	MF 6110	MF 6120	MF 6130
Engine type	4.41	4.41	1004-4TLR
Perkins list n°	LM 31282	LM 31283	AH 31279
No of cylinders	4	4	4
Bore (mm)	101	101	100
Stroke (mm)	127	127	127
Capacity (liter)	4,06	4,06	4
Compression ratio	16:1	16:1	16:1
Power at 2200 rpm (kW) (DIN 70020)	52	58,9	62,6
Max. torque (Nm)	269	286	325
at engine speed of (rpm)	1400	1400	1400
Idling speed (rpm)	750	750	750
Nominal speed (rpm)	2200	2200	2200
Max. speed no load (rpm)	2350	2350	2310
Fuel injection pump :			
Make and type	CAV DPA	CAV DPA	LUCAS DP200
Boost control	No	No	No
F.I.P.	3340 F 090 T	3340 F 080 T	8920 A 030 T
Perkins code	2643 C 307	2643 C 308	2644 C 104
Fuel pump code letters	AD	BD	DC
Governor spring position code	3	3	2
Rotation	Clockwise	Clockwise	Clockwise
No 1 cylinder output	W	W	W
Static timing angle (degrees)	-	-	13
Engine position	TDC	TDC	100° before No 1 TDC
Engine check angle (degrees)	280,5	280,5	No check angle
Pump check angle (degrees)	292	293	336,5
Static timing piston position (mm)	Not applicable	N/A	N/A
Injectors :			
Make	Lucas	Lucas	Lucas
Code	HL	HU	JK
Holder	2645 A 302	2645 A 302	2645 A 302
Nozzle	2645 K 602	2645 A 604	2645 A 613
Set and reset pressure (atmospheres)	230	220	220
Aspiration system	Naturally aspirated	Naturally aspirated	Turbo Garret
Mini boost pressure at 2200 rpm			
full load (mm Hg)	-	-	558
(Kpa)	-	-	-
(PSI)	-	-	-
Valve spring	Single	Single	Double
Valve inserts (In / Ex)	Exh	Exh	Yes / Yes
Valve angle (degrees - In / Ex)	45 / 45	45 / 45	30 / 45
Valve adjustment (mm - In / Ex)	0,20 / 0,45 <sup>+0.05</sup> hot or cold	0,20 / 0,45 <sup>+0.05</sup> hot or cold	0,20 / 0,45
Engine oil cooler	No	No	Yes
No of thermostats	1	1	1
Opening temperature	82° C	82° C	82°CC
Fan	-	-	Standard
Piston cooling jets	No	No	Yes
Oil filters	1	1	1
Fuel filters	1	1	1



## 6100 SERIES TRACTORS

3A01.4

### Engine - General

	MF 6140	MF 6150	MF 6160
Engine type	1104-4T2	1004-4THR2	1006-6HR4
Perkins list No	AH 31278	AH 31277	YA 31251
No of cylinders	4	4	6
Bore (mm)	100	100	100
Stroke (mm)	127	127	127
Capacity (liter)	4	4	6
Compression ratio	16:1	16:1	16.5:1
Power at 2200 rpm (kW) (DIN 70020)	66,2	69,9	73,5
Max. torque (Nm)	359	386	403
at engine speed of (rpm)	1400	1200	1200
Idling speed (rpm)	850	850	850
Nominal speed (rpm)	2200	2200	2200
Max. speed no load (rpm)	2310	2310	2310
Fuel injection pump :			
Make and type	Lucas DP200	Lucas DP200	CAV DPA
Boost control	Yes	Yes	No
F.I.P.	8920 A 022 T	8920 A 002 T	3369 F 170 T
Perkins code	2644 C 102	2644 C 101	2643 D 629 / LK
Fuel pump code letters	CC	BC	LK
Governor spring position code	1	2	5
Rotation	Clockwise	Clockwise	Clockwise
No 1 cylinder output	W	W	Y
Static timing angle (degrees)	13	-	22
Engine position	100° before No 1 TDC	100° before No 1 TDC	TDC
Engine check angle (degrees)	No checking angle	No checking angle	326,5
Pump check angle (degrees)	338,5 Locking angle	336,5 Locking angle	337,5
Static timing piston position (mm)	Not applicable	Not applicable	5,92
Injectors			
Make	Lucas	Lucas	CAV
Code	NR	JY	JU
Holder	2645 L 303	2645 A 302	LRB 67014
Nozzle	2645 L 614	2645 A 621	JB 6801 106
Set and reset pressure (atmosphere)	230	250	220
Aspiration system	Turbo Garret	Turbo Wastegate	Naturally aspirated
Mini boost pressure at 2200 rpm			
full loac (mm Hg)	914	813	-
(Kpa)	21.86	108.34	-
(PSI)	17.67	15.72	-
Valve spring	Double	Double	Single
Valve inserts (In / Ex)	Yes / Yes	Yes / Yes	No
Valve angle (degrees - In / Ex)	30 / 45	30 / 45	45 / 45
Valve adjustment (mm - In / Ex)	0,20 / 0,45	0,20 / 0,45	0,20 / 0,45
Engine oil cooler	Yes	Yes	No
No of thermostats	1	1	2
Opening temperature	82° C	82° C	82° C
Fan	Standard	Viscostatic	Viscostatic
Piston cooling jets	Yes	Yes	No
Oil filters	1	1	1
Fuel filters	1	1	2

VISIBLE-RESULTS

**Engine - General**

	MF 6170	MF 6180	MF 6190
Engine type	1006-6HR3	1006-6TLR2	1006-6T7
Perkins list No	YA 31250	YB 31265	YB 31245
No of cylinders	6	6	6
Bore (mm)	100	100	100
Stroke (mm)	127	127	127
Capacity (liter)	6	6	6
Compression ratio	16.5/1	16.0/1	16.0/1
Power at 2200 rpm (kW) (DIN 70020)	78,5	88,3	95,7
Max. torque (Nm)	440	490	474
at engine speed of (rpm)	1200	1400	1200
Idling speed (rpm)	850	850	850
Nominal speed (rpm)	2200	2200	2200
Max. speed no load (rpm)	2310	2310	2350
Fuel injection pump :			
Make and type	CAV DPA	Stanadyne	CAV DPA
Boost control	No	No	No
F.I.P.	3369 F 100	DB 2635 5110	3363 F 850
Perkins code	2643 D 804	2643 U 608	2643 D 615 / KK
Fuel pump code letters	UK	DL	KK
Governor spring position code	2	-	7
Rotation	Clockwise	Clockwise	Clockwise
No 1 cylinder output	Y	-	Y
Static timing angle (degrees)	17	12	18
Engine position	TDC	TDC	TDC
Engine check angle (degrees)	325,5	332	325
Pump check angle (degrees)	334	338	334
Static timing piston position (mm)	3,56	Not applicable	3,99
Injectors			
Make	CAV	Stanadyne	CAV
Code	JU	NV	JT
Holder	LRB 67014	2645 L 307	LRB 67032
Nozzle	JB 6801 106	2645 L 616	JB 6801 104
Set and reset pressure (atmosphere)	220	230	250
Aspiration system	Naturally aspirated	Turbo Garret	Turbo Schwitzer S 2B
Mini boost pressure at 2200 rpm			
full load (mm Hg)	-	508	450,04
(Kpa)	-	67,7	60
(PSI)	-	9,8	8,7
Valve spring	Single	Single	Single
Valve inserts (In / Ex)	No	Yes / Yes	No
Valve angle (degrees - In / Ex)	45 / 45	30 / 45	30 / 45
Valve adjustment (mm - In / Ex)	0,20 / 0,45	0,20 / 0,45	0,20 / 0,45
Engine oil cooler	No	Yes	Yes
No of thermostats	2	2	2
Opening temperature	82° C	82° C	82° C
Fan	Viscostatic	Viscostatic	Viscostatic
Piston cooling jets	No	Yes	Yes
Oil filters	1	1	1
Fuel filters	2	2	2



## Engine - General

### C. Viscostatic fan

#### Description

The 1000 series engines can be fitted with a cooling fan with an Eaton viscous coupling. This device increases power by 2 to 3hp.

The viscous coupling is made up of three main parts:

- The driving part powered by the engine and composed of shaft (1) integral with plate (2) with annular grooves.
- The driven part composed of hub (6) on which are mounted the fan and body (7) also with annular grooves.
- The regulating part composed of thermostatic spring (3) controlling valve (4).

The centre of the device has a reservoir (5) filled with a viscous silicone fluid.

#### Method of operation

When the temperature of the air going through the radiator reaches a predetermined value, thermostatic spring (3) acts on valve (4) which opens orifice a. The liquid is driven towards the annular grooves on hub (2) and body (7) by centrifugal force. The torque is transmitted by the internal friction of the very viscous fluid and its adhesion to the walls. The fan is thus driven, thereby increasing airflow and overall cooling efficiency.

The speed of the fan varies continually over the whole regulatory range depending on the temperature.

When the temperature of the air going through the radiator decreases, the spring closes the valve and stops the liquid from coming into contact with the friction area. The fluid gradually returns to reservoir (5) via pipe b, the fan is disengaged, leaving only a slight residual torque.

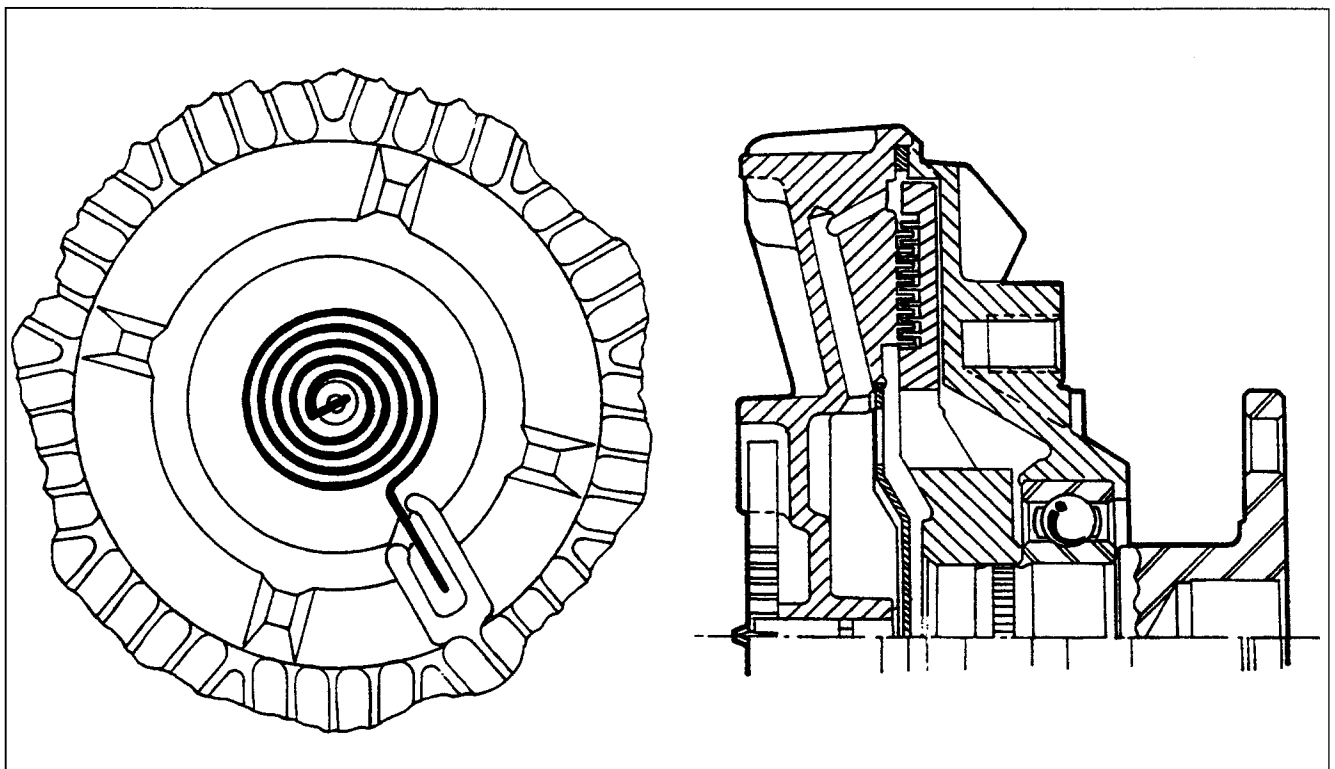
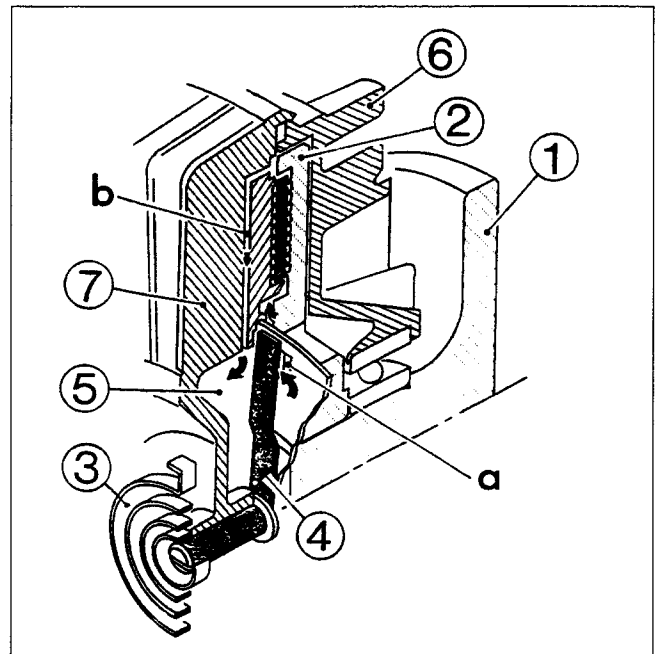

VISIBLE-RESULTS



**Engine - Engine flywheel**

*3 B01 Engine flywheel*

CONTENTS

-	<b>General</b> _____	<b>2</b>
A.	<b>Removing and refitting the shock absorber</b> _____	<b>6</b>
B.	<b>Removing and refitting the engine flywheel</b> _____	<b>7</b>
C.	<b>Replacing the flywheel ring gear</b> _____	<b>7</b>
D.	<b>Service tool</b> _____	<b>7</b>



3B01.2

---

## 6100 SERIES TRACTORS

---



### **Engine - Engine flywheel**

---

#### **General (Figures 1 and 2)**

---

The shock absorber **(6)**, mounted on the engine flywheel and splined onto the input shaft, provides a smooth link between the engine and the clutch. This system is fitted on Dynashift and Speedshift type tractors with 4 and 6 cylinder engines.

To increase the reliability of the shock absorber (with spring-loaded clutch), its axial travel is limited by a spacer **(3)** that is fitted in the engine flywheel **(1)** and a bush **(9)**.

On tractors of types 6170 to 6180 from serial number F058049 and 6190 tractors (with pressure-loaded clutch) are equipped with a shock absorber **(6)** that is different from the one equipped with a spring-loaded clutch.

This shock absorber **(11)** is fitted in the crankshaft and supports the input shaft.

#### **Special points (Fig. 1)**

- Force-fitting of the washer **(10)** in the spacer **(3)**.
- When recoupling the tractor between the engine and the gearbox, check that the bush **(9)** is in place.
- **4-cyl. installation:** Long spacer **(3)** - Short bush **(9)**.
- **6-cyl. installation (6160 tractors):** Short spacer **(3)** - Long bush **(9)**.



**Engine - Engine flywheel**

3B01.3

**Spring-loaded clutch**

**4-cylinder engine (6150)**

**6-cylinder engine (6160)**

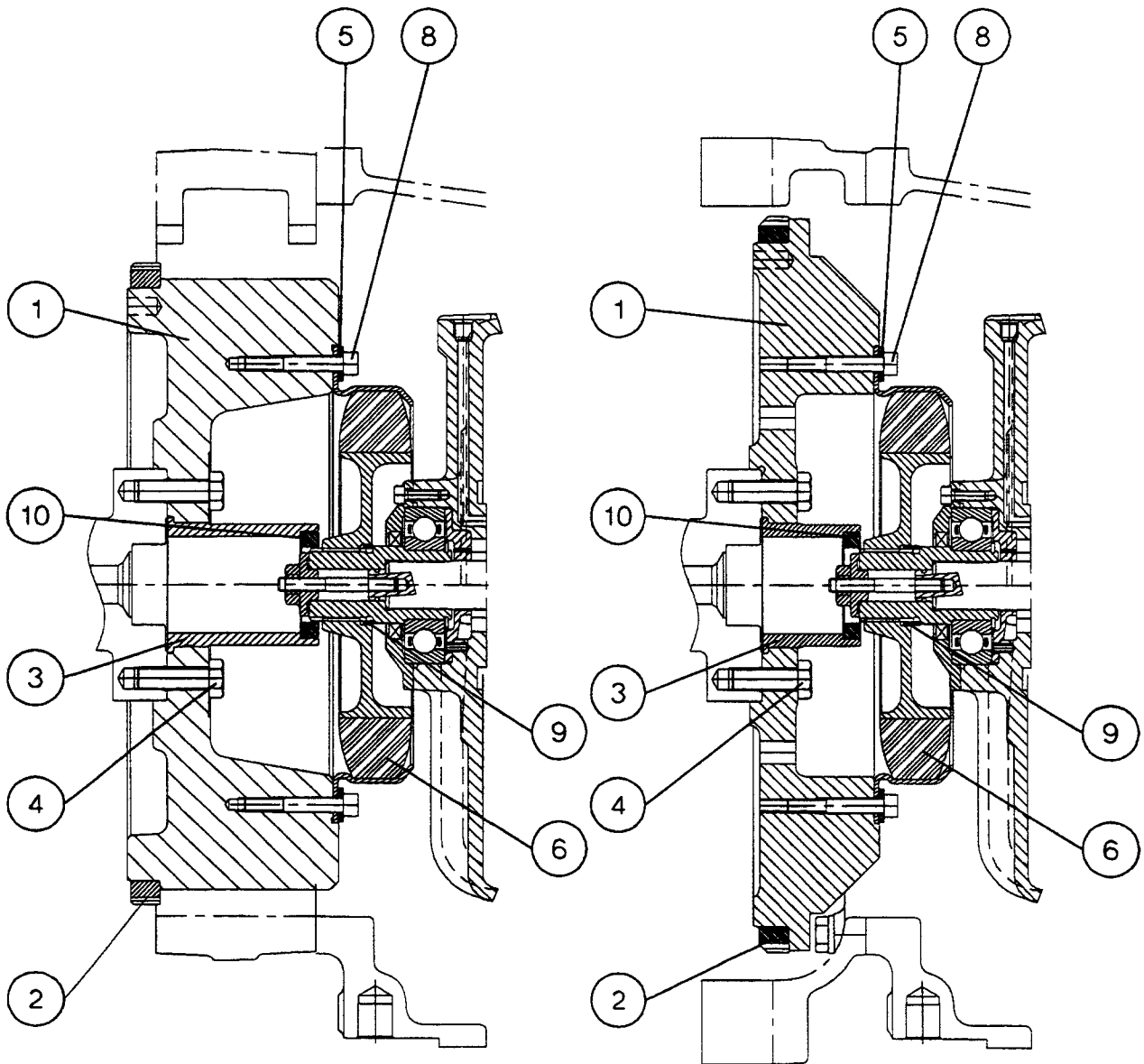

**List of parts**

- (1) Engine flywheel
- (2) Flywheel ring gear
- (3) Spacer
- (4) Bolt
- (5) Washer

- (6) Shock absorber
- (8) Bolt
- (9) Bush
- (10) Washer

Fig. 1





3B01.4

6100 SERIES TRACTORS



# Engine - Engine flywheel

**4-cylinder engine (6110 to 6140)  
Spring-loaded clutch**

**6-cylinder engine (6170 to 6180)  
Pressure-loaded clutch**

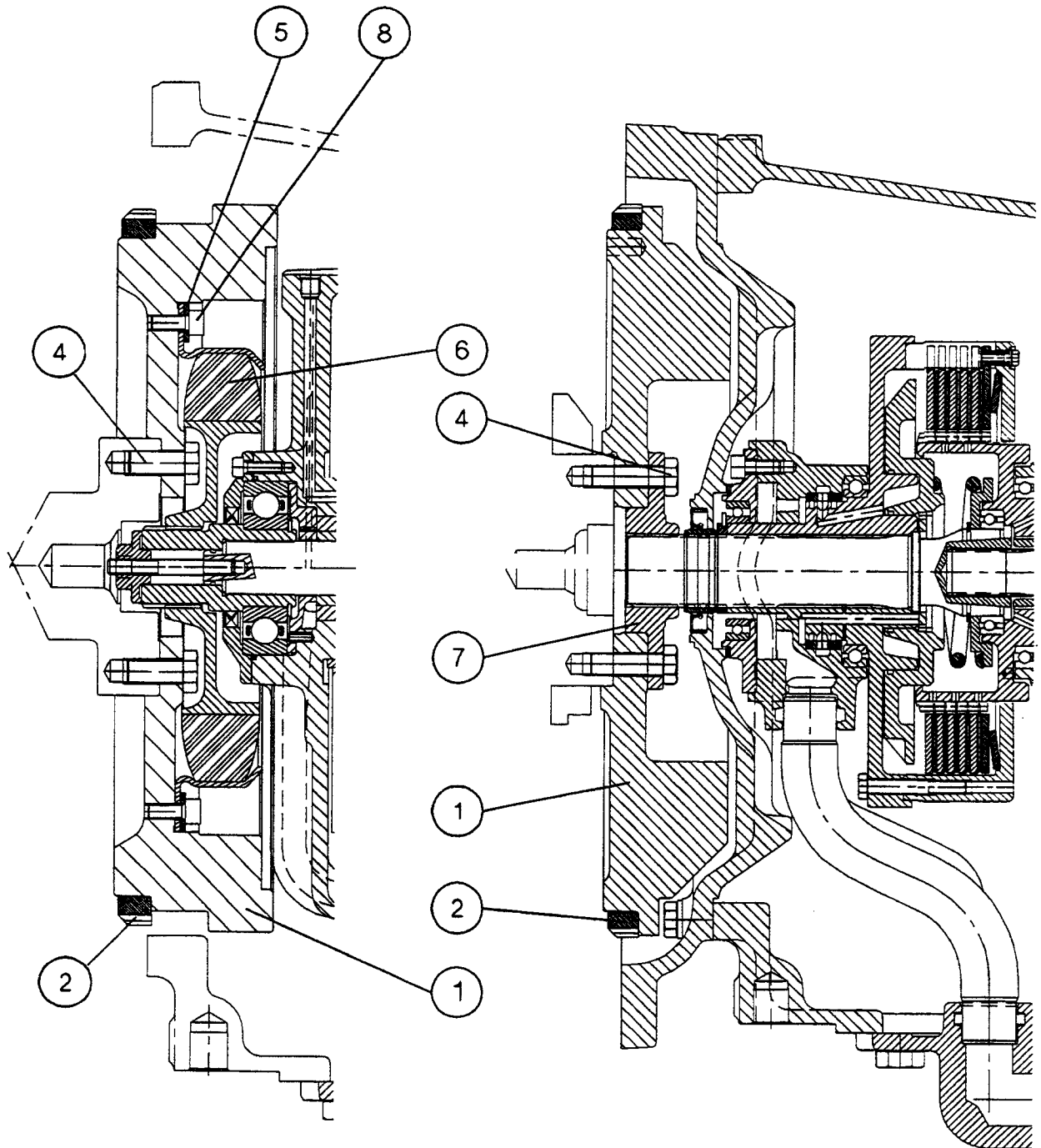

### List of parts

- (1) Engine flywheel
- (2) Flywheel ring gear
- (4) Bolt
- (5) Washer

- (6) Shock absorber
- (7) Hub
- (8) Bolt

Fig. 2

**VISIBLE-RESULTS**



**Engine - Engine flywheel**

**6-cylinder engine  
Pressure-loaded clutch  
6170 to 6180, from serial number F058049, and 6190**

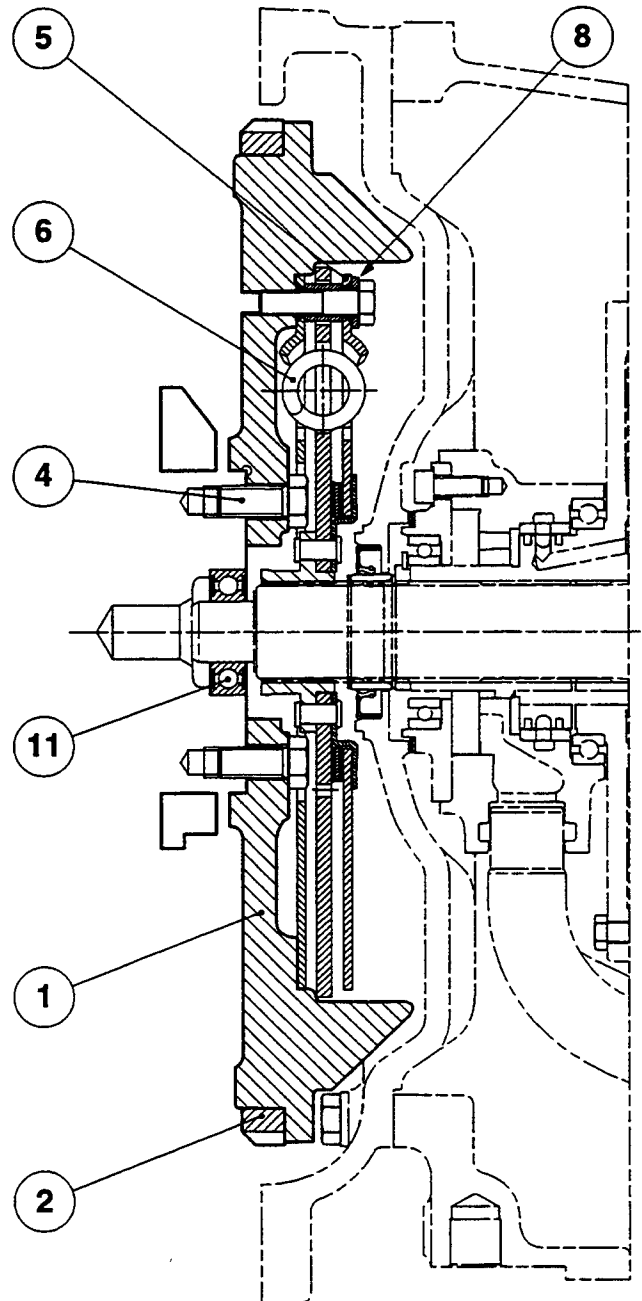

**List of parts**

- (1) Engine flywheel
- (2) Flywheel ring gear
- (4) Bolt
- (5) Washer

- (6) Shock absorber
- (8) Bolt
- (11) Ball bearing

Fig. 3



3B01.6

## 6100 SERIES TRACTORS



# Engine - Engine flywheel

### A . Removing and refitting the shock absorber (Fig. 3)

**Note:** Tractors of types 6170 to 6180 from serial number F058049 onwards and 6190 tractors (with pressure-loaded clutch) are fitted with an LUK shock absorber (see description headed "General").

#### Removal

1. Uncouple the tractor between the engine and the gearbox (see Section 2A01).
2. Remove the bolts (8) and washers (5).
3. Remove the shock absorber. If necessary, use a suitable tool to extract the bearing (11) (Fig. 4).

#### Refitting

4. Lightly coat the splines on the shock absorber (6) with grease of type GN + Molykote and refit it. Coat the washers and bolts with Loctite 270 and, then, fit them and tighten them to a torque of between 29 and 37 Nm.

**Note:** On tractors of types 6170 to 6180, according to the serial number, and 6190 tractors:  
If the bearing (11) (Fig. 4) is removed, it must be fitted using a suitable fixture pressing on the bearing's outer housing.

Centre the shock absorber (6) on the flywheel using service tool 3378112M1 (Fig. 5), with the longer section of the shock absorber facing the flywheel (see Fig. 3). Fit the washers (5) and bolts (8) after coating them with Loctite 270, and tighten them to a torque of between 40 and 56 Nm.

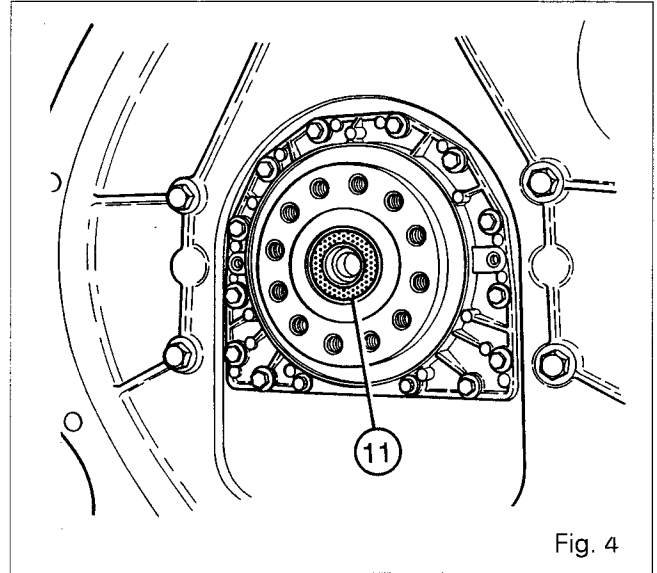

Fig. 4

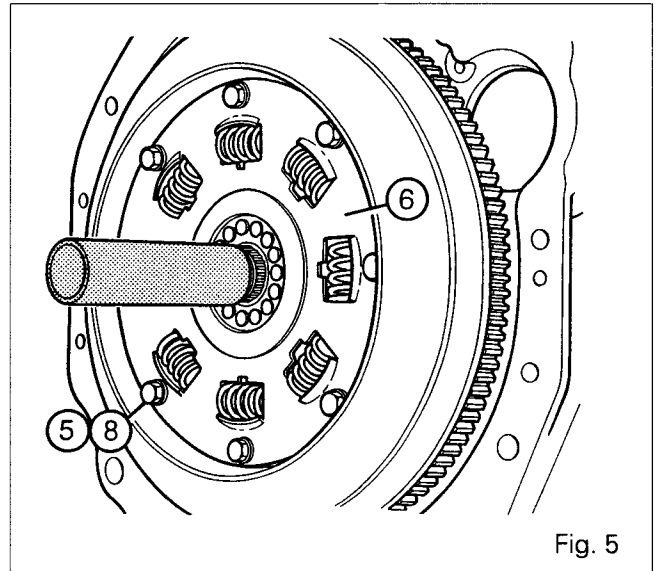

Fig. 5



## Engine - Engine flywheel

### B . Removing and refitting the engine flywheel (Figures 1 to 3)

#### Removal

1. Split the tractor between the engine and the gearbox (see Section 2A01).
2. Immobilise the engine flywheel.
3. Remove bolts (8) and washers (5). Remove the shock absorber (6). Remove bolts (4). Remove the engine flywheel with the bush (3) (if fitted).

#### Refitting

4. Screw the two guide studs into the flywheel attachment holes on the crankshaft.
5. Refit the engine flywheel with the bush (3) (according to the type). Take out the guide studs. Lightly coat the bolts with Loctite 270 and tighten them a torque of between 110 and 140 Nm.
6. Refit and centre the shock absorber (6). Fit the washers (5). Lightly coat the bolts (8) with Lotite 270 and tighten them a torque of between 29 and 37 Nm. On tractors 6170 to 6190, see Part A, operation 4.

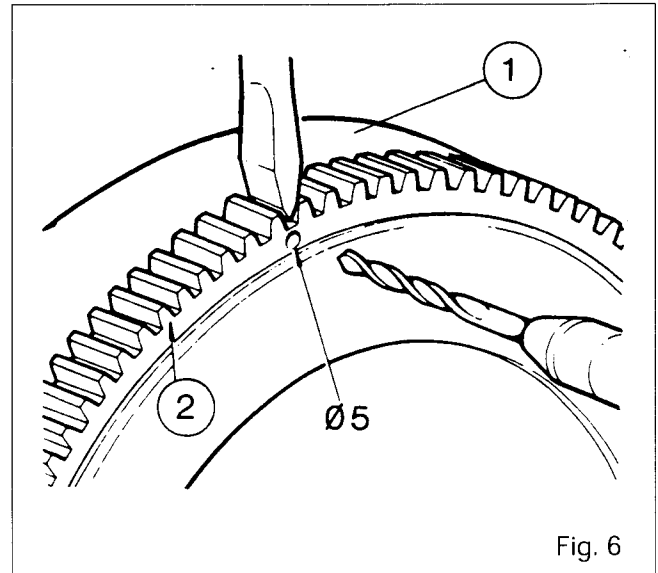

Fig. 6

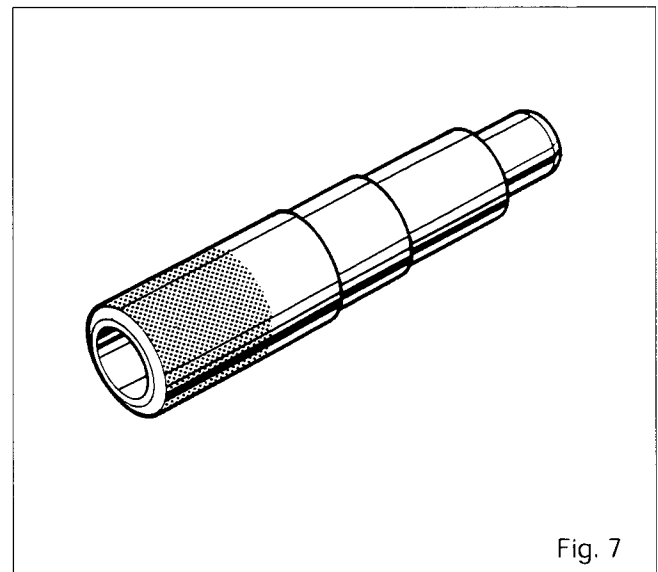

Fig. 7

### C . Replacing the flywheel ring gear

#### Disassembly

1. Remove the engine flywheel (see Part B).
2. Drill a hole (5 mm dia., 16 mm deep). Split the ring gear with a chisel, as shown in Fig. 6.  
**Note: Provide for protection against chips of metal when breaking the ring gear.**

#### Reassembly

3. Heat a new ring gear to 245°C, in a furnace only.
4. Fit the ring gear (2) on the engine flywheel (1) (with the tooth chamfer side facing the engine) and quickly push the ring gear fully home. Allow to cool slowly.

### D . Service tool

Tool available through MF network

3378112M1 - Shock absorber centring tool (Fig. 7)

**VISIBLE-RESULTS**



**Motor - Spacers**

*3 C01 Spacers - Spring-loaded clutch*

CONTENTS

A.	Spacer (4 cyl. engine) _____	2
B.	Spacer (6 cyl. engine) _____	3



3C01.2

## 6100 SERIES TRACTORS



### Motor - Spacers

#### A. Spacer (4 cyl. engine)

Tractors fitted with the 1004 engine and spring-loaded clutch are equipped with a spacer, 89 mm thick, mounted between the engine and the gearbox. The lower attachment is provided by studs of various lengths screwed onto the gearbox casing (Fig. 1).

#### Disassembly

1. Split the tractor between the engine and the gearbox (Section 2 A01)
2. Remove the spacer.
3. If necessary, extract the studs from the gearbox.

#### Refitting

4. Clean the mating faces on the spacer and the gearbox.
5. If the studs were removed, coat them with Loctite 270. Screw them in place and lock them, according to their lengths, in their positions as shown in Fig. 1.
6. Recouple the tractor between the engine and the gearbox (Section 2 A01).

#### Tightening torque

(1) to (15) = 100 to 130 Nm

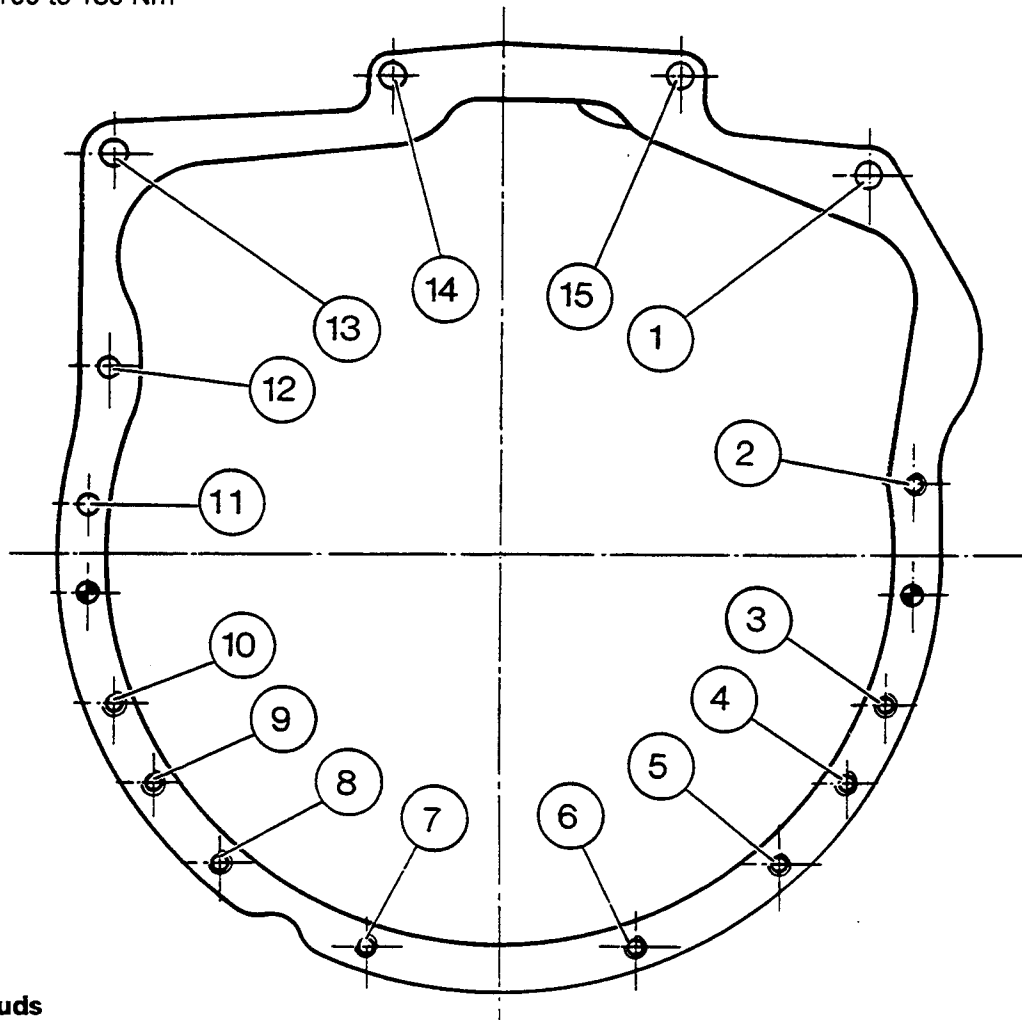

#### Length of studs

(3) = 145

(5) (8) = 155

(6) (7) = 130

Fig. 1

VISIBLE-RESULTS



## Motor - Spacers

### B. Spacer (6 cyl. engine)

This spacer is fitted on tractors with the spring loaded clutch.

#### Disassembly

1. Remove the tool box.
2. Split the tractor between the engine and the gearbox (Section 2 A01).
3. Remove two spacer attaching bolts from the gearbox.
4. Screw two locally manufactured guide studs in their place.
5. Remove the 13 bolts and the spacer.
6. Remove the locating pins.

#### Refitting

7. Clean the mating faces on the spacer and gearbox.
8. Reinstall the locating pins.
9. Repeat operation 4 and carry out operation 5 in the reverse order.
10. Remove the guide studs. Fit and tighten the 15 bolts to a torque of 100 to 130 Nm.  
**Note: The countersunk head bolt /13\ must be correctly positioned (Fig. 2).**
11. Carry out operations 1 and 2 in the reverse order.

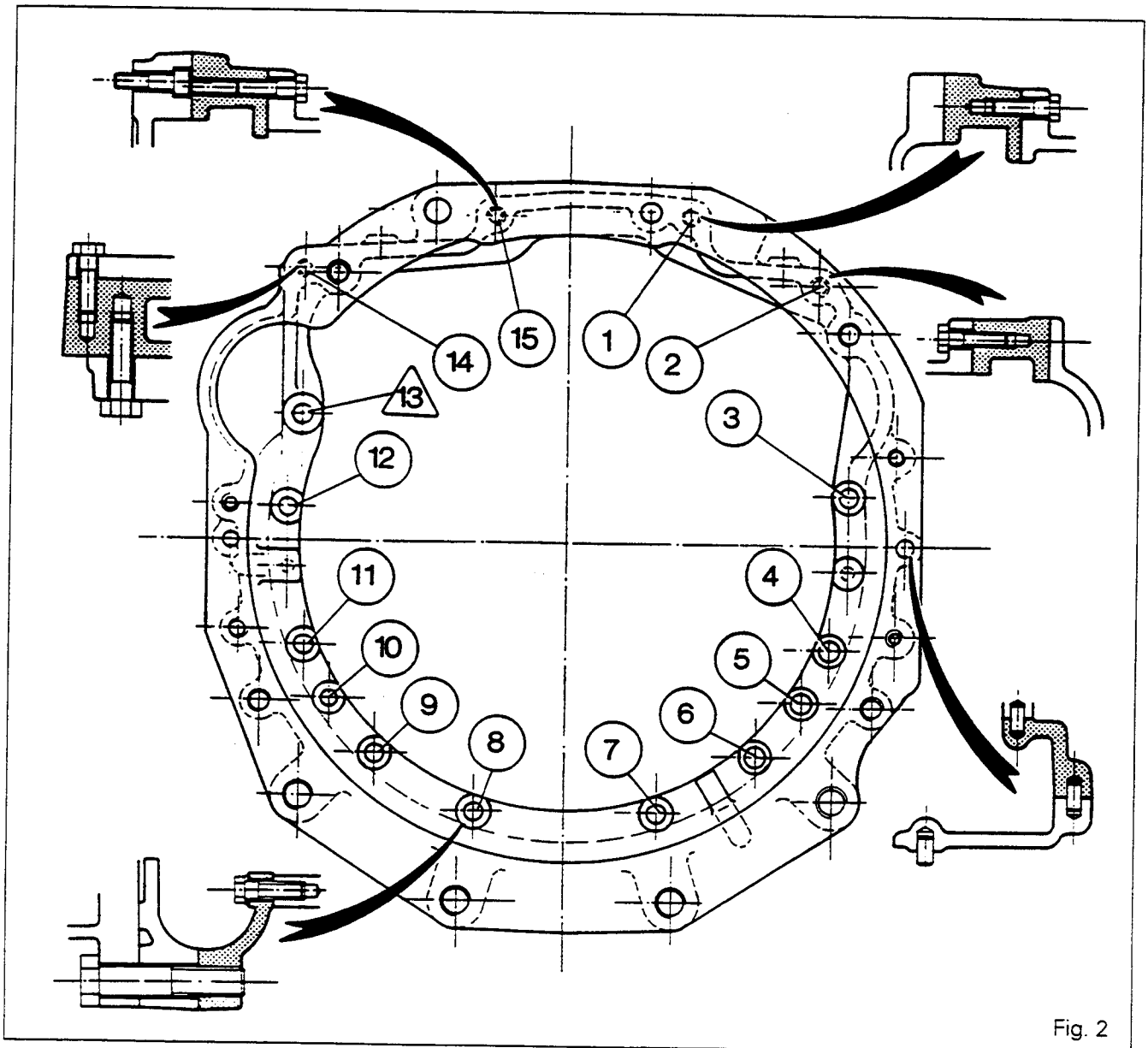

Fig. 2



**VISIBLE-RESULTS**



**Engine - Spacer**

*3 C02 Spacer - Pressure-loaded clutch*

CONTENTS

-	<b>General</b> _____	2
A.	<b>Removing and refitting the spacer</b> _____	2
B.	<b>Removing and refitting the seal</b> _____	2
C.	<b>Service tool</b> _____	3

**Engine - Spacer****General**

6100 series tractors fitted with the pressure-loaded clutch are equipped with a spacer (16) mounted between the engine and the gearbox.

This spacer acts as a partition between the engine flywheel and the wet clutch. Tight sealing is provided by a lip seal.

The contact face of the spacer against the gearbox is coated with Loctite 510.

**Note: On 6170 - 6180 series tractors as from serial number F058049 and on 6190 series tractors: fitting of an input shaft (7) (Fig. 2) centred in the crankshaft.**

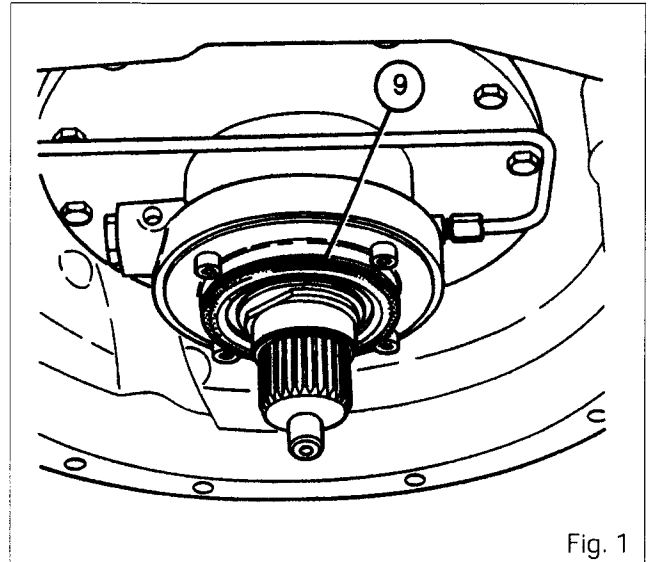

Fig. 1

**A. Removing and refitting the spacer**

**Note: When the spacer is replaced, it is necessary to repeat the shimming of the clutch assembly (Section 4 A01).**

**Disassembly**

1. Split the tractor between the engine and the gearbox (Section 2 A01).
2. Drain the oil from the gearbox.
3. Remove two attaching bolts from the spacer and screw two guide studs in their place, diametrically opposite on the gearbox.
4. Remove the remaining bolts. Place the protector 3378012M1 (C) on the input shaft. Detach and remove the spacer.

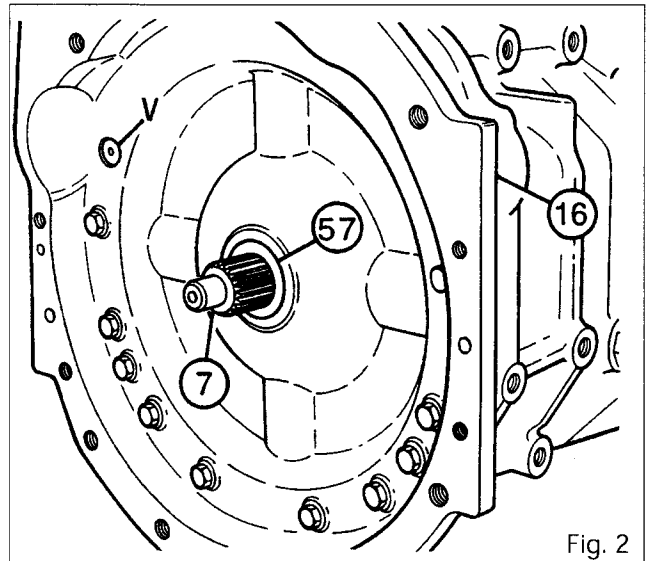

Fig. 2

**Reassembly**

5. Clean the mating faces on the spacer and gearbox.
6. Smear the mating face on the gearbox with Loctite 510 or equivalent.
7. Position the locating pins.
8. Screw two guide studs on the gearbox.
9. Position the protector on the input shaft.
10. Check that the shims (9) are installed (Fig. 1).
11. Reinstall the spacer. Remove the guide studs. Tighten the 15 bolts smeared with Loctite 270 to a torque of 100 to 130 Nm.
- Note: The countersunk head of bolt "V" must be correctly positioned (Fig. 2).**
12. Recouple the engine with the gearbox.

**B. Removing and refitting the seal (Fig. 2)****Removal**

13. Remove the spacer (see A).
14. Extract the seal (57).

**Refitting**

15. Clean the seating for the seal on the spacer.
16. Fit the seal with a press and a suitable fixture.
17. Fit the spacer (See A).



6100 SERIES TRACTORS



3C02.3

**Engine - Spacer**

**C . Service tool**

Tool supplied by the MF network  
3378012M1 - Oil seal protector

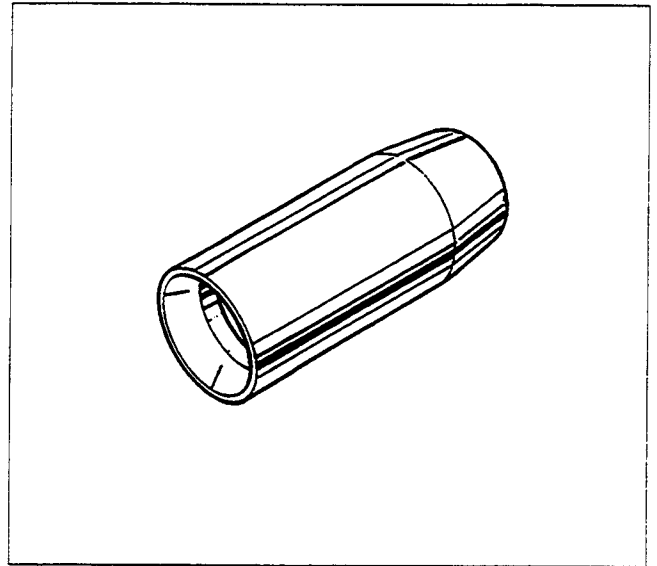

**VISIBLE-RESULTS**



## **4 . CLUTCH**

### **Contents**

**4 A01 PRESSURE LOADED CLUTCH**

**4 B01 SPRING LOADED CLUTCH**





4 A01 Pressure-loaded clutch

CONTENTS

-	General	2
A.	Removing and refitting the oil seal and the O-ring	4
B.	Removing, refitting and shimming the clutch	4
C.	Dismantling and reassembling the clutch	5
D.	Removing and refitting the control valve	7
E.	Bleeding the clutch control	8
F.	Adjusting the clutch pedal	8
G.	Service tools	9
H.	Speedshift version	10





4A01.2

## 6100 SERIES TRACTORS



# Clutch - Pressure-loaded

### General

#### Description

The new engine clutch system of the pressure-loaded type fitted on tractors in series 6170 to 6190 is of the oil bath multiple-disc type.

The system's construction and operating principle are identical to those of the system fitted on 8100 tractors.

The hydraulic clutch which transmits movement is similar to a PTO clutch but on a larger scale.

This clutch is controlled by a hydraulic valve fitted on the right-hand side of the gearbox which is, itself, operated by the clutch master cylinder.

To avoid problems with reliability, the oil used for this clutch must, imperatively, comply with standard MF M1143 or M1144.

Compared with the dry clutch, the wet clutch (oil bath) has the following advantages:

- enhanced reliability and longer service life,
- smaller load on pedal.

#### Construction

The wet clutch assembly is installed between the engine flywheel and the primary shaft of the Dynashift gearbox.

The input shaft (7) crosses through the spacer (16) which separates the engine flywheel from the transmission oil. The shaft (7) is constantly meshed with the fixed hub on the engine flywheel.

It rotates with the clutch housing (23) through splining. The clutch housing is equipped with friction plates (45) and the piston (46) moves inside it.

The drive hub (37) comprising discs (44) is engaged on the primary shaft (33).

The fixed housing (12) has two functions:

- it receives the 17-bar pressure,
- it forms the body for the lubricating and cooling pump (22 l/min, nominal pressure 0.4 bar).

This pump is supplied with oil from the centre housing via a 500-micrometre strainer, a pipe (17) located under the transmission and a second pipe (20).

The clutch assembly includes 5 discs and 5 plates.

The discs (44) are equipped with paper packing for optimum progressive application and quieter operation.

A washer (77) is fitted between the cover (39) and the latest plate (45).

#### Operation

##### Clutch engagement

When the clutch pedal is released, the hydraulic valve located on the right-hand side of the gearbox supplies a 17-bar pressure which moves the piston (46) which, in turn, presses the plates (45) against the discs (44) and the progressivity washer (77) in order to drive the primary shaft (33).

The valve controls the smooth action of clutch engagement and modulates the pressure applied on the piston. The washer (77) ensures the progressivity of the clutch.

##### Clutch release

When pressure is no longer applied, the piston (46) is pushed back by the spring (42) and the plates (45) are no longer in contact with the discs and the washer (77) is released.

The lubricating and cooling flowrate for the discs is cut off in the released position in order to avoid driving the discs by the «drag» effect. For the same reason, the discs have a bulged face to allow easier disengagement.

#### List of parts

(1) O-ring	(21) Spacer housing	(42) Spring	(63) O-ring
(2) Anti-extrusion rings	(22) Bolt	(43) Circlip	(64) Union
(3) Splined ring	(23) Clutch housing	(44) Discs	(65) Pipe
(4) Locking ring	(24) Dowel	(45) Plates	(66) Union
(5) Bolt	(25) Flange	(46) Piston	(67) Diagnostic connector
(6) Washer	(26) Bolt	(47) Clutch assembly	(68) Valve, 1.5 bar
(7) Input shaft	(27) Dust guard	(48) Seal	(69) O-ring
(8) Seal	(28) O-ring	(49) Seal	(70) Pipe
(9) Shim(s)	(29) O-ring	(50) Bearing	(71) O-ring
(10) Pipe	(30) Suction unit	(51) Bush	(72) Union
(11) Pump cover	(31) Bolt	(52) Oil seals	(73) Clutch supply pipe
(12) Pump body	(32) PTO shaft	(53) Lubricating pump	(74) Plug
(13) Dynashift cover	(33) Primary shaft	(54) Bolt	(75) Bolt
(14) O-ring	(34) Circlip	(55) Bearing	(76) Dynashift supply pipe
(15) O-rings	(35) Washer	(56) Circlip	pipe
(16) Spacer	(36) Bearing	(57) Oil seal	(77) Progressivity washer
(17) Pipe	(37) Drive hub	(58) Circlip	(78) Spacers
(18) Bolt	(38) Bolt	(59) Circlip	
(19) Flange	(39) Cover	(60) Bolt	
(20) Pipe	(40) Bearing	(61) Cover	
	(41) Support	(62) Strainer	

### VISIBLE-RESULTS



**Clutch - Pressure-loaded**



4A01.3

Overall view

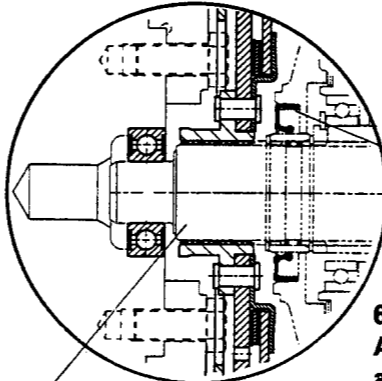
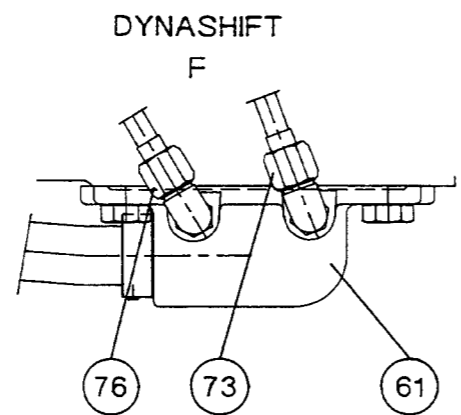
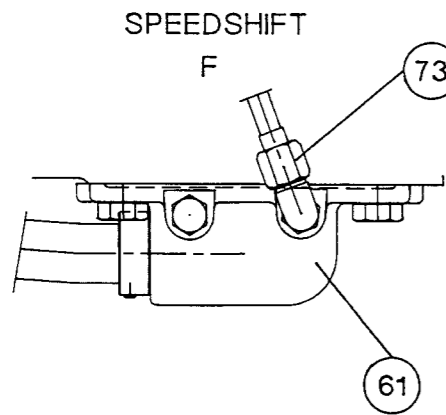
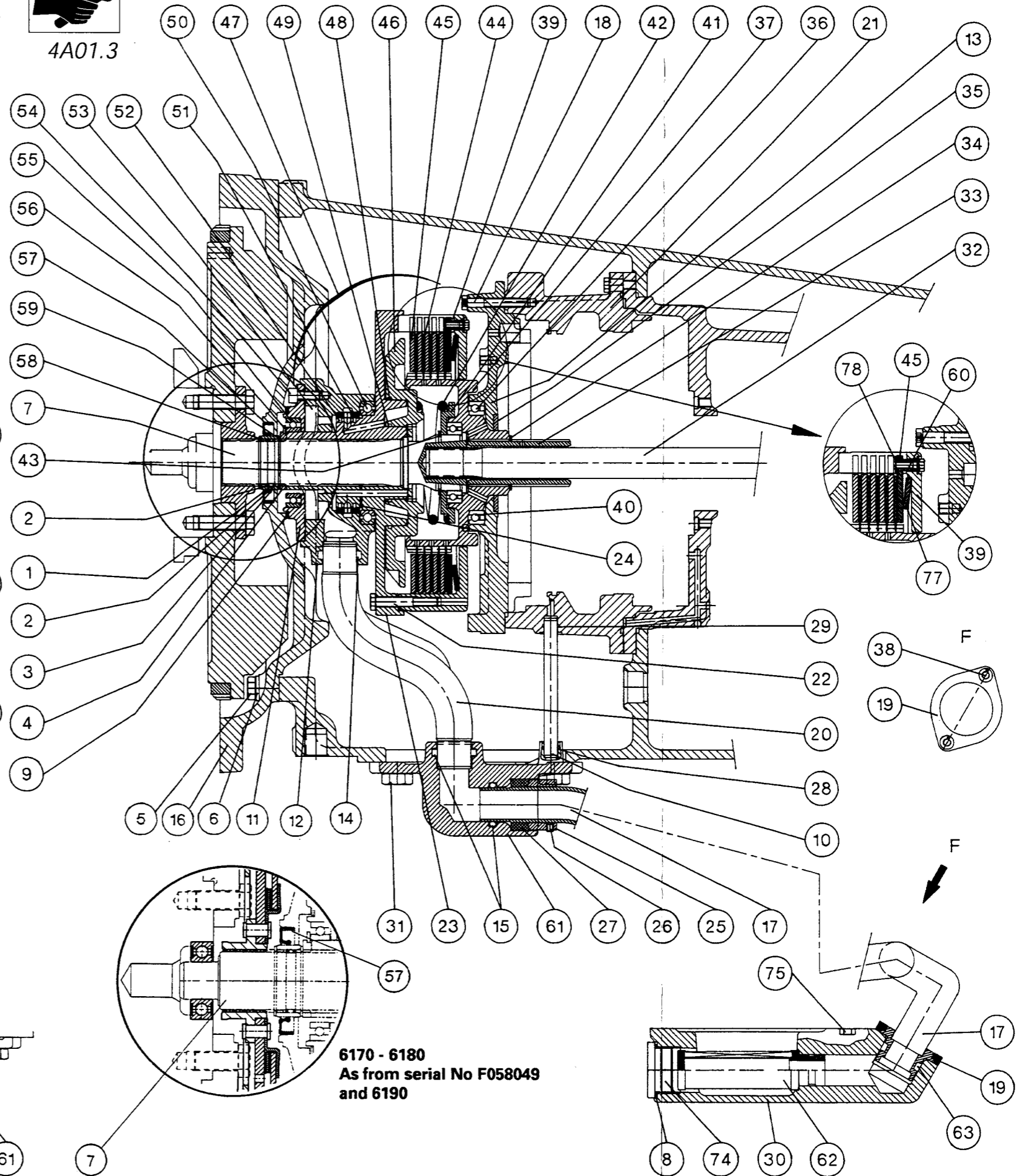
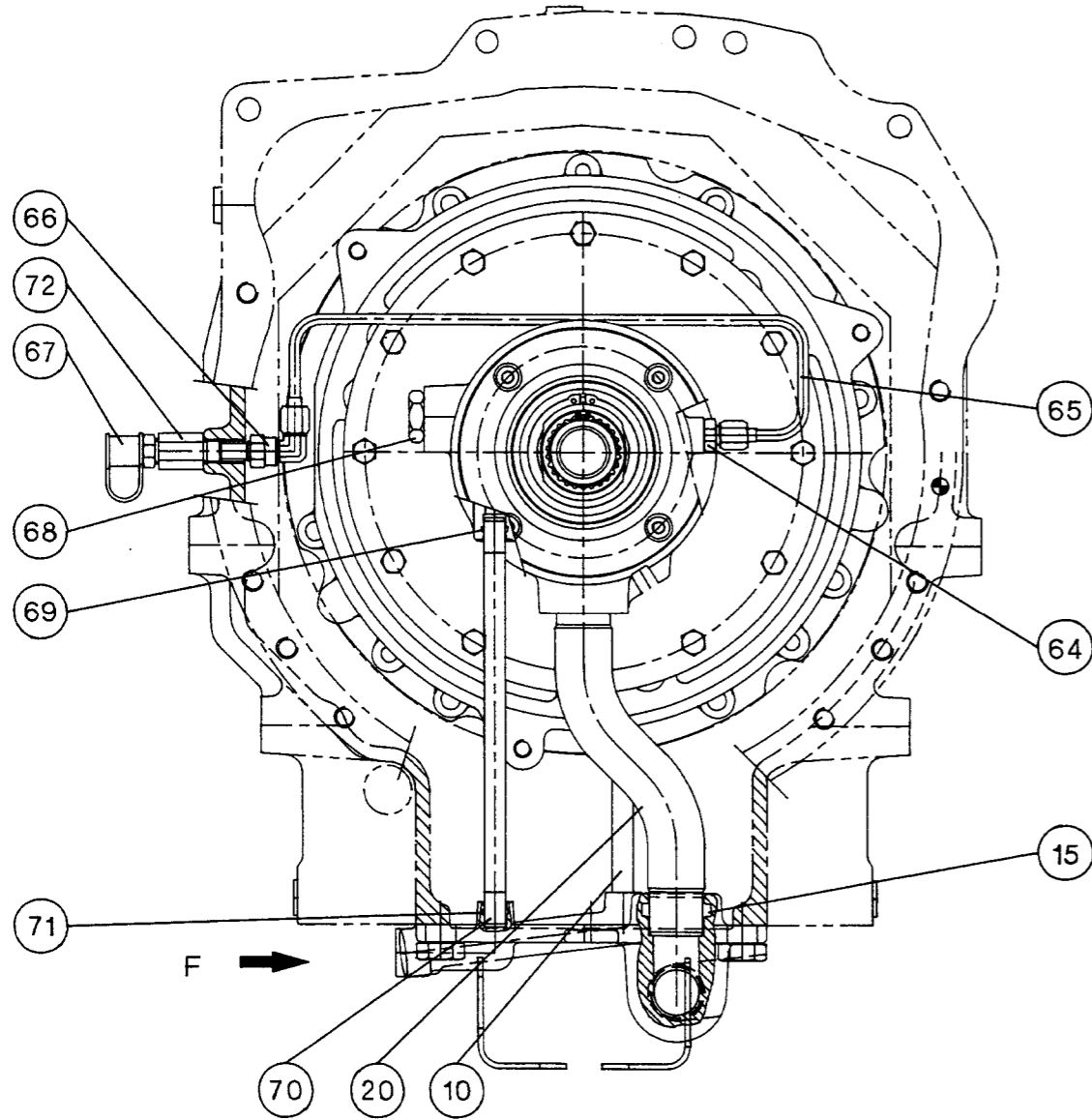

6170 - 6180  
As from serial No F058049  
and 6190

**VISIBLE-RESULTS**



4A01.4

6100 SERIES TRACTORS



# Clutch - Pressure-loaded

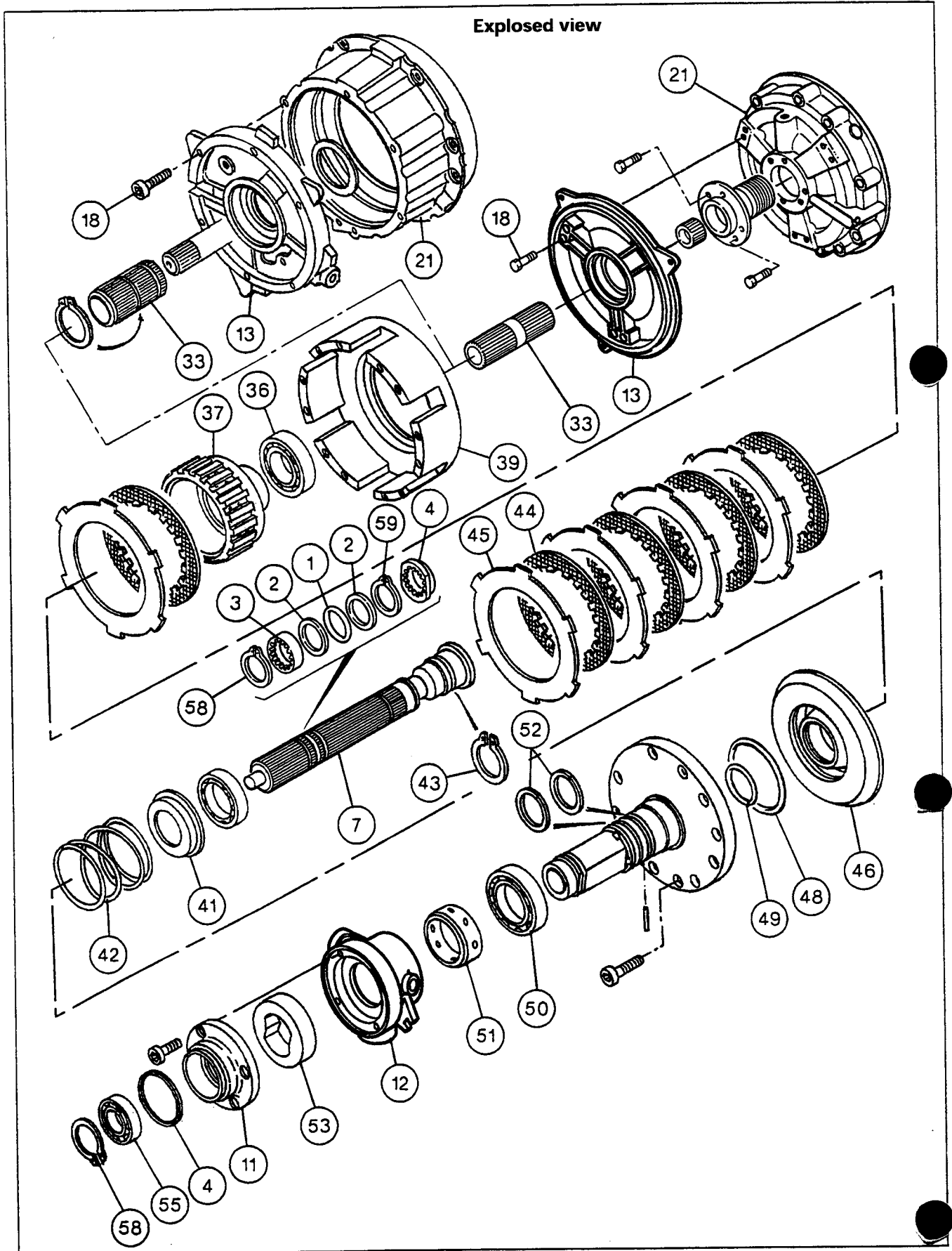

**VISIBLE-RESULTS**

**Clutch - Pressure-loaded****A. Removing and refitting oil seal (57) and O-ring (1)****Removal**

1. Split the tractor between the engine and the gearbox (see section 2 A01).
2. Drain the oil from the gearbox.
3. Remove the spacer (16) (see Section 3 C02).
4. Take off the circlip (58) and remove the splined bush (3), bushes (2) and O-ring (1).
5. Extract the oil seal (57).

**Refitting**

6. Fit the oil seal (57) with a suitable fixture.
7. Place the O-ring (1) between bushes (2). Reinstall the splined bush (3). Replace the circlip (58) and position it correctly in the recess.
8. Check that the shims (9) are in place.
9. Replace the spacer (see Section 3 C02).
10. Top up the oil in the centre housing.
11. Recouple the tractor between the engine and the gearbox.

**B. Removing, refitting and shimming the clutch****Removal**

12. Split the tractor between the engine and the gearbox (see Section 2 A01).
13. Drain the oil from the gearbox and rear axle.
14. Remove the spacer (see section 3 C02).
15. Remove the pipes (73) and (76), detach the cover (61), remove the flange (19) and the pipe (17).
16. Remove the clutch assembly (47) using a locally manufactured tool (Fig. 2).
17. Remove the PTO shaft (32).

**Refitting**

18. Replace O-rings (14) and (69).

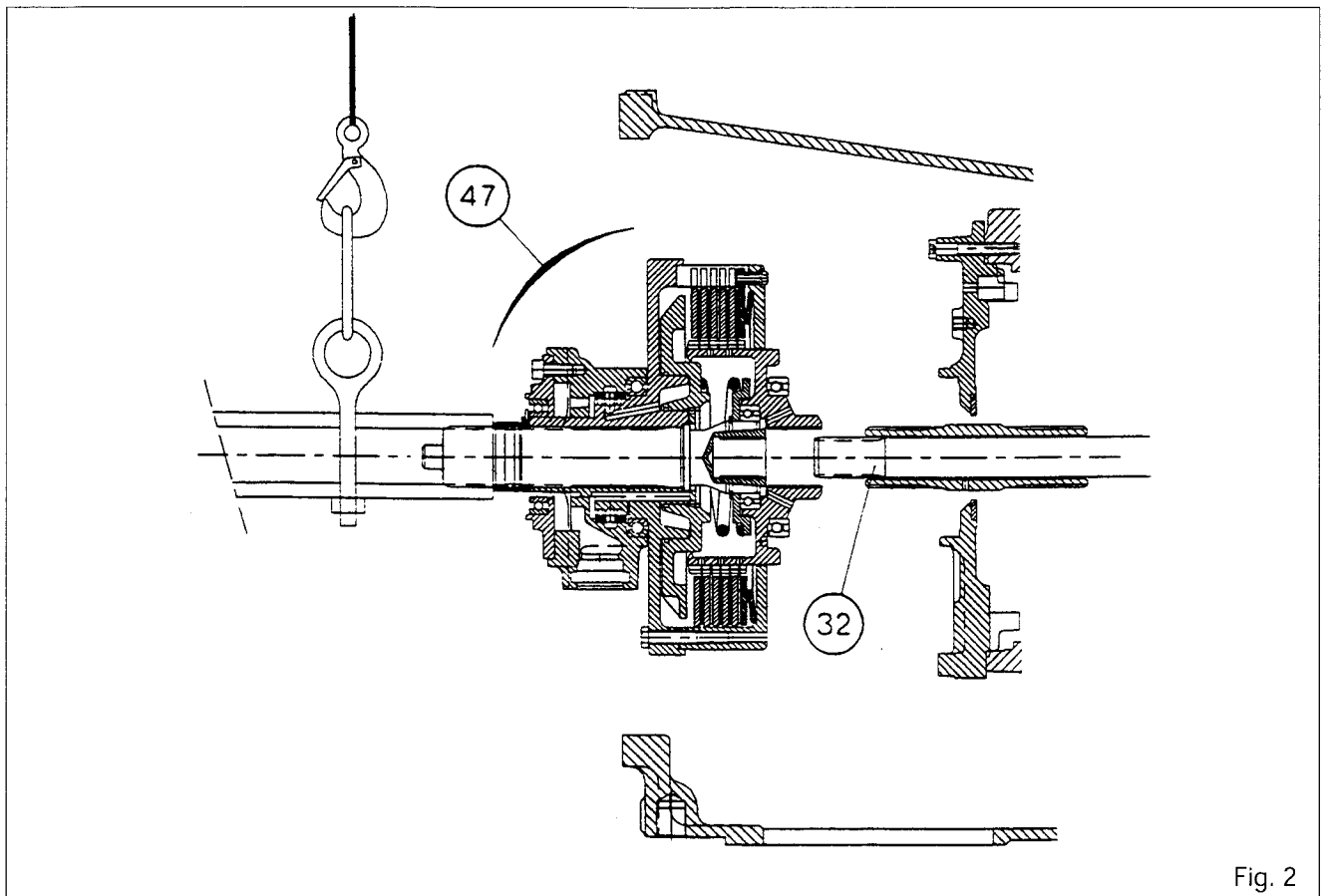

Fig. 2

**Thank you very much  
for your reading.**

**Please Click Here**

**Then            Get            More  
Information.**