

SCOTTS LAWN TRACTORS



TECHNICAL MANUAL

TM1776 (21Nov00)
Replaces TM1776 (29Feb00)

Litho in English



Scotts Lawn Tractor

**S1642, S1742, S2046 and
S2546 Limited Edition**

This technical manual is written for an experienced technician and contains sections that are specifically for this product. It is a part of a total product support program.

The manual is organized so that all the information on a particular system is kept together. The order of grouping is as follows:

- Table of Contents
- Specifications
- Component Location
- System Schematic
- Theory of Operation
- Troubleshooting Chart
- Diagnostics
- Tests & Adjustments
- Repair

Note: Depending on the particular section or system being covered, not all of the above groups may be used.

Each section will be identified with a symbol rather than a number. The groups and pages within a section will be consecutively numbered.

We appreciate your input on this manual. If you find any errors, or want to comment on the layout of the manual, please mail your comments back to us.

All information, illustrations and specifications in this manual are based on the latest information available at the time of publication. The right is reserved to make changes at any time without notice.

COPYRIGHT® 2000
Deere and Co.
John Deere Worldwide Commercial and
Consumer Equipment Division
Horicon, WI
All rights reserved

Safety



Specifications and Information



Engine—Briggs & Stratton



Engine—Kohler



Engine—Briggs & Stratton V-Twin



Electrical System



Gear Power Train



Hydrostatic Power Train K51



Steering



Attachments



Miscellaneous





SAFETY

RECOGNIZE SAFETY INFORMATION

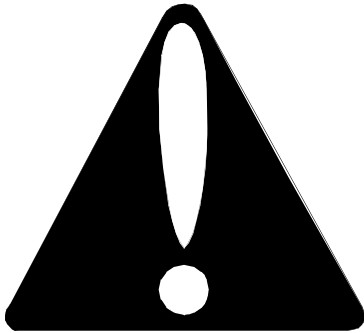

This is the safety-alert symbol. When you see this symbol on your machine or in this manual, be alert to the potential for personal injury.

Follow recommended precautions and safe servicing practices.

Understand Signal Words

A signal word—DANGER, WARNING, or CAUTION—is used with the safety-alert symbol. DANGER identifies the most serious hazards.

DANGER or WARNING safety signs are located near specific hazards. General precautions are listed on CAUTION safety signs. CAUTION also calls attention to safety messages in this manual.

REPLACE SAFETY SIGNS



Replace missing or damaged safety signs. See the machine operator's manual for correct safety sign placement.

HANDLE FLUIDS SAFELY-AVOID FIRES

Be Prepared For Emergencies

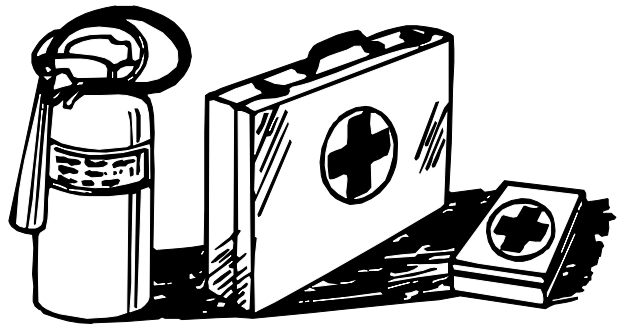
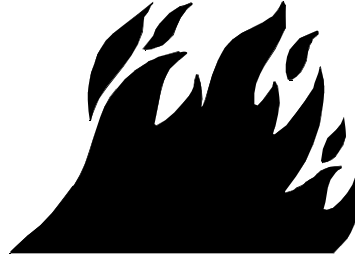

When you work around fuel, do not smoke or work near heaters or other fire hazards.

Store flammable fluids away from fire hazards. Do not incinerate or puncture pressurized containers.

Make sure machine is clean of trash, grease, and debris.

Do not store oily rags; they can ignite and burn spontaneously.

Be prepared if a fire starts.

Keep a first aid kit and fire extinguisher handy.

Keep emergency numbers for doctors, ambulance service, hospital, and fire department near your telephone.

USE CARE IN HANDLING AND SERVICING BATTERIES

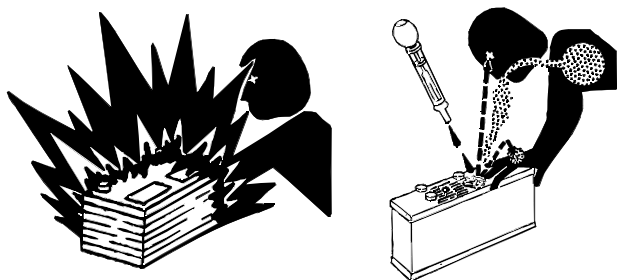

Prevent Battery Explosions

- Keep sparks, lighted matches, and open flame away from the top of battery. Battery gas can explode.
- Never check battery charge by placing a metal object across the posts. Use a volt-meter or hydrometer.
- Do not charge a frozen battery; it may explode. Warm battery to 16°C (60°F).

Prevent Acid Burns

- Sulfuric acid in battery electrolyte is poisonous. It is strong enough to burn skin, eat holes in clothing, and cause blindness if splashed into eyes.
- **Avoid acid burns by:**
 1. Filling batteries in a well-ventilated area.
 2. Wearing eye protection and rubber gloves.
 3. Avoiding breathing fumes when electrolyte is added.
 4. Avoiding spilling or dripping electrolyte.
 5. Use proper jump start procedure.
- **If you spill acid on yourself:**
 1. Flush your skin with water.
 2. Apply baking soda or lime to help neutralize the acid.
 3. Flush your eyes with water for 10-15 minutes.
 4. Get medical attention immediately.
- **If acid is swallowed:**
 1. Drink large amounts of water or milk.
 2. Then drink milk of magnesia, beaten eggs, or vegetable oil.
 3. Get medical attention immediately.

USE SAFE SERVICE PROCEDURES

Wear Protective Clothing

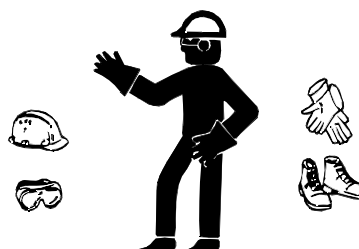

Wear close fitting clothing and safety equipment appropriate to the job.

Prolonged exposure to loud noise can cause impairment or loss of hearing. Wear a suitable hearing protective device such as earmuffs or earplugs to protect against objectionable or uncomfortable loud noises.

Operating equipment safely requires the full attention of the operator. Do not wear radio or music headphones while operating machine.

Service Machines Safely

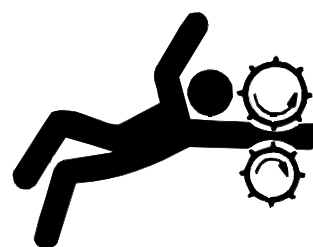

Tie long hair behind your head. Do not wear a necktie, scarf, loose clothing, or necklace when you work near machine tools or moving parts. If these items were to get caught, severe injury could result.

Remove rings and other jewelry to prevent electrical shorts and entanglement in moving parts.

Use Proper Tools

Use tools appropriate to the work. Makeshift tools and procedures can create safety hazards. Use power tools only to loosen threaded parts and fasteners. For loosening and tightening hardware, use the correct size tools. **DO NOT** use U.S. measurement tools on metric fasteners. Avoid bodily injury caused by slipping wrenches. Use only service parts meeting John Deere specifications.



Park Machine Safely

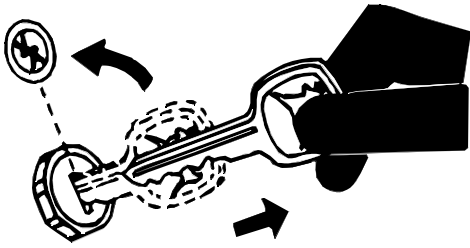

Before working on the machine:

1. Lower all equipment to the ground.
2. Stop the engine and remove the key.
3. Disconnect the battery ground strap.
4. Hang a "DO NOT OPERATE" tag in operator station.

Support Machine Properly And Use Proper Lifting Equipment

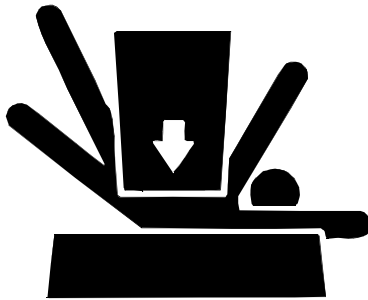

If you must work on a lifted machine or attachment, securely support the machine or attachment.

Do not support the machine on cinder blocks, hollow tiles, or props that may crumble under continuous load. Do not work under a machine that is supported solely by a jack. Follow recommended procedures in this manual.

Lifting heavy components incorrectly can cause severe injury or machine damage. Follow recommended procedure for removal and installation of components in the manual.

Work In Clean Area

Before starting a job:

1. Clean work area and machine.
2. Make sure you have all necessary tools to do your job.
3. Have the right parts on hand.
4. Read all instructions thoroughly; do not attempt shortcuts.

Using High Pressure Washers

Directing pressurized water at electronic/electrical components or connectors, bearings, hydraulic seals, fuel injection pumps or other sensitive parts and components may cause product malfunctions. Reduce pressure and spray at a 45 to 90 degree angle.

Illuminate Work Area Safely

Illuminate your work area adequately but safely. Use a portable safety light for working inside or under the machine. Make sure the bulb is enclosed by a wire cage. The hot filament of an accidentally broken bulb can ignite spilled fuel or oil.

Work In Ventilated Area

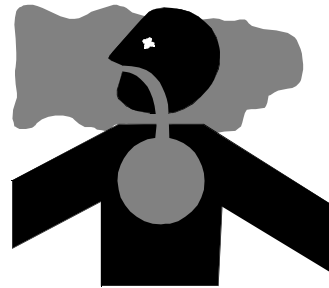

Engine exhaust fumes can cause sickness or death. If it is necessary to run an engine in an enclosed area, remove the exhaust fumes from the area with an exhaust pipe extension.

If you do not have an exhaust pipe extension, open the doors and get outside air into the area.

WARNING: California Proposition 65

Warning:

Diesel engine exhaust and some of its constituents are known to the State of California to cause cancer, birth defects, and other reproductive harm.

Gasoline engine exhaust from this product contains chemicals known to the State of California to cause cancer, birth defects, or other reproductive harm.

Remove Paint Before Welding Or Heating

Avoid potentially toxic fumes and dust. Hazardous fumes can be generated when paint is heated by welding, soldering, or using a torch. Do all work outside or in a well ventilated area. Dispose of paint and solvent properly. Remove paint before welding or heating: If you sand or grind paint, avoid breathing the dust. Wear an approved respirator. If you use solvent or paint stripper, remove stripper with soap and water before welding. Remove solvent or paint stripper containers and other flammable material from area. Allow fumes to disperse at least 15 minutes before welding or heating.

Avoid Harmful Asbestos Dust

Avoid breathing dust that may be generated when handling components containing asbestos fibers. Inhaled asbestos fibers may cause lung cancer.

Components in products that may contain asbestos fibers are brake pads, brake band and lining assemblies, clutch plates, and some gaskets. The asbestos used in these components is usually found in a resin or sealed in some way. Normal handling is not hazardous as long as airborne dust containing asbestos is not generated.

Avoid creating dust. Never use compressed air for cleaning. Avoid brushing or grinding material containing asbestos. When servicing, wear an approved respirator. A special vacuum cleaner is recommended to clean asbestos. If not available, apply a mist of oil or water on the material containing asbestos. Keep bystanders away from the area.

SERVICE TIRES SAFELY



Explosive separation of a tire and rim parts can cause serious injury or death.

Do not attempt to mount a tire unless you have the proper equipment and experience to perform the job. Always maintain the correct tire pressure. Do not inflate the tires above the recommended pressure. Never weld or heat a wheel and tire assembly. The heat can cause an increase in air pressure resulting in a tire explosion. Welding can structurally weaken or deform the wheel.

When inflating tires, use a clip-on chuck and extension hose long enough to allow you to stand to one side and NOT in front of or over the tire assembly. Use a safety cage if available.

Check wheels for low pressure, cuts, bubbles, damaged rims or missing lug bolts and nuts.

AVOID INJURY FROM ROTATING BLADES, AUGERS AND PTO SHAFTS

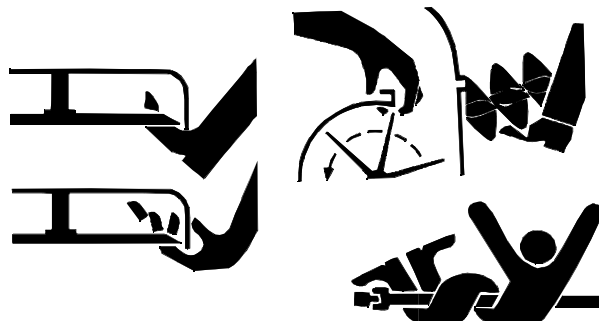

Keep hands and feet away while machine is running. Shut off power to service, lubricate or remove mower blades, augers or PTO shafts.

SERVICE COOLING SYSTEM SAFELY



Explosive release of fluids from pressurized cooling system can cause serious burns.

Shut off machine. Only remove filler cap when cool enough to touch with bare hands. Slowly loosen cap to first stop to relieve pressure before removing completely.



HANDLE CHEMICAL PRODUCTS SAFELY

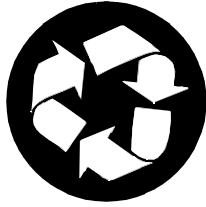
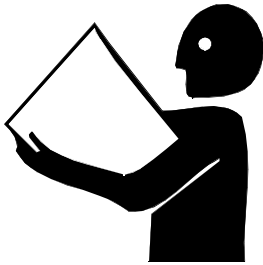

Direct exposure to hazardous chemicals can cause serious injury. Potentially hazardous chemicals used with John Deere equipment include such items as lubricants, coolants, paints, and adhesives.

A Material Safety Data Sheet (MSDS) provides specific details on chemical products: physical and health hazards, safety procedures, and emergency response techniques. Check the MSDS before you start any job using a hazardous chemical. That way you will know exactly what the risks are and how to do the job safely. Then follow procedures and recommended equipment.

Dispose of Waste Properly

Improperly disposing of waste can threaten the environment and ecology. Potentially harmful waste used with John Deere equipment include such items as oil, fuel, coolant, brake fluid, filters, and batteries. Use leakproof containers when draining fluids. Do not use food or beverage containers that may mislead someone into drinking from them. Do not pour waste onto the ground, down a drain, or into any water source. Inquire on the proper way to recycle or dispose of waste from your local environmental or recycling center, or from your John Deere dealer.

LIVE WITH SAFETY



Before returning machine to customer, make sure machine is functioning properly, especially the safety systems. Install all guards and shields.

CONTENTS

	Page
SPECIFICATIONS	3
INCH TORQUE VALUES	8
METRIC TORQUE VALUES	9
GASOLINE SPECIFICATIONS	10
GASOLINE STORAGE	10
LUBRICANT SPECIFICATIONS	10
ENGINE OIL	10
GREASE	11
ALTERNATIVE LUBRICANTS	11
SYNTHETIC LUBRICANTS	11
OIL FILTERS	11
LUBRICANT STORAGE	11
SERIAL NUMBER LOCATIONS	12
TRACTOR IDENTIFICATION NUMBER	12
ENGINE SERIAL NUMBER	12
GEAR TRANSAXLE SERIAL NUMBER	12
HYDROSTATIC TRANSAXLE SERIAL NUMBER	12



Engine (Briggs & Stratton V-Twin):

20 HP:

Make	Briggs & Stratton
Style	Vertical Shaft
Model (V-Twin).....	407777
Power	14.91 kW (20.0 hp)
Displacement	656 cm ³ (40.0 cu-in.)
Type.....	Gasoline, Air Cooled, V-Twin Cylinder, 4-Cycle
Bore.....	75.4 mm (2.968 in.)
Stroke	73.4 mm (2.89 in.)
Valves	Overhead Valves
Lubrication.....	Pressurized
Oil Filter.....	Full Flow Filter (w/o By-Pass Valve)
Crankcase Oil Capacity:	
without oil filter.....	1.8 L (1.9 qt)
with oil filter	1.9 L (2.0 qt)
Oil: Warm Climate (Above 40°F)	SE, SF, SG, SAE 30W
Cold Climate (Below 40°F).....	SE, SF, SG, SAE 10W30
Ignition System	Magnetron [®] Magneto Ignition
Magneto Air Gap.....	0.20 – 0.30 mm (0.008 – 0.012 in.)
Spark Plugs.....	M78543 (Champion RC-12 YC)
Spark Plug Air Gap	0.76 mm (0.030 in.)
Starter Type.....	Bendix Inertia Drive
Fuel Shutoff Solenoid	Replaceable (Below Carburetor Float Bowl)

25 HP:

Make	Briggs and Stratton
Style	Vertical Shaft
Model (V-Twin).....	445777
Power	18.64 kW (25.0 hp)
Displacement	724 cm ³ (44.2 cu-in.)
Type.....	Gasoline, Air Cooled, V-Twin Cylinder, 4-Cycle
Lubrication.....	Fully Pressurized
Oil Filter.....	Single Element, Full Flow, Spin-On Filter
Crankcase Oil Capacity:	
without oil filter.....	1.8 L (1.9 qt)
with oil filter	1.9 L (2.0 qt)
Oil: Warm Climate (Above 40°F)	SE, SF, SG, SAE 30W
Cold Climate (Below 40°F).....	SE, SF, SG, SAE 10W30
Ignition System	Magnetron [®] Magneto Ignition
Magneto Air Gap.....	0.20 – 0.30 mm (0.008 – 0.012 in.)
Charging System.....	Dual Circuit (AC/DC)
Charging Capacity.....	2 – 4 amps, 14 volts DC@3350 rpm (Unregulated)
Spark Plugs.....	M78543 (Champion RC-12 YC)
Spark Plug Air Gap	0.76 mm (0.030 in.)
Starter Type.....	Bendix Inertia Drive
Fuel Shutoff Solenoid	Replaceable (Below Carburetor Float Bowl)

Brakes

Location.....	Transaxle
Type:	
Gear Transaxle	Single, External Brake Disc With Dual Friction Pucks
Hydrostatic Transaxle	Single, Internal Brake Disc

Traction Drive Belt:

Gear	
New Belt Length	2686 ± 8 mm (105.75 ± 0.3 in.)
Minimum Effective Length	2656 mm (104.57 in.)
Maximum Effective Length	2736 mm (107.72 in.)
Hydro—K51 Transmission	
New Belt Length (Hand Control)	2435 ± 8 mm (95.87 ± 0.3 in.)
New Belt Length (Foot Control)	2450 ± 8 mm (96.46 ± 0.3 in.)



Gear Transaxle

Make	Dana
Model	Spicer H-D 4360 Transaxle
Type	Five-Speed/Linear Shift
Domestic Ground Speeds (at FAST idle—2950 rpm) and Gear Ratios:	
1st Gear	2.4 km/hr (1.5 mph)
2nd Gear	3.2 km/hr (2.0 mph)
3rd Gear	5.0 km/hr (3.1 mph)
4th Gear	6.4 km/hr (4.0 mph)
5th Gear	8.0 km/hr (5.0 mph)
Reverse	3.7 km/hr (2.3 mph)
Lubrication—Input Shaft Needle Bearings	Unirex® N3 Grease Only (M120263)
Lubrication—Transaxle	Shell Darina® D Grease Only (AM119608)
Capacity—Transaxle	0.64 kg (1.406 lbs)

Hydro Transaxle K51

Make	Kanzaki
Model	Tuff Torq® K-51 Transaxle
Type	Hydrostatic
Ground Speeds (at FAST idle—2950 rpm):	
Forward	0 – 8.5 km/hr (0 – 5.3 mph)
Reverse	0 – 4.7 km/hr (0 – 2.9 mph)
Lubrication	10W30 Engine Oil, Class CD
Reservoir	Internal
Capacity	2.5 L (2.4 qt)

Chassis:

Wheelbase	1178.2 mm (46.39 in.)
Overall Length	1524 mm (60 in.)
Overall Width (W/O Mower Deck)	908 mm (35.75 in.)
Height	980 mm (38.6 in.)
Average Overall Weight 42 inch (With Mower Deck, No Fuel)	185.52 kg (409 lbs)
Average Overall Weight 46 inch (With Mower Deck, No Fuel)	191.42 kg (422 lbs)
Hitch Capacity—	
Trailer Load Maximum	136 kg (300 lbs)
Trailer Tongue Weight Maximum	22.6 kg (50 lbs)

Electrical:

Battery Type	BCI Group, U1
Battery Cranking Amps	230 amps at 0° C (32° F)
Battery Cold Cranking Amps	190 amps at 0° C (32° F)
Battery Specific Gravity	Above 1.225 Points
Headlight Bulbs	Type 1156, 12 Volt

Fuel/Air System:

Carburetor Type Side Draft
 Throttle/Choke Unitized Control Linkage
 Carburetor Fuel Shut-Off Solenoid Electric
 Fuel Delivery Gravity Flow
 Fuel Filter Replaceable In-line type
 Fuel Type Unleaded (87 Octane Minimum)
 Fuel Tank Capacity 4.7 L (1.25 gal)
 Air Filter Paper Element with Foam Pre-cleaner
 Muffler Anti-Backfire Horizontal Discharge Below Frame

Steering:

Type Manual—Pinion/Sector
 Axle Pivot Hub Shim Adjustable
 Lubrication Multipurpose Grease
 Lubrication Interval 10 hrs (Maximum)
 Toe-In 6 mm (0.24 in.) — Non-Adjustable
 Turning Radius 584 mm (23 in.)

Wheels:

Size—
 Front 6.0 x 4.50
 Rear 8.0 x 6.18

Tires:

Size—
 Front 13 x 6.50—6 NHS (2 ply)
 Rear 18 x 9.50—8 NHS (2 ply)
 Pressure—
 Front (with mower deck) 97 kPa (14 psi)
 Rear (with mower deck) 69 kPa (10 psi)

PTO Drive

Type V-Belt
 Clutch Type Manual Belt Tensioning
 Control Location Lever on dash

Mower Deck Drive Belt

42-Inch Deck (Single Cylinder Engine)—
 Actual effective length 2920 ± 10 mm (115.03 ± 0.4 in.)
 42-Inch Deck (V-Twin Engine)—
 Actual effective length 3921.8 ± 10 mm (154.40 ± 0.4 in.)
 46-Inch Deck (Single Cylinder Engine)—
 Actual effective length 3665 ± 10 mm (144.29 ± 0.4 in.)
 46-Inch Deck (V-Twin Engine)—
 Actual effective length 3640 ± 10 mm (143.10 ± 0.4 in.)
 48-Inch Deck (V-Twin Engine)—
 Actual effective length 3565 ± 10 mm (140.37 ± 0.4 in.)

Mower Deck:

42-Inch Mower Deck—

Type	Rotary—Dual Spindles (Non-Serviceable)
Cutting Blade	Two—57 x 4 x 545 mm (2.25 x 0.16 x 21.4 in.)
Blade Cutting Edge	30 ± 5° Angle
Blade Wing Lift/Height	22 ± 2 mm (0.87 ± 0.08 in.)
Overall Cutting Width	1066 mm (42 in.)
Drive Type	Single V-Belt (With Spring Tension Idler)
Spindle Lubrication	None—Sealed Bearings
Lift Type	Manual—Operator’s Station
Cutting Settings	Seven: 25.4 – 101.6 mm (1.0 – 4.0 in.)

46-Inch Mower Deck—

Type	Rotary—Triple Spindles (Non-Serviceable)
Cutting Blade	Three—50.8 x 5 x 407.4 mm (2 x 0.2 x 16 in.)
Blade Cutting Edge	30 ± 5° Angle
Blade Wing Lift/Height	20.3 ± 3 mm (0.8 ± 0.12 in.)
Overall Cutting Width	1168.4 mm (46 in.)
Drive Type	Single V-Belt (With Spring Tension Idler)
Spindle Lubrication	None—Sealed Bearings
Lift Type	Manual—Operator’s Station
Cutting Settings	Seven: 25.4 – 101.6 mm (1.0 – 4.0 in.)

48-Inch Mower Deck—

Type	Rotary—Triple Spindles (Non-Serviceable)
Cutting Blade (Standard) ¹	Three—53.5 x 4.1 x 430 mm (2.1 x 0.16 x 16.93 in.)
Blade Cutting Edge	30 ± 5° Angle
Blade Wing Lift/Height	24.4 ± 2 mm (0.96 ± 0.08 in.)
Overall Cutting Width	1219 mm (48 in.)
Drive Type	Single V-Belt (With Spring Tension Idler)
Spindle Lubrication	None—Sealed Bearings
Lift Type	Manual—Operator’s Station
Cutting Settings	Seven: 25.4 – 101.6 mm (1.0 – 4.0 in.)

Implement Lift











Lift System	Manual with Lift-Assist Spring
Lift Lever Location	Front of Seat between Legs



1. Optional bagging blades available.

INCH TORQUE VALUES



SAE Grade and Head Markings	1 or 2 ^b No Marks 	5  5.1  5.2 	8  8.2 
	2 No Marks 	5  	8  

Size	Grade 1				Grade 2 ^b				Grade 5, 5.1 or 5.2				Grade 8 or 8.2			
	Lubricated ^a		Dry ^a		Lubricated ^a		Dry ^a		Lubricated ^a		Dry ^a		Lubricated ^a		Dry ^a	
	Nm	lb-ft	Nm	lb-ft	Nm	lb-ft	Nm	lb-ft	Nm	lb-ft	Nm	lb-ft	Nm	lb-ft	Nm	lb-ft
1/4	3.8	2.8	4.7	3.5	6	4.4	7.5	5.5	9.5	7	12	9	13.5	10	17	12.5
5/16	7.7	5.7	9.8	7.2	12	9	15.5	11.5	19.5	14.5	25	18.5	28	20.5	35	26
3/8	13.5	10	17.5	13	22	16	27.5	20	35	26	44	32.5	49	36	63	46
7/16	22	16	28	20.5	35	26	44	32.5	56	41	70	52	80	59	100	74
1/2	34	25	42	31	53	39	67	49	85	63	110	80	120	88	155	115
9/16	48	35.5	60	45	76	56	95	70	125	92	155	115	175	130	220	165
5/8	67	49	85	63	105	77	135	100	170	125	215	160	240	175	305	225
3/4	120	88	150	110	190	140	240	175	300	220	380	280	425	315	540	400
7/8	190	140	240	175	190	140	240	175	490	360	615	455	690	510	870	640
1	285	210	360	265	285	210	360	265	730	540	920	680	1030	760	1300	960
1-1/8	400	300	510	375	400	300	510	375	910	670	1150	850	1450	1075	1850	1350
1-1/4	570	420	725	535	570	420	725	535	1280	945	1630	1200	2050	1500	2600	1920
1-3/8	750	550	950	700	750	550	950	700	1700	1250	2140	1580	2700	2000	3400	2500
1-1/2	990	730	1250	930	990	730	1250	930	2250	1650	2850	2100	3600	2650	4550	3350

DO NOT use these values if a different torque value or tightening procedure is given for a specific application. Torque values listed are for general use only. Check tightness of fasteners periodically.

Shear bolts are designed to fail under predetermined loads. Always replace shear bolts with identical grade.

Fasteners should be replaced with the same or higher grade. If higher grade fasteners are used, these should only be tightened to the strength of the original.

Make sure fasteners threads are clean and that you properly start thread engagement. This will prevent them from failing when tightening.

Tighten plastic insert or crimped steel-type lock nuts to approximately 50 percent of the dry torque shown in the chart, applied to the nut, not to the bolt head.

Tighten toothed or serrated-type lock nuts to the full torque value.

^a "Lubricated" means coated with a lubricant such as engine oil, or fasteners with phosphate and oil coatings.

"Dry" means plain or zinc plated without any lubrication.

^b Grade 2 applies for hex cap screws (not hex bolts) up to 152 mm (6 in.) long. Grade 1 applies for hex cap screws over 152 mm (6 in.) long, and for all other types of bolts and screws of any length.

METRIC TORQUE VALUES



Property Class and Head Markings	4.8	8.8	9.8	10.9	12.9
Property Class and Nut Markings	5	10	10	12	

Size	Class 4.8				Class 8.8 or 9.8				Class 10.9				Class 12.9			
	Lubricated ^a		Dry ^a		Lubricated ^a		Dry ^a		Lubricated ^a		Dry ^a		Lubricated ^a		Dry ^a	
	Nm	lb-ft	Nm	lb-ft	Nm	lb-ft	Nm	lb-ft	Nm	lb-ft	Nm	lb-ft	Nm	lb-ft	Nm	lb-ft
M6	4.7	3.5	6	4.4	9	6.6	11.5	8.5	13	9.5	16.5	12.5	15.5	11.5	19.5	14.5
M8	11.5	8.5	14.5	10.7	22	16	28	20.5	32	23.5	40	29.5	37	27.5	47	35
M10	23	17	29	21	43	32	55	40	63	46	80	59	75	55	95	70
M12	40	29.5	50	37	75	55	95	70	110	80	140	105	130	95	165	120
M14	63	46	80	59	120	88	150	110	175	130	220	165	205	150	260	190
M16	100	74	125	92	190	140	240	175	275	200	350	225	320	235	400	300
M18	135	100	175	125	265	195	330	245	375	275	475	350	440	325	560	410
M20	190	140	245	180	375	275	475	350	530	390	675	500	625	460	790	580
M22	265	195	330	245	510	375	650	480	725	535	920	680	850	625	108	800
M24	330	245	425	315	650	480	820	600	920	680	115	850	108	800	135	100
M27	490	360	625	460	950	700	1200	885	1350	1000	1700	1250	1580	1160	200	1500
M30	660	490	850	625	1290	950	1630	1200	1850	1350	2300	1700	2140	1700	2700	2000
M33	900	665	1150	850	1750	1300	2200	1625	2500	1850	3150	2325	2900	2150	3700	2730
M36	1150	850	1450	1075	2250	1650	2850	2100	3200	2350	4050	3000	3750	2770	4750	3500

DO NOT use these values if a different torque value or tightening procedure is given for a specific application. Torque values listed are for general use only. Check tightness of fasteners periodically.

Shear bolts are designed to fail under predetermined loads. Always replace shear bolts with identical property class.

Fasteners should be replaced with the same or higher property class. If higher property class fasteners are used, these should only be tightened to the strength of the original.

Make sure fasteners threads are clean and that you properly start thread engagement. This will prevent them from failing when tightening.

Tighten plastic insert or crimped steel-type lock nuts to

approximately 50 percent of the dry torque shown in the chart, applied to the nut, not to the bolt head. Tighten toothed or serrated-type lock nuts to the full torque value.

^a "Lubricated" means coated with a lubricant such as engine oil, or fasteners with phosphate and oil coatings.

"Dry" means plain or zinc plated without any lubrication.

SERIAL NUMBER LOCATIONS

When working on machines or components that are covered by warranty, it is **IMPORTANT** that you include the tractor identification number and the component serial numbers on the warranty claim form.

The location of tractor identification number and component serial numbers are shown below.

TRACTOR IDENTIFICATION NUMBER

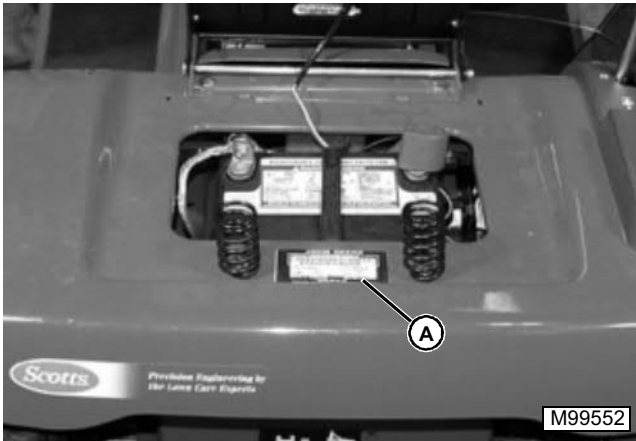

Tractor identification number plate (A) is located on the rear of frame or under seat.

ENGINE SERIAL NUMBER

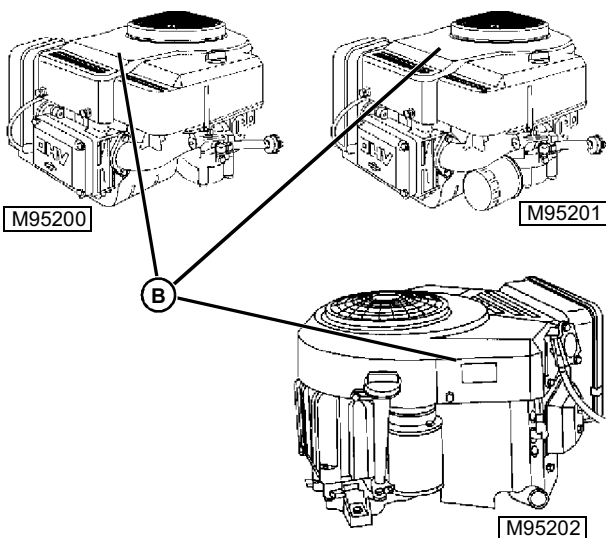

Tractor engine serial number sticker (B) is located on fan shroud.

GEAR TRANSAXLE SERIAL NUMBER

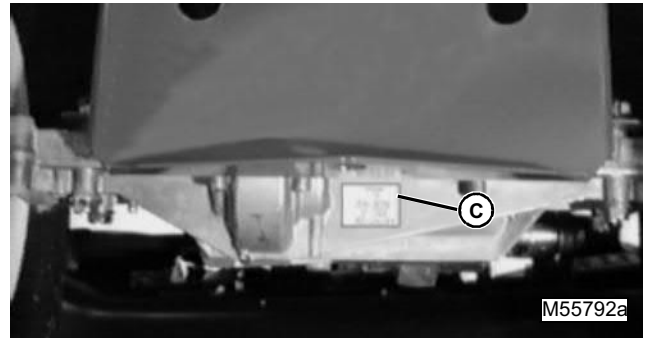

Gear transaxle serial number sticker (C) is on rear of housing.

HYDROSTATIC TRANSAXLE SERIAL NUMBER

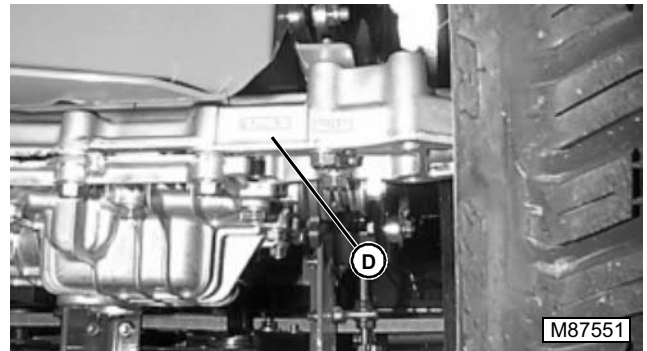

Serial number (D) is located on a bar coded label located on the right rear of the transaxle.

CONTENTS

	Page
SPECIFICATIONS	3
GENERAL SPECIFICATIONS	3
TESTS & ADJUSTMENTS SPECIFICATIONS	3
REPAIR SPECIFICATIONS	3
TORQUE SPECIFICATIONS (Alphabetical)	4
TROUBLESHOOTING	5
ENGINE TROUBLESHOOTING	7
TESTS AND ADJUSTMENTS	10
THROTTLE CABLE ADJUSTMENT	10
FUEL SHUTOFF SOLENOID TEST	10
GOVERNOR ADJUSTMENT - STATIC	11
GOVERNOR ADJUSTMENT - RUNNING	11
GOVERNOR IDLE ADJUSTMENT	12
SLOW IDLE CARBURETOR ADJUSTMENT	12
VALVE CLEARANCE ADJUSTMENT	13
ARMATURE AIR GAP ADJUSTMENT	14
FUEL & AIR REPAIR	14
UPPER BLOWER HOUSING REMOVAL & INSTALLATION	14
AIR CLEANER SERVICE	15
CARBURETOR REMOVAL & INSTALLATION	15
CARBURETOR DISASSEMBLY	16
CARBURETOR INSPECTION	17
CARBURETOR ASSEMBLY	18
BREATHER VALVE SERVICE	19
ENGINE REPAIR	20
ENGINE REMOVAL	20
ENGINE INSTALLATION	21
CYLINDER HEAD	22
CYLINDER HEAD INSPECTION & REPAIR	24
VALVES REMOVAL	24
VALVES REFACE	24
VALVES INSTALLATION	25
GOVERNOR REMOVAL & INSTALLATION	26
OIL PUMP REMOVAL & INSTALLATION	27
PISTON, RINGS & ROD	28
PISTON INSPECTION	30
CONNECTING ROD INSPECTION	30
CYLINDER BORE INSPECTION	32
CYLINDER BORE HONING	33
RESIZING CYLINDER BORE	33
CYLINDER BORE CLEANING	34
FLYWHEEL REMOVAL & INSTALLATION	34
CRANKSHAFT & CAM GEAR REMOVAL	35
CRANKSHAFT/CAM GEAR INSTALLATION	36



**Thank you very much for
your reading. Please Click
Here. Then Get COMPLETE
MANUAL. NO WAITING**



NOTE:

**If there is no response to
click on the link above,
please download the PDF
document first and then
click on it.**

Page

MAGNETO BEARING INSPECTION 37
CAM GEAR BEARING INSPECTION 38
PTO BEARING REMOVAL & INSTALLATION 39
STARTER REMOVAL & INSTALLATION 40
STARTER DISASSEMBLY 40
STARTER ASSEMBLY 42
STARTER PINION GEAR REPLACEMENT 44



SPECIFICATIONS

GENERAL SPECIFICATIONS

Make	Briggs & Stratton
Series	Intek™
Type	1036-E1 Gasoline
Model	311777
Horsepower	12.6 kW (17 hp)
Cylinders	1
Displacement	508 cm ³ (31.0 cu-in.)
Stroke/Cycle	4
Valves	Overhead Valves
Bore	90.6 mm (3.57 in.)
Stroke	77.8 mm (3.06 in.)
Crankcase Oil Capacity	
without oil filter	1.42 L (1.5 qt)
with oil filter	1.66 L (1.75 qt)
Cooling System	Air Cooled
Air Cleaner	Paper with outer foam element
Muffler	Horizontal discharge below frame
Aspiration	Normal
Fuel Filter	Replaceable (In-Line Type)



TESTS & ADJUSTMENTS SPECIFICATIONS

Valve Clearance	
Intake	0.08 – 0.13 mm (0.003 – 0.005 in.)
Exhaust	0.13 – 0.18 mm (0.005 – 0.007 in.)
Valve Guide Depth	0.12 – 0.15 mm (0.005 – 0.006 in.)
Slow Idle	1750 ± 100 rpm
Fast Idle	3300 ± 100 rpm
Magneto Air Gap	0.25 – 0.35 mm (0.010 – 0.014 in.)
Spark Plug Gap	0.76 mm (0.030 in.)

REPAIR SPECIFICATIONS

Cylinder Bore, Pistons and Rings:

Cylinder Bore Standard	
Maximum Dimension	90.75 mm (3.573 in.)
Minimum Dimension	90.68 mm (3.570 in.)
Cylinder Bore Out of Round (max)	0.04 mm (0.0015 in.)
Piston Pin (Wear Limit)	20.29 mm (0.799 in.)
Piston Pin Bore (Wear Limit)	20.35 mm (0.801 in.)
Ring End Gap (Wear Limit)	
Cast Iron Bore:	
Compression Ring (Top)	0.76 mm (0.030 in.)
Compression Ring (Center)	0.76 mm (0.030 in.)
Oil Ring	0.89 mm (0.035 in.)
Compression and Oil Ring Groove Wear Limit (New Ring Installed)	0.15 mm (0.006 in.)

Valves:

Valve Guide (Wear Limit)	6.09 mm (0.240 in.)
------------------------------------	---------------------

TORQUE SPECIFICATIONS (Alphabetical) ENGINES – Briggs & Stratton (Single Cylinder)

Valve Seat Width	0.79 – 1.98 mm (0.031 – 0.078 in.)
Valve Margin (Minimum)	0.40 mm (0.016 in.)
Valve Face Angle	45°
Valve Seat Narrowing Angle	30°

Connecting Rod and Crankshaft:

Connecting Rod Crankpin (Wear Limit)	31.80 mm (1.252 in.)
Connecting Rod Piston Pin Bearing (Wear Limit)	20.37 mm (0.802 in.)
Crankshaft PTO Journal (Wear Limit)	34.95 mm (1.376 in.)
Crankshaft Magneto Journal (Wear Limit)	34.95 mm (1.376 in.)
Magneto Bearing (Wear Limit)	35.13 mm (1.383 in.)
PTO Bearing (Wear Limit)	35.13 mm (1.383 in.)
Crankshaft Crankpin Journal (Wear Limit)	31.67 mm (1.247 in.)
Crankshaft End Play	0.05 – 0.58 mm (0.002 – 0.023 in.)
Cam Gear PTO Journal (Wear Limit)	12.65 mm (0.498 in.)
Cam Gear Magneto Journal (Wear Limit)	12.65 mm (0.498 in.)
Cam Lobe (Wear Limit)	30.07 mm (1.184 in.)
Cam Gear Bearing (Wear Limit)	12.8 mm (0.504 in.)

TORQUE SPECIFICATIONS (Alphabetical)

Air Cleaner Base to Carburetor	6.2 N•m (55 lb-in.)
Blower Housing Screws	6.2 N•m (55 lb-in.)
Carburetor to Intake Manifold	7.3 N•m (65 lb-in.)
Carburetor Bowl Screw	4.5 N•m (40 lb-in.)
Connecting Rod Cap Screws	20.9 N•m (185 lb-in.)
Counterweight Bolt	13 N•m (115 lb-in.)
Cylinder Head Cap Screws	24.8 N•m (220 lb-in.)
Cylinder Shield	6.2 N•m (55 lb-in.)
Drive Belt Idler Pulley	9.6 N•m (85 lb-in.)
Engine Mounting Bolts	32 N•m (24 lb-ft)
Engine Output Pulley Assembly	75 N•m (55 lb-ft)
Exhaust Manifold	18.5 N•m (165 lb-in.)
Flywheel Nut	136.0 N•m (100 lb-ft)
Flywheel Screen Screws	6.2 N•m (55 lb-in.)
Fuel Shutoff Solenoid	4.4 N•m (40 lb-in.)
Governor Arm Lock Nut	4.4 N•m (40 lb-in.)
Head Bolts (Final)	24.9 N•m (220 lb-in.)
Heat Shield Screws	4.4 N•m (40 lb-in.)
Ignition Armature	2.8 N•m (25 lb-in.)
Intake Manifold Elbow	11.3 N•m (100 lb-in.)
Oil Breather Mounting Bolt	6.2 N•m (55 lb-in.)
Oil Filter Adaptor Mounting Bolts	14.7 N•m (130 lb-in.)
Oil Pump Cover Mounting Screws	9.0 N•m (80 lb-in.)
Rocker Arm Adjustment Lock Nut	6.8 N•m (60 lb-in.)
Rocker Arm Studs	9.6 N•m (85 lb-in.)
Starting Motor Mounting Bolts	16 N•m (140 lb-in.)
Starting Motor Thru Bolts	5.7 N•m (50 lb-in.)
Stator to Cylinder Block	3.9 Nm (35 lb in.)
Spark Plug	20 N•m (180 lb-in.)
Sump Cover	15.8 N•m (140 lb-in.)
Throttle Valve Plate	4.4 N•m (40 lb-in.)
Valve Cover Nuts	6.8 N•m (60 lb-in.)