

# 317 Hydrostatic Tractor



JOHN DEERE

## TECHNICAL MANUAL

### 317 Hydrostatic Tractor

TM1208 (01OCT81) English

John Deere  
Lawn & Grounds Care Division  
TM1208 (01OCT81)

LITHO IN U.S.A.  
ENGLISH



## INTRODUCTION

This technical manual contains service and maintenance information for the John Deere 317 Hydrostatic Tractor.

The manual is divided into sections. Each section pertains to a certain component or operational system of the tractor. The information is divided into groups within each section.

All sections of this technical manual should be carefully studied by the service technician. Much basic information such as the principles of 4-cycle engine operation, carburetion and ignition have been omitted. Such information can be found in any good library and is recommended reading for the new service technician before consulting this manual for service procedures.

Emphasis is placed on diagnosing malfunctions, analysis and testing. Diagnosing malfunctions lists possible troubles, their causes and how to correct them. Under specific components these troubles are analyzed to help the service technician understand what is causing the problem so it can be corrected rather than just replace parts and have the same problem keep recurring.

Specifications are found at the end of each Section for easy reference.



**This safety alert symbol identifies important safety messages in this manual. When you see this symbol, be alert to the possibility of personal injury and carefully read the message that follows.**

Metric equivalents have been included, where applicable, throughout this technical manual.

Vertical lines appear in the margins of many of the pages. These lines identify new material and revised information that affects specifications, procedures, and other important instructions.

# JOHN DEERE 317 HYDROSTATIC TRACTOR

Technical Manual  
TM-1208 (Oct-81)

## TABLE OF CONTENTS

### SECTION 10 - GENERAL

- Group 5 - Tractor Identification
- Group 7 - Tractor and Engine Change Identification
- Group 10 - Specifications
- Group 15 - Fuel and Lubricants
- Group 20 - Tune-up and Adjustments

### SECTION 20 - ENGINE - SER. NO.

( -11,025,872)

- Group 5 - General Information
- Group 10 - Cylinder Heads, Valves and Breather
- Group 15 - Engine Removal and Installation
- Group 20 - Internal Components
- Group 25 - Specifications

### SECTION 22 - ENGINE - SER. NO.

(11,025,873- )

- Group 5 - General Information
- Group 10 - Cylinder Heads, Valves and Breather
- Group 15 - Engine Removal and Installation
- Group 20 - Internal Components
- Group 25 - Specifications

### SECTION 30 - FUEL SYSTEM

- Group 5 - General Information
- Group 10 - Carburetor - Engine Serial No. ( -11,053,429)
- Group 12 - Carburetor - Engine Serial No. (11,053,430- )
- Group 15 - Governor
- Group 20 - Fuel Tank
- Group 25 - Fuel Pump
- Group 30 - Air Cleaner - Engine Serial No. ( -11,025,872)
- Group 32 - Air Cleaner - Engine Serial No. (11,025,873-11,053,429)
- Group 34 - Air Cleaner - Engine Serial No. (11,053,430- )
- Group 35 - Specifications

### SECTION 40 - ELECTRICAL SYSTEM

- Group 5 - General Information
- Group 10 - Cranking System
- Group 15 - Ignition System
- Group 20 - Charging System
- Group 25 - Lights
- Group 30 - PTO Clutch

### SECTION 50 - POWER TRAIN

- Group 5 - General Information
- Group 10 - Brakes
- Group 15 - Hydrostatic Transmission
- Group 20 - Hydrostatic Control Linkage
- Group 25 - Differential and Axle

### SECTION 60 - HYDRAULIC SYSTEM

- Group 5 - General Information
- Group 10 - Hydraulic Circuit
- Group 15 - Hydraulic Control Valve
- Group 17 - Flow Diverter Valve
- Group 20 - Hydraulic Cylinder

### SECTION 70 - MISCELLANEOUS

- Group 5 - Steering Linkage
- Group 10 - Front Wheels and Axles

### SECTION 80 - SPECIAL SERVICE TOOLS

- Group 5 - Engine Essential Service Tools
- Group 10 - Engine Convenience Service Tools
- Group 15 - Tractor Convenience Service Tools

### SECTION 90 - TRACTOR ATTACHMENTS

- Group 5 - 49 Snow Thrower
- Group 10 - 41 and 48 Rotary Mowers
- Group 15 - 33 Rotary Tiller
- Group 20 - 542 PTO Attachment

*(All information, illustrations and specifications contained in this technical manual are based on the latest information available at the time of publication. The right is reserved to make changes at any time without notice).*

OOA

Copyright © 1981 Deere & Company  
Previous Editions  
Copyright © 1980 Deere & Company  
Copyright © 1978 Deere & Company

# Section 10 GENERAL

## TABLE OF CONTENTS

	Page		Page
<b>GROUP 05 - TRACTOR IDENTIFICATION</b>		<b>GROUP 15 - FUELS AND LUBRICANTS</b>	
Tractor Serial Number .....	5-01	Fuel .....	15-01
Engine Serial Number .....	5-01	Choose Proper Engine Oil .....	15-02
Transmission Serial Number .....	5-01	Choose Proper Hydraulic Oil .....	15-02
<b>GROUP 07 - TRACTOR AND ENGINE CHANGE IDENTIFICATION</b>		Choose Proper Grease .....	15-03
General .....	7-01	Capacities .....	15-03
Tractor Serial No. ( -156,000) .....	7-01	Service Intervals .....	15-04
Tractor Serial No. (156,001-160,062) .....	7-04	Check Transmission Fluid Level .....	15-04
Tractor Serial No. (160,063- ) .....	7-05	Change Transmission Fluid and Filter .....	15-05
<b>GROUP 10 - SPECIFICATIONS</b>		Check Engine Oil Level .....	15-05
Tractor Specifications .....	10-01	Change Engine Oil .....	15-06
Bolt Torque Chart .....	10-02	Lubricate Linkage .....	15-07
Set Screw Seating Torque Chart .....	10-02	<b>GROUP 20 - TUNE-UP AND ADJUSTMENTS</b>	
		General .....	20-01
		Engine Tune-up .....	20-01
		Tractor Adjustment .....	20-02

**Group 05**  
**TRACTOR IDENTIFICATION**

**TRACTOR SERIAL NUMBER**

The tractor serial number plate (A) is located on the pedestal just above the key switch.

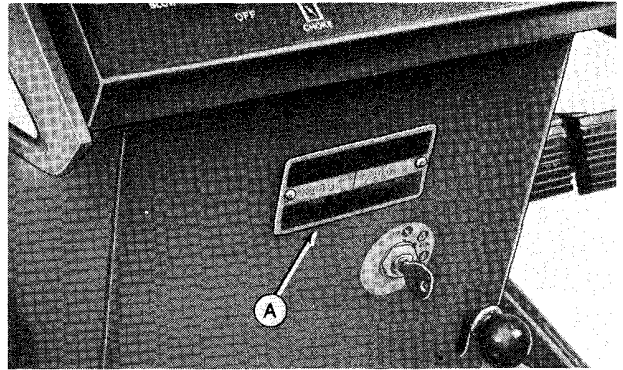

M29353/1208/1005B/080781

**ENGINE SERIAL NUMBER**

The engine serial number plate (A) is located on top of the blower housing.

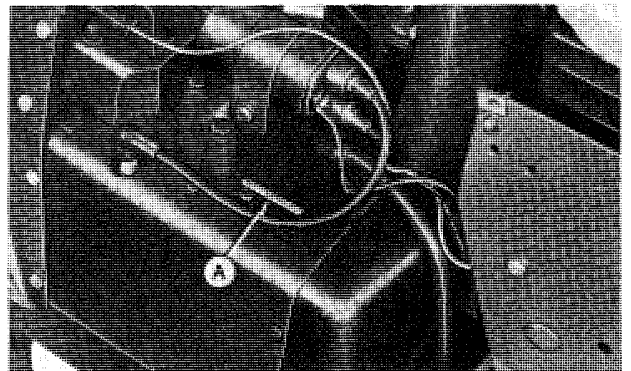

M29354/1208/1005C/080781

**TRANSMISSION SERIAL NUMBER**

The transmission serial number (A) is located above the oil filter on the front of the transmission.



M29355/1208/1005D/080781

## Group 07 CHANGE IDENTIFICATION

### GENERAL

The material in this group will aid in identifying the machine by serial number. This information will assist in using the proper Section or Group when performing service on the machine. Tractor Serial Numbers ( -156,000) are identified by Engine Serial Number.

1208/1007A/080781

**TRACTOR SERIAL NO. ( -156,000)**  
**ENGINE SERIAL NO. ( -10,135,763)**

1. Engines in this Serial No. range can be identified by use of an air intake hose (A) on air canister (B).

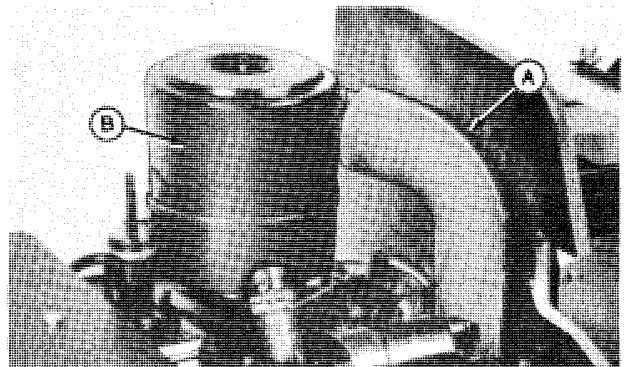

M2902B/1208/1007B/080781

2. Engines in this serial no. range used a flywheel screen (A).

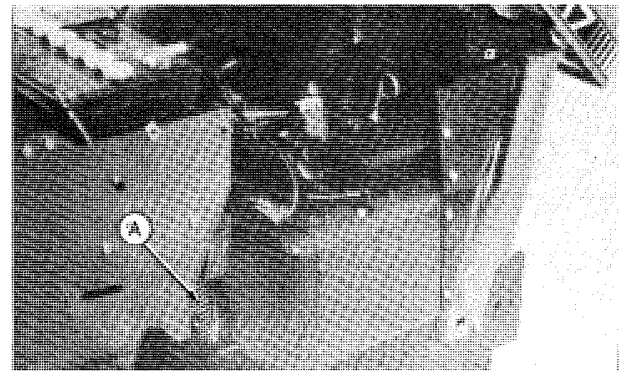

M29029/1208/1007C/080781

3. Some engines in this Serial No. range may have been modified to include a carburetor adapter (A) mounted on elbow (B).

*NOTE: Some adapters are a permanent part of elbow (B) while other adapters are loose with a gasket between adapter (A) and elbow (B).*

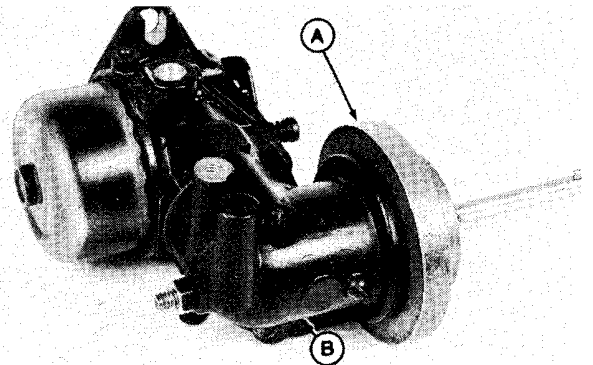

M28831/1208/1007D/080781

Change Identification

4. Some engines in this Serial No. range may have been modified to include a flywheel scraper (A).

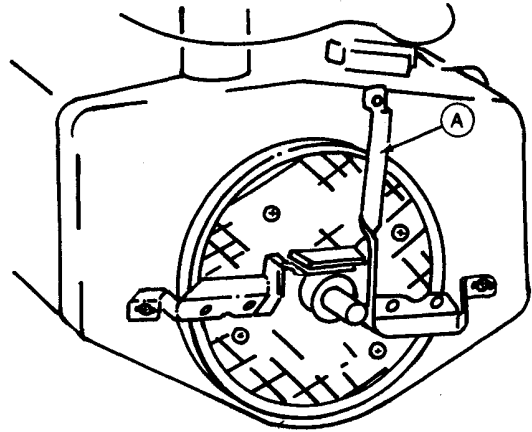

M29030/1208/1007E/080781

5. Because the flywheel screen and scraper are no longer available, some engines in this Serial No. range may have had the flywheel screen, flywheel scraper and air intake hose removed. In this case the engine can be identified by the use of engine shroud cover (A) where the air intake hose went into the engine shroud. The tractor then uses bottom screen (B) to replace the flywheel screen.

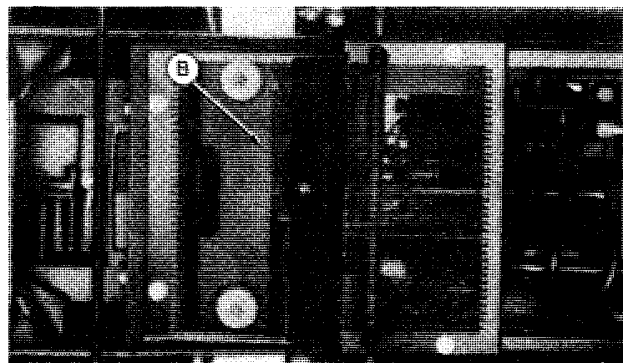
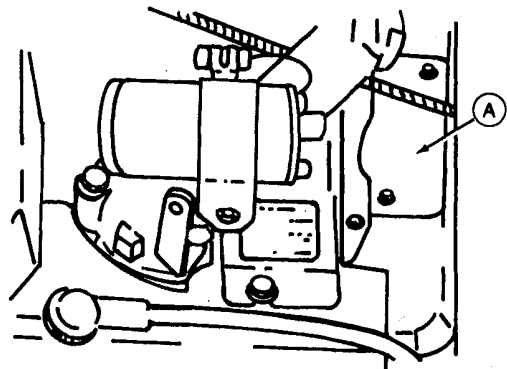

M29031/M29032/1208/1007F/080781

Change Identification

**TRACTOR SERIAL NO. (            -156,000)**  
**ENGINE SERIAL NO. (10,135,763-11,052,801)**

1. Engines in this Serial No. range are replacement engines. They use bottom screen (B).

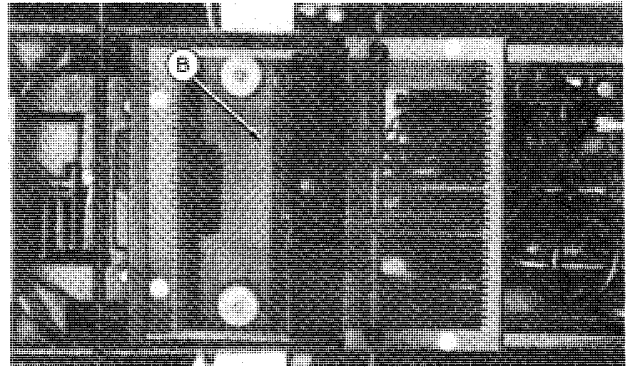

M29032/1208/1007G/080781

2. Engines in this Serial No. range used carburetor adapter (A) permanently fixed to elbow (B).

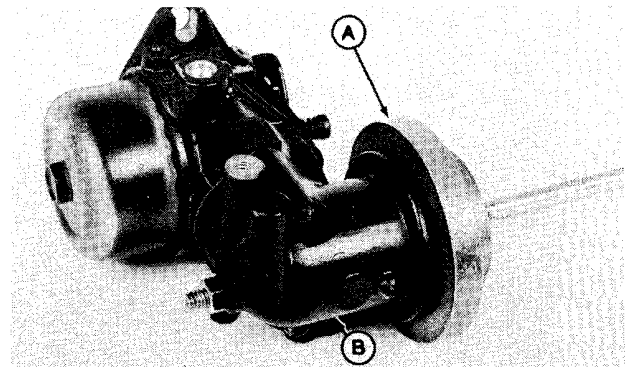

M28831/1208/1007H/080781

3. Engines in this Serial No. range can be further identified by the lack of a hole in the engine shroud where the air intake hose used to go.

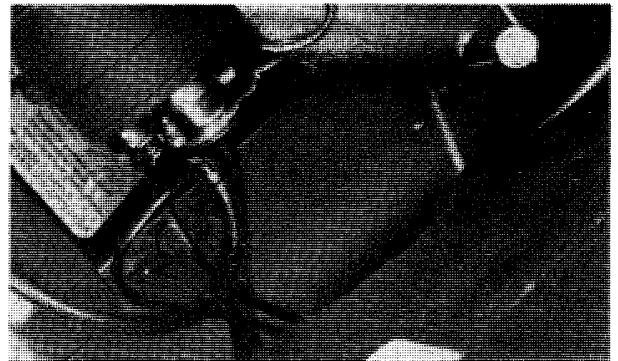

M29033/1208/1007I/080781

**TRACTOR SERIAL NO. (            -156,000)**  
**ENGINE SERIAL NO. (11,052,802-            )**

1. These engines can be identified by the use of O-ring (A) in carburetor elbow. This elbow is a one piece adapter and elbow.

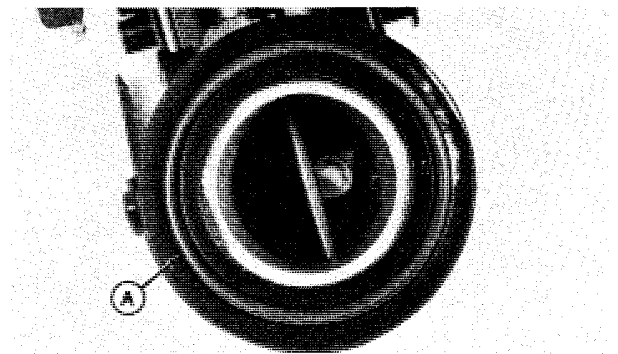

M28845/1208/1007J/080781



Change Identification

2. The air cleaner assembly (B) uses wing nut (A) washer (C) and sealing washer (D).

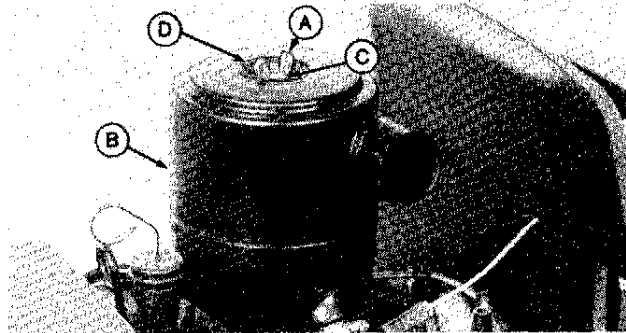

M28749/1208/1007K/080781

3. The tractor is equipped with bottom screen (B).

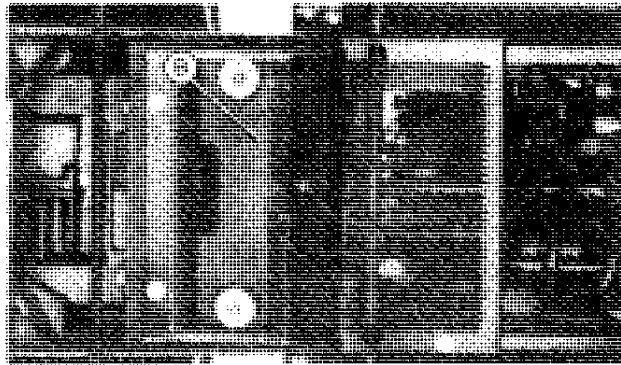

M28831/1208/1007N/080781

**TRACTOR SERIAL NO. (156,001-160,062)**

1. Tractors in this Serial No. range use bottom screen (B).

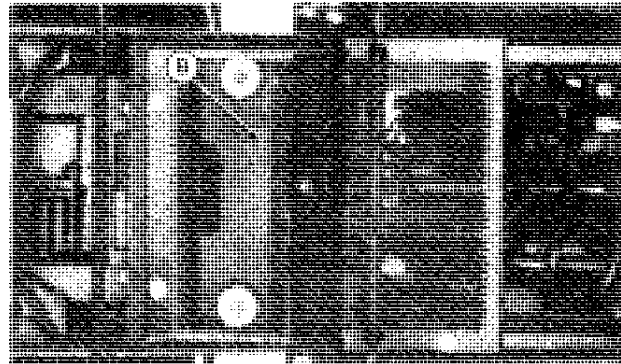

M28831/1208/1007N/080781

2. The carburetors used adapter (A) permanently fixed to elbow (B).

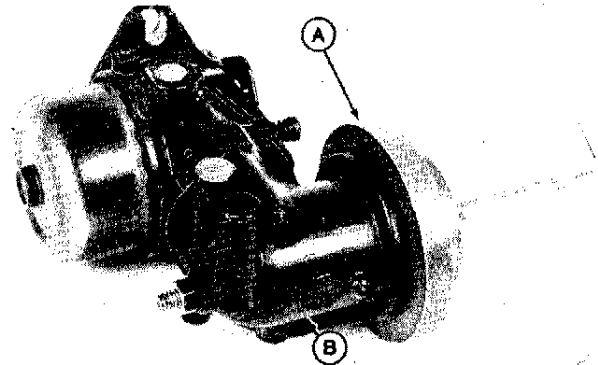

M28831/1208/1007N/080781

Change Identification

3. The engine shroud does not have a hole in it where the air intake hose used to go.



M29033/1208/1007O/080781

**TRACTOR SERIAL NO. (160,063- )**

1. Tractors in this Serial No. range use O-ring (A) in carburetor elbow. The elbow is a one piece adapter and elbow.

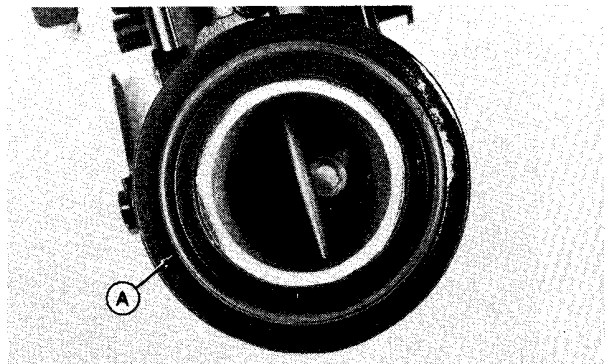

M28845/1208/1007P/080781

2. Air cleaner assembly (B) uses wing nut (A), washer (C) and sealing washer (D).

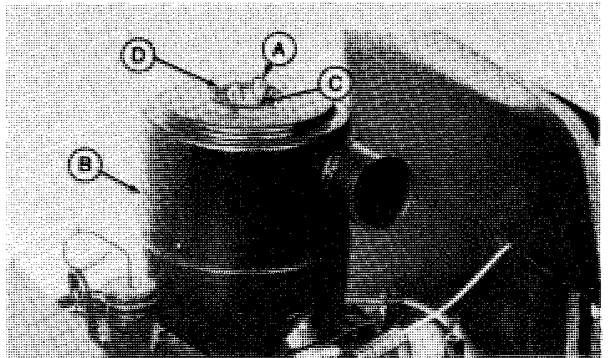

M28749/1208/1007O/080781

3. The tractor is equipped with bottom screen (B).

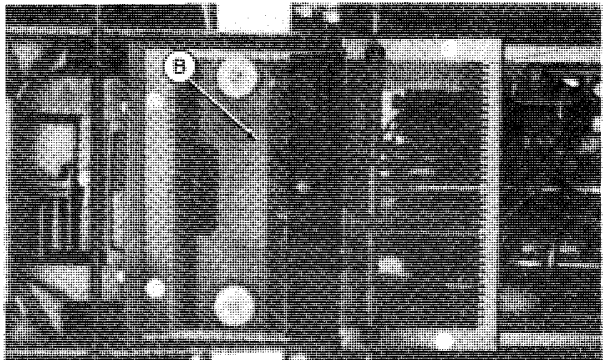

M29032/1208/1007R/080781

**TRACTOR SPECIFICATIONS**

**Engine**

Engine Model Number . . . . . KT17QS  
 Manufacturer . . . . . Kohler  
 Cylinder . . . . . Two  
 Cycle . . . . . Four  
 Bore . . . . . 3-1/8 in. (7.9 cm)  
 Stroke . . . . . 2-3/4 in. (7.0 cm)  
 Displacement . . . . . 42.18 cu. in. (691.4 cc)  
 Horsepower\* . . . . . 17 (12.58 kW)  
**Speeds**  
 Idle . . . . . 1200 rpm  
 High (No load) . . . . . 3400 to 3600 rpm

*\*Horsepower rating is established by engine manufacturer in accordance with Standard International Combustion Institute procedure. It is corrected to 60°F and 29.92 hg barometer. Laboratory test engines are equipped with air cleaner and muffler.*

**Electrical System**

Battery, John Deere  
 (AM31186) . . . . . Category II, 12-Volt BCI  
 Group 22F, 260 cold cranking amps  
 at 0°F (17.7°C), 50 minute reserve  
 capacity at 25 amps  
 Charging Capacity . . . . . 15 amps  
 System Polarity . . . . . Negative Ground  
 Starter . . . . . 12-Volt Motor, Key and Solenoid  
 Ignition . . . . . Battery-Coil  
 Spark Plug\*\* . . . . . Champion RBL15Y  
 or equivalent  
 Spark Plug Gap . . . . . .0.025 in. (0.64 mm)  
 Breaker Point Gap . . . . . .0.020 in. (0.508 mm)  
 Timing . . . . . Index

**Power Train**

Hydrostatic Transmission  
 Sundstrand 15 Series . . . . . (U-Type)  
 Differential . . . . . Dana  
 Brakes . . . . . Individual Rear Wheel (Drum-Type)

*\*\*In Canada, compliance with radio interference regulations certified. Replace spark plug with resistor type spark plug only.*

**Travel Speeds**

Forward . . . . . Variable 0.5 to 6.5 mph  
 (0.8 km/h to 10.5 km/h)  
 Reverse . . . . . Variable 0.5 to 3.5 mph  
 (0.8 km/h to 5.6 km/h)

**Hydraulics**

Control Valve . . . . . 2-Spool (open-center)  
 Outlets . . . . . 2 Sets (front)  
 Rockshaft . . . . . Mid-mounted

**Tire Size**

Front . . . . . 16 x 6.50-8 High-Flotation  
 Rear . . . . . 23 x 10.50-12 High-Flotation

**Tire Inflation\***

Front . . . . . 6 to 16 psi (41 to 110 kPa)  
 Rear . . . . . 5 to 10 psi (34 to 69 kPa)

**Wheel Tread (Center of Tires)**

Front . . . . . 31-1/4 in. (803.75 mm)  
 Rear (wheels in) . . . . . 30-1/2 in. (774.70 mm)  
 Rear (wheels out) . . . . . 33 in. (1 838.20 mm)

**Dimensions**

Wheelbase . . . . . 46 in. (1.168 m)  
 Over-all Length . . . . . 69 in. (1.753 m)  
 Over-all Height . . . . . 44 in. (1.118 m)  
 Over-all Width (Max.) . . . . . 42 in. (1.079 m)

Approximate Curb Weight . . . . . 760 lbs. (344.5 kg)

*\*Inflation will vary with attachment used.*

## SERVICE INTERVALS

### Crankcase (Oil Change)

Break-in . . . . . After first 5 hours

Regular . . . . . Every 25 hours

Dusty Conditions . . . . . Every 8 hours

### Transmission

Oil Change . . . . . 500 hours or 2 years

Oil Filter Change . . . . . 100 hours

*NOTE: Oil filter is positioned under transmission. Fill new filter with oil prior to installing it to prevent an air lock in the system.*

Tractor Grease Fittings . . . . . Every 25 hours

120B/1015F/090781

## CHECK TRANSMISSION FLUID LEVEL

*NOTE: DO NOT run tractor engine when checking or adding fluid.*

Fluid level in sight tube (B) should be 1/4 to 1-1/4-inches (5 to 30 mm) above bottom of slot in frame when tractor engine is stopped.

**IMPORTANT:** The 1/16-inch diameter hole in outside wall of accumulator-vent (C) must be positioned at an upward angle to prevent fluid leakage and insure proper venting.

If fluid level is low, remove fill tube cap (A) and add necessary amount of fluid until it is 1/4 to 1-1/4 inches (5 to 30 mm) above bottom of slot in frame.

**IMPORTANT:** Do not overfill.

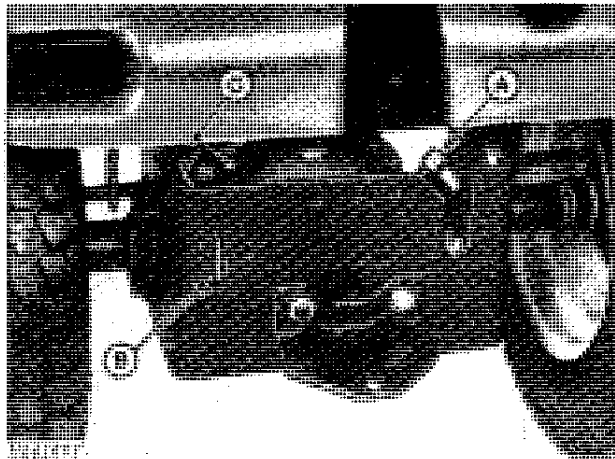

M2c166/1208/1015C/090781

## FUEL



**CAUTION:** Do not fill gas tank when engine is running or hot. Do not smoke when filling gas tank.

Wipe dust and dirt from around filler cap (A) before removing it. Place cap in a clean area.

**IMPORTANT:** Do not permit dirt or other foreign matter to enter the fuel system. This may cause hard starting, poor performance and engine damage. Always use clean gasoline storage cans and funnels.

Fill the gas tank with fresh, clean "regular" grade gasoline. We recommend non-leaded gasoline because it reduces cylinder head deposits. Low-lead or leaded "regular" grades are acceptable.

DO NOT use premium, ethyl or white gasoline.

The use of gasohol is not recommended.

Never use special additives such as carburetor cleaners, de-icers, or moisture-removing liquids in your gasoline.

**IMPORTANT:** Do not mix oil with gasoline.



M29356/1015A/090781

**TORQUE CHARTS**

**Bolt Torque Chart**

**AVERAGE TIGHTENING TORQUE FOR BOLTS  
(BASED ON 85% OF YIELD)**

BOLT SIZE	A17B			A17D			A17F		
	lb-in	lb-ft	Nm	lb-in	lb-ft	Nm	lb-in	lb-ft	Nm
1/4	72	6	8	120	10	13.5	168	14	19
5/16	156	13	17.6	240	20	27	360	30	40.7
3/8	276	23	31.2	420	35	47.5	600	50	67.8
7/16	420	35	47.5	660	55	74.6	960	80	108.5
1/2	660	55	74.6	1020	85	115.2	1440	120	162.7
9/16	900	75	101.7	1560	130	176.3	2100	175	237.3
5/8	1260	105	142.4	2040	170	230.5	2880	240	325.4
3/4	2220	185	250.8	3600	300	406.7	5100	425	576.2
7/8	1920	160	216.9	5340	445	603.3	8220	685	928.7
1	3000	250	339	8040	670	908.4	12360	1030	1396.5
1-1/8	3960	330	447.4	10920	910	1233.8	17520	1460	1979.5
1-1/4	5760	480	650.8	15000	1250	1694.8	24720	2060	2793

B grade bolts larger than 3/4 are sometimes formed hot rather than cold, which accounts for the lower mean tightening torque.

**Set Screw Seating Torque Charts**

Screw Size	Seating Torque	
	Inch-Pounds	Newton Meters (Nm)
#5	9	1.0
#6	9	1.0
#8	20	2.3
#10	33	3.7
1/4	87	9.8
5/16	165	18.6
3/8	290	32.8
7/16	430	48.6
1/2	620	70.1
9/16	620	70.1
5/8	1225	138.4
3/4	2125	240.1

1208/10-10B/080781

**CHOOSE PROPER GREASE**

John Deere Multipurpose Grease is recommended in all grease fittings. If other greases are used, use SAE Multipurpose Grease containing 3 to 5 percent molybdenum disulfide.

Use grease as shown in temperature chart.

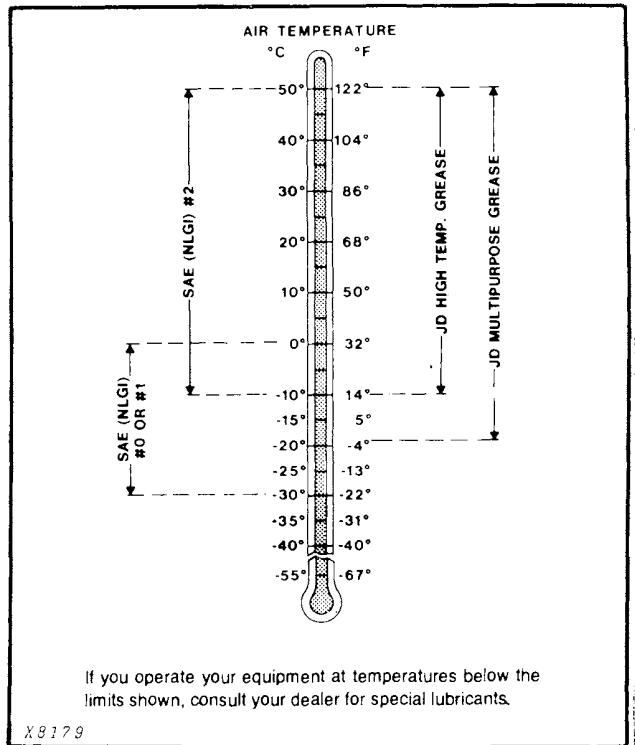

X8179/1208/1015D/090781

**CAPACITIES**

Fuel Tank . . . . . 4-1/2 U.S. gal. (17.034 L)

Crankcase . . . . . 3-1/2 U.S. pt. (1.65 L)

Transmission . . . . . 5 U.S. qt. (4.731 L)

1208/1015E/090781

### CHOOSE PROPER ENGINE OIL

This machine has been filled at the factory with break-in oil that can be used only between 32°F (0°C) and 75°F (24°C).

For first 5 hours of operation, use only the oils listed below:

- Below 32°F (0°C) — Drain break-in oil before using. Fill with SAE 5W-20.
- 32°F (0°C) to 75°F (24°C) — Use break-in oil.
- Above 75°F (24°C) — Drain break-in oil before using. Fill with SAE 30.

After the first 5 hours of break-in operation, drain the engine crankcase and refill with fresh oil.

Use John Deere TORQ-GARD SUPREME® engine oil for use in the engine crankcase. TORQ-GARD SUPREME oil was formulated to provide all the protection your engine needs, so never put additives in the crankcase.

If oil other than TORQ-GARD SUPREME is used, it must conform to one of the following specifications:

API Service Classification CC-SC-SD-SE-SF

Depending upon the expected prevailing temperature for the fill period, use oil of viscosity as shown.

Some increase in oil consumption may be expected when SAE 5W-20 is used. Check oil level frequently.

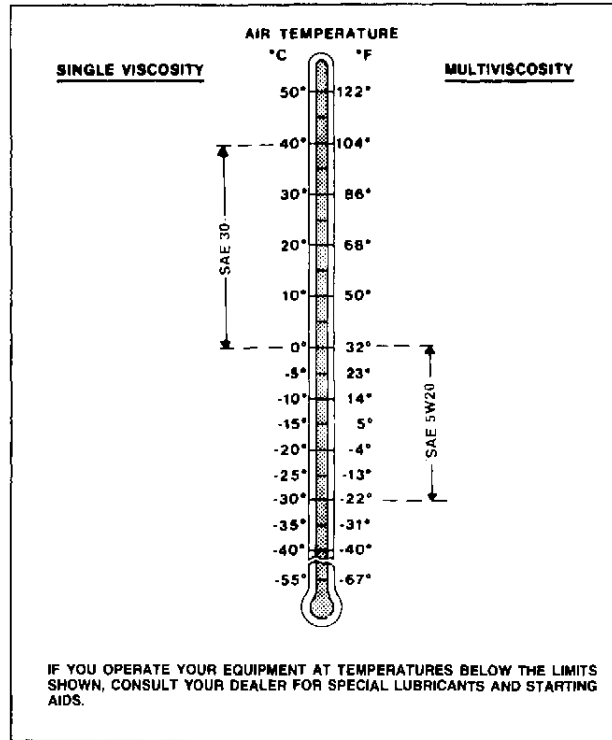

M27560/1208/1015B/090781

### CHOOSE PROPER HYDRAULIC OIL

Use John Deere All-Weather Hydrostatic Fluid, John Deere HY-GARD® Transmission and Hydraulic Oil, or an equivalent Type "F" Automotive Automatic Transmission Fluid.

1208/1015C/090781



## CHANGE TRANSMISSION FLUID AND FILTER

**IMPORTANT:** Be extremely careful to prevent dirt from entering hydraulic system. Clean dust and dirt from edges of filter (B) from around fill tube cap, and transmission-to-axle cooling tube (A) before removing them.

1. Remove transmission-to-axle cooling tube (A).
2. Allow all fluid to drain into a container.
3. Reinstall transmission-to-axle cooling tube (A).
4. Remove filter (B). Fill a new filter half-full of transmission fluid. Moisten rubber filter gasket with fluid. Install filter finger-tight only.
5. Fill transmission with John Deere All-Weather Hydrostatic Fluid, John Deere HY-GARD® Transmission and Hydraulic Oil, or an equivalent Type "F" Automotive Automatic Transmission Fluid.
6. Transmission capacity is 5 U.S. quarts (4.731 L). Pour in only 3 quarts (2.839 L). Check transmission fluid level as explained earlier before adding more fluid. Fill transmission to proper level.

**IMPORTANT:** After changing fluid and filter and before operating hydrostatic control lever, start engine and move inner hydraulic control lever and move inner hydraulic control lever back and forth several times. Observe that lift system is operating before moving hydrostatic control lever. This insures that the entire system is filled. Do not overfill.

Stop engine and recheck fluid level. Add fluid if necessary to bring level up to midpoint of slot in frame.

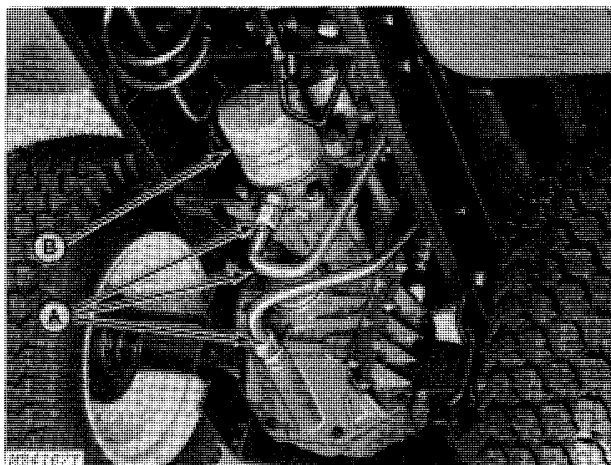

M24167/1208/1015H/090781

## CHECK ENGINE OIL LEVEL

1. Park tractor on a level surface.
2. Stop engine and raise hood.
3. Wipe dust and dirt from around dipstick (A).
4. Remove dipstick and wipe it off with a clean rag. Reinsert dipstick and push it down tight. Remove dipstick and check that oil level is up to "F" mark. If oil level is low, remove fill tube cap (B) and add necessary amount of oil to bring level up to "F" mark on dipstick.

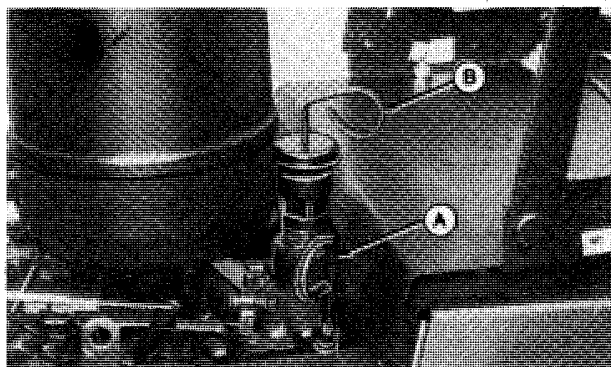

M28257/1208/1015H/090781

## CHANGE ENGINE OIL

**IMPORTANT:** Always drain crankcase oil when it is hot and all dirt and foreign material is in suspension.

1. Turn oil drain valve (A) counterclockwise to open. Drain oil into a container.

**IMPORTANT:** Use a pliers to loosen or open valve. When closing valve after oil has drained, **DO NOT** use a pliers to tighten. Hand-tighten only. Otherwise, valve may be damaged.

2. Close valve (A) (clockwise) after oil has completely drained.

**NOTE:** For convenience, a suitable length of 5/8-inch (15.88 mm) garden hose or plastic tubing can be installed over drain valve spout to allow oil to drain away from tractor.

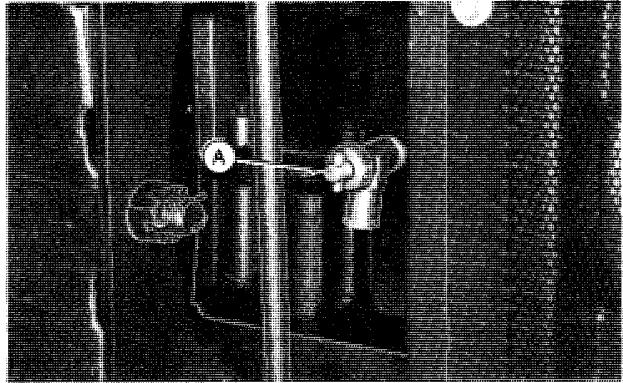

M28767/1208/1015J/090781

3. Remove fill tube cap (B) and add approximately 3 pints (1.42 L) oil of the proper viscosity. See chart for recommended oil. Remove dipstick (A) and wipe it off with a clean rag. Reinsert dipstick and push it down tight. Remove dipstick and check to be sure oil level is up to the "F" mark on dipstick. The oil level should never be over the "F" mark on dipstick. Overfilling can cause engine overheating resulting in loss of power and permanent engine damage. Add only the necessary amount of oil to bring level up to "F" mark on dipstick when it is installed and pushed down tight.

4. Reinstall fill tube cap (B) and dipstick (A) after oil is added to crankcase and checked.

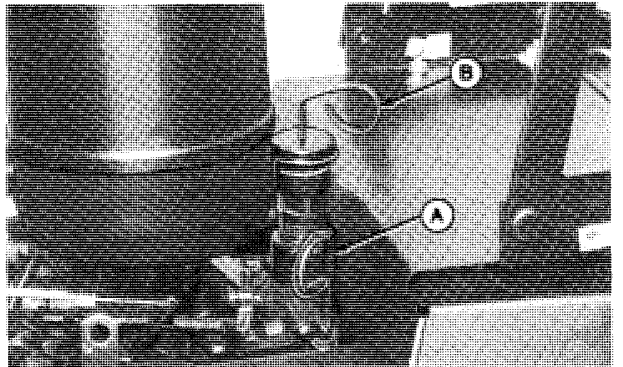

M28257/1208/1015K/090781

### LUBRICATE LINKAGE

Lubricate fittings using a hand grease gun. Wiper fittings clean before and after lubrication.

Excessive steering wheel play or difficult movement of the front axle may be the result of mis-adjustment. If this occurs, adjust axle pivot plates and bolt as explained in Section 70.

Grease fittings are located as follows:

Ref.	Qty.	Location
(A)	2	Front Wheel Hubs
(B)	2	Front Axle Spindles
(C)	2	Brake Pedal Shaft

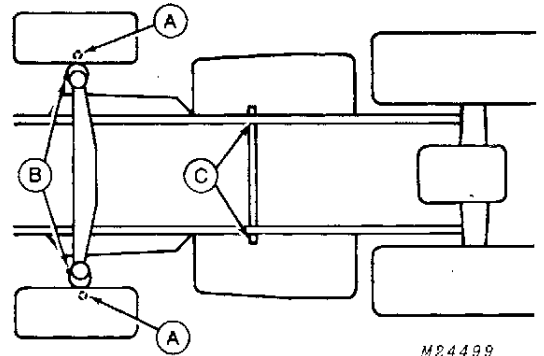

## **GENERAL**

This group is intended to provide a service procedure for tractors that are running well. Minor repairs and adjustments made in an orderly fashion will improve the efficiency and operation of the tractor.

1208/1020A/090781

## **ENGINE TUNE-UP**

Engine tune-up involves checking, servicing and adjusting engine components - including the ignition system, air intake system, fuel and lubrication systems.

\*Perform engine tune-up in the following order:

1. Clean engine and cooling system.
2. Service air cleaner.
3. Check compression.
4. Check and adjust breaker points.
5. Check spark plugs.
6. Check and adjust timing.
7. Test crankcase vacuum.
8. Clean crankcase breather.
9. Adjust carburetor.
10. Clean and service battery.
11. Change crankcase oil.
12. Clean bottom screen (if equipped)
13. Reinstall hood, grille and side panels.

*\*Engine tune-up procedures are shown starting on page 10-20-2.*

1208/1020B/090781

## TRACTOR ADJUSTMENT

Tractor adjustments are made to assure that engine horsepower will be utilized in the most efficient manner. A thorough visual inspection of the complete tractor, as you make the adjustments, will help in determining any extra service required on the tractor.

\*Perform tractor adjustment in the following order:

1. Check transmission fluid.
2. Lubricate linkage.
3. Check brake adjustment.
4. Adjust hydrostatic linkage.
5. Check hydrostatic control lever brake adjustment.
6. Check hydraulic system charge pressure.
7. Check implement relief valve pressure.
8. Adjust steering gear.
9. Adjust steering backlash.
10. Adjust front wheel toe-in.
11. Adjust front axle pivot.
12. Adjust turning radius.
13. Clean fuel strainer.
14. Check wiring.
15. Check belts and equipment.
16. Check tire pressure.

\*Tractor adjustment procedures are shown starting on page 10-20-16.

1208/1020C/090781

## CLEAN ENGINE AND COOLING SYSTEM

1. Remove grill by placing hand under emblem (A) and pulling outward.

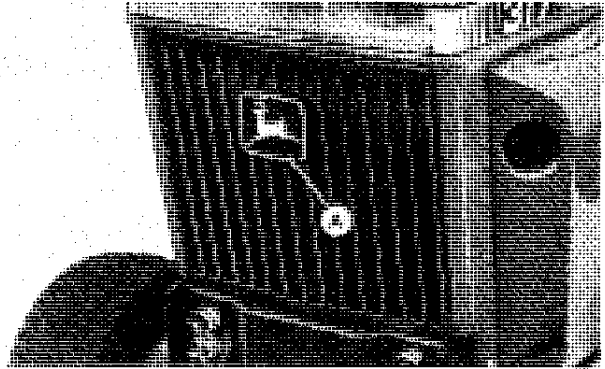

M28/46/1208/1020D/090781

2. Raise hood (A).
3. Remove three cap screws (B) and side panel (C) from both sides of tractor.

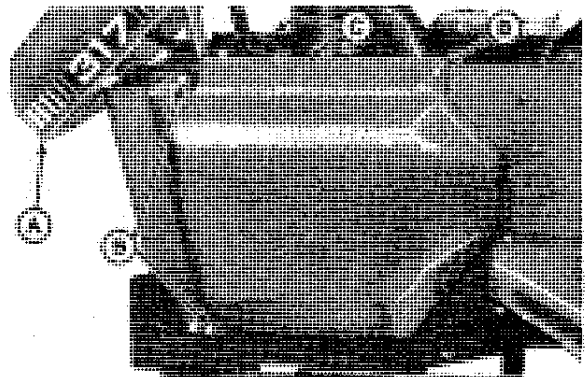

M24168/1208/1020F/100781

## Tune-Up and Adjustments

4. Disconnect headlight wiring coupler (C).

*NOTE: On some model 317 Tractors, the wiring harness is clipped to the air cleaner. On these tractors, disconnect wiring harness from air cleaner.*

5. Remove four spinlock screws (A—two each side).
6. Remove hood and cowl assembly (B).

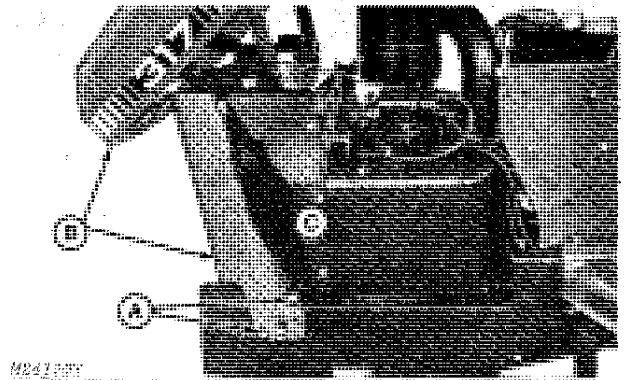

M24170F

M24170/120B/1020F/1007B1

7. Clean engine with compressed air before removing front shroud and loosening side shrouds. After cleaning engine, remove cap screws (A). Remove spark plugs (E). Plug spark plug holes with rags.

8. Remove front shroud (B) and spring side shrouds (C) slightly outward for access to engine cooling fins.

*NOTE: Some Model 317 Tractors are equipped with two-piece side shrouds. On these tractors, remove the top part of shroud only for access to cooling fins.*

9. Blow grass and foreign material off shrouds and engine cooling fins. Clean air intake screen (D) on rear of engine. Reinstall shrouds (B and C) after engine is cleaned.

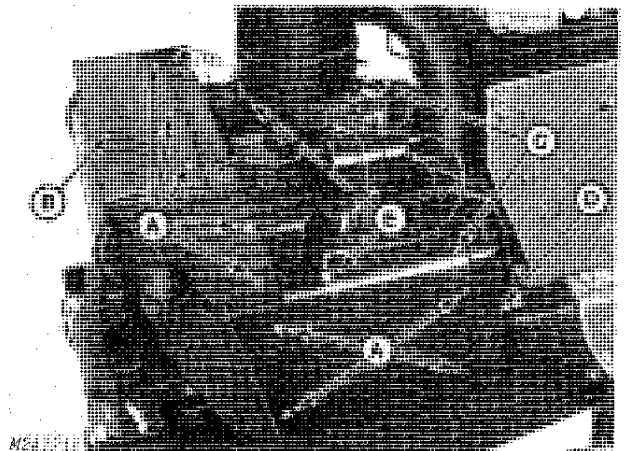

M24171F

*NOTE: On engine Serial No. (10,135,763- ) air intake screen (D) is not used.*

A—Cap Screws  
B—Front Shroud

C—Side Shrouds  
D—Air Intake Screen  
E—Spark Plugs

M24171/120B/1020G/1007B1

**Thank you very much for your reading. Please Click Here. Then Get COMPLETE MANUAL. NO WAITING**



**NOTE:**

**If there is no response to click on the link above, please download the PDF document first and then click on it.**

**SERVICE AIR CLEANER - ENGINE SERIAL NO. ( -10,135,763)**

*NOTE: On some model 317 Tractors, disconnect wiring harness from air cleaner.*

1. Remove wing nut (A).
2. Slip intake hose (B) off canister and remove from air intake shroud (D).

*NOTE: On some tractors, intake hose (B) may have been removed and a cover plate put in air intake shroud (D) where hose went in.*

3. Remove air cleaner assembly (C).

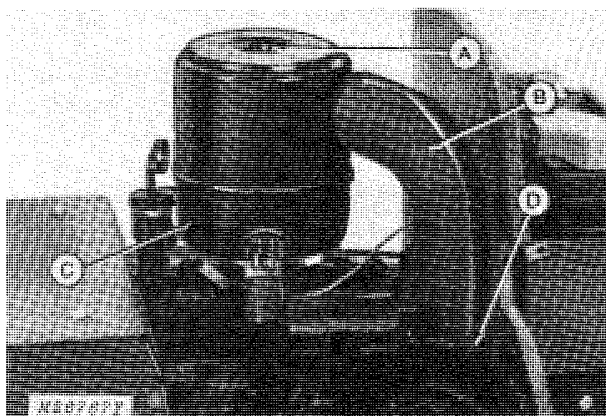

M26767/1208/1020H/100781

4. Pull cover (B) and base (D) apart. Remove element (C).
5. Tape element (C) lightly against a flat surface to shake out dust. Use a soft brush to remove foreign particles.

**IMPORTANT: Never use a liquid cleaner or compressed air to clean element (C). Replace element if damaged or extremely dirty.**

6. Wipe dust and dirt from cover (B) and base (D). Inspect gasket (E), dump valve (F) and intake hose (G) for cracks or deterioration. Replace parts as necessary.

**IMPORTANT: When replacing air cleaner assembly, be sure dump valve (F) is positioned so it does not touch intake manifold. Otherwise, it may become burned and damaged. If equipped, be sure intake hose (G) is secured tightly to cover (B) and air intake shroud (D) or damage to engine may occur from excessive dust and dirt entering and plugging air cleaner.**

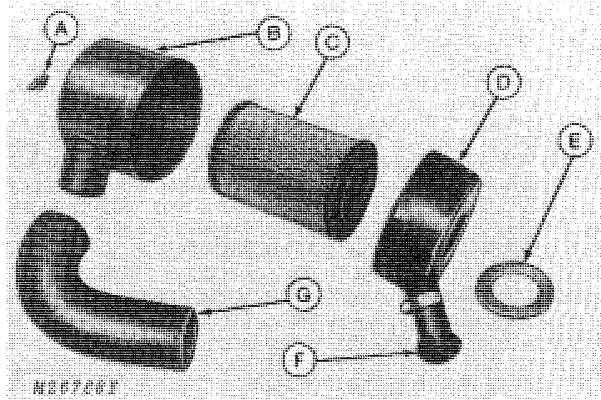

A—Wing Nut  
B—Cover  
C—Element  
D—Base

E—Gasket  
F—Dump Valve  
G—Intake Hose

M26768/1208/1020I/100781



**SERVICE AIR CLEANER - ENGINE SERIAL NO. (10,135,764-11,052,801)**

1. Remove wing nut (A).
2. Remove air cleaner assembly (B) and gasket under air cleaner base.

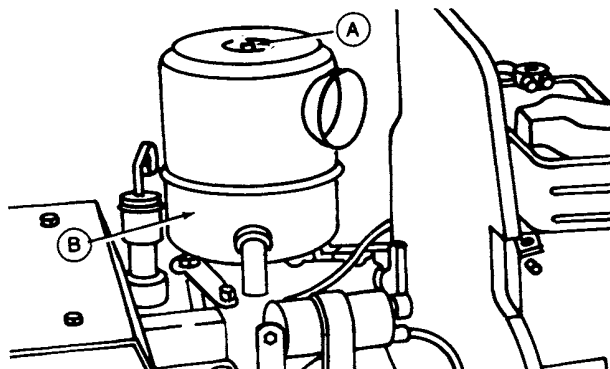

M28852/1208/1020J/100781

3. Pull cover (B) and base (D) apart. Remove element (C).
4. Tap element (C) lightly against a flat surface to shake out dust. Use a soft brush to remove foreign particles.

**IMPORTANT: Never use a liquid cleaner or compressed air to clean element (C). Replace element if damaged or extremely dirty.**

5. Wipe dust and dirt from cover (B) and base (D). Inspect gasket (E), and dump valve (F) for cracks or deterioration. Replace parts as necessary.

**IMPORTANT: When replacing air cleaner assembly, be sure dump valve (F) is positioned so it does not touch intake manifold. Otherwise, it may become burned and damaged.**

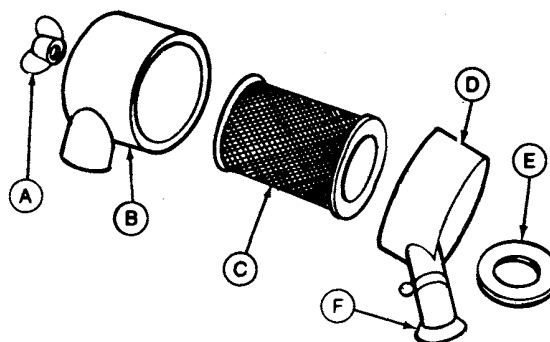

A—Wing Nut  
B—Cover  
C—Element  
D—Base  
E—Gasket  
F—Dump Valve

M28853/1208/1020K/100781

**SERVICE AIR CLEANER - ENGINE SERIAL NO. (11,052,802- )**

1. Remove wing nut (A), washer (C) and sealing washer (D).
2. Remove air cleaner assembly (B).

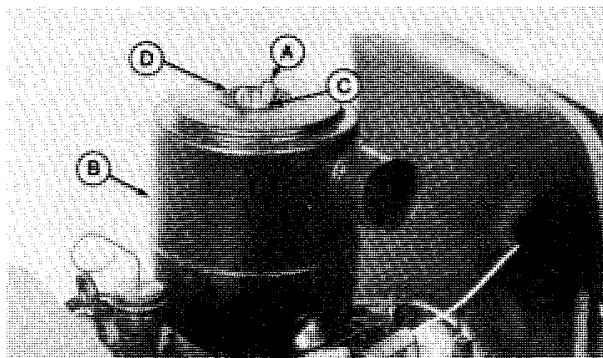

M28749/1208/1020L/100781

## Tune-Up and Adjustments

3. On later model tractors, remove cap screw (A) from clamp (B) then remove air cleaner.

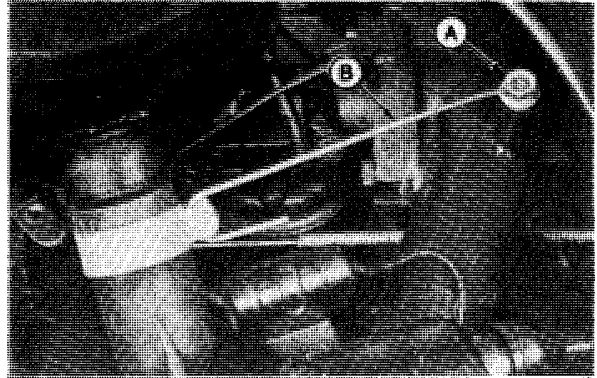

M28750/1208/1020M/100781

4. Pull cover (D) and base (F) apart. Remove element (E).  
5. Tap element (E) lightly against a flat surface to shake out dust. Use a soft brush to remove foreign material. Wipe dust from cover (D) and base (F).

**IMPORTANT:** Never use a liquid cleaner or compressed air to clean element (E). Replace element if damaged or extremely dirty.

6. Check dump valve (G) and sealing washer (C) for cracks or deterioration. Replace parts as needed.

7. Check carburetor elbow O-ring. See Section 30, Group 12. Replace if cracked or deteriorated.

**IMPORTANT:** Position dump valve (G) on air cleaner base, so it does not touch the intake manifold or governor linkage. Securely tighten wing nut (A) to prevent air cleaner from turning.

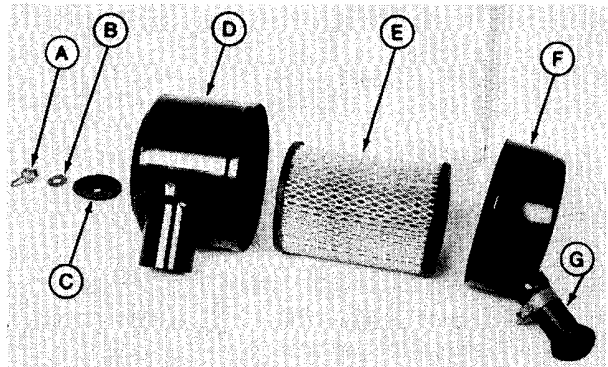

A—Wing Nut  
B—Washer  
C—Sealing Washer  
D—Cover

E—Element  
F—Base  
G—Dump Valve

M28655/1208/1020N/100781

8. On some tractors, hook clamp (B) in dump valve clamp. Install cap screw (A).

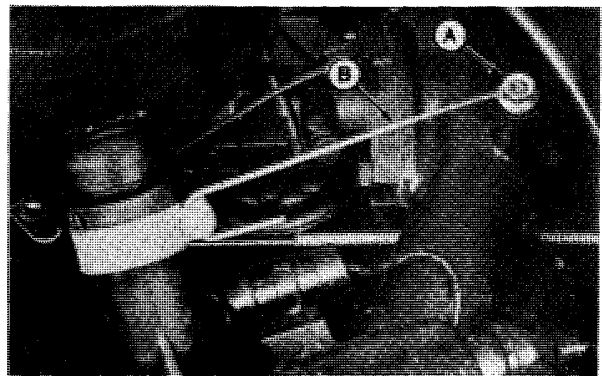

M28750/1208/1020O/100781