

# John Deere 1020, 1120 and 1630 Tractors



JOHN DEERE

## TECHNICAL MANUAL John Deere 1020, 1120 and 1630 Tractors

TM4286 (01AUG73) English

**TM4286 (01AUG73)**

LITHO IN U.S.A. (NEW)  
ENGLISH

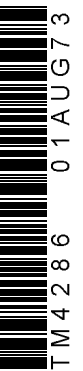

# 1020, 1120 and 1630 Tractors

(1020 and 1120 Tractors from Serial No. 115000L)

Technical Manual  
TM-4286 (Aug-73)

## CONTENTS

### SECTION 10 — GENERAL

- Group 5 - Specifications
- Group 10 - Pre-delivery, delivery and after-sales inspections
- Group 15 - Lubrication and periodic service
- Group 20 - Engine and tractor tune-up
- Group 25 - Tractor separation

### SECTION 20 — ENGINE

- Group 5 - General information, diagnosing malfunctions
- Group 10 - Cylinder head and camshaft
- Group 15 - Cylinder block, liners, pistons and connecting rods
- Group 20 - Crankshaft, main bearings and flywheel
- Group 25 - Timing gear train
- Group 30 - Oil pump, oil pressure regulating valve, oil cooler and oil filter
- Group 35 - Engine cooling system
- Group 40 - Speed control linkage

### SECTION 30 — FUEL SYSTEM

- Group 5 - Diagnosing malfunctions
- Group 10 - Fuel tank, water trap, transfer pump and fuel filter
- Group 15 - ROTO DIESEL fuel injection pump
- Group 20 - Fuel injection nozzles
- Group 25 - Cold weather starting aids

### SECTION 40 — ELECTRICAL SYSTEM

- Group 5 - Diagnosing malfunctions
- Group 10 - "Bilux" lighting system
- Group 15 - Sealed-beam lighting system (on earlier tractor models)
- Group 16 - Sealed-beam lighting system (on later tractor models)
- Group 20 - Starting motor
- Group 25 - Alternator and regulator

### SECTION 50 — POWER TRAIN

- Group 5 - Engine clutches and clutch linkage
- Group 10 - HIGH-LOW shift unit
- Group 15 - Collar-shift transmission
- Group 20 - Differential
- Group 25 - Final drives
- Group 30 - Independent PTO
- Group 35 - Continuous-running PTO

### SECTION 60 — FRONT AXLE, STEERING SYSTEM AND BRAKES

- Group 5 - Front axle
- Group 10 - Steering system
- Group 15 - Hydraulic brakes

### SECTION 70 — HYDRAULIC SYSTEM

- Group 5 - General information, diagnosing malfunctions, and pressure tests
- Group 10 - Oil reservoir, filter, valves and oil cooler
- Group 15 - Hydraulic pump and transmission oil pump
- Group 20 - Rockshaft
- Group 25 - Selective control valves
- Group 30 - Remote cylinder

### SECTION 80 — MISCELLANEOUS

- Group 5 - Belt pulley
- Group 10 - Seats
- Group 15 - Front and rear wheels
- Group 20 - Roll guard

*All information, illustrations, and specifications contained in this technical manual are based on the latest information available at the time of publication. The right is reserved to make changes at any time without notice.*

## INTRODUCTION

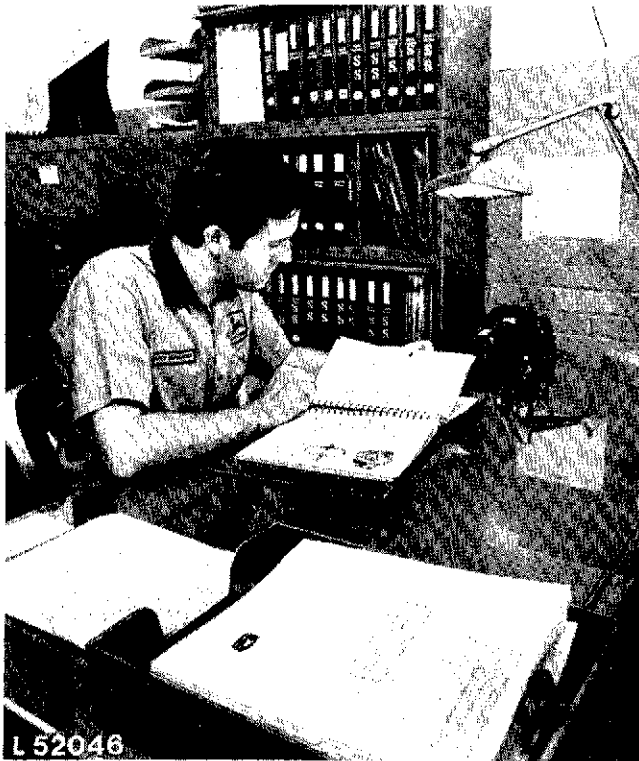

*Use FOS Manuals for Reference*

This technical manual is part of a twin concept of service:

- FOS Manuals — for reference
- Technical Manuals — for actual service

The two kinds of manuals work as a team to give you both the general background and technical details of shop service.

*Fundamentals of Service (FOS) Manuals* cover basic theory of operation, *fundamentals* of trouble shooting, *general* maintenance, and *basic* types of failures and their causes. FOS Manuals are for training new men and for reference by experienced men.

*Technical Manuals* are *concise* service guides for a *specific* machine. Technical Manuals are on-the-job guides containing only the vital information needed by a journeyman mechanic.



When a serviceman should refer to a FOS Manual for more information, a FOS symbol like the one at the left is used in the TM to identify the reference.



*Use Technical Manuals for Actual Service*

Some features of this technical manual:

- *Table of contents at front of whole Manual.*
- *Contents at front of each Section*
- *Exploded views showing parts relationship*
- *Photos showing service techniques*
- *Specifications at end of each Group*
- *Special tools at end of each Group*

This technical manual was planned and written for you — a journeyman mechanic. Keep it in a permanent binder in the shop where it is handy. Refer to it whenever in doubt about correct service procedures or specifications.

Using the technical manual as a guide will reduce error and costly delay. It will also assure you the best in finished service work.



This safety alert symbol indicates important safety messages in this manual. When you see this symbol, be alert to the possibility of personal injury and carefully read the message that follows.

# Section 10 General

## CONTENTS OF THIS SECTION

### GROUP 5 — SPECIFICATIONS

	Page
Serial numbers . . . . .	5-2
Model numbers . . . . .	5-2
Engine . . . . .	5-2
Engine clutch . . . . .	5-2
Electrical system . . . . .	5-2
Transmission . . . . .	5-3
HIGH-LOW shift unit . . . . .	5-3
Differential and final drives . . . . .	5-3
Differential lock . . . . .	5-3
PTO . . . . .	5-3
Hydraulic system . . . . .	5-3
Power steering . . . . .	5-3
Manual steering . . . . .	5-3
Hydraulic brakes . . . . .	5-3
Handbrake . . . . .	5-3
Capacities . . . . .	5-3
Travel speeds . . . . .	5-3
Front and rear wheels . . . . .	5-3
Dimensions and weights . . . . .	5-3

### GROUP 10 — PREDELIVERY, DELIVERY AND AFTER-SALES INSPEC- TIONS

Predelivery inspection . . . . .	10-1
Delivery inspection . . . . .	10-4
After-sales inspection . . . . .	10-4

### GROUP 15 — LUBRICATION AND PERIODIC SERVICE

	Page
Lubrication and periodic service . . . . .	15-1

### GROUP 20 — ENGINE AND TRACTOR TUNE-UP

General information . . . . .	20-1
Preliminary engine testing . . . . .	20-1
Engine tune-up . . . . .	20-2
Checking engine performance . . . . .	20-3
Tractor tune-up . . . . .	20-3
Standard torques . . . . .	20-5
Special tools . . . . .	20-5

### GROUP 25 — TRACTOR SEPARATION

Separating between engine and tractor front end . . . . .	25-1
Removing and installing engine . . . . .	25-3
Removing and installing clutch housing . . . . .	25-5
Removing and installing final drives . . . . .	25-7
Removing and installing rockshaft . . . . .	25-8
Torques for hardware . . . . .	25-9
Special tools . . . . .	25-10

# Group 5 Specifications

## SERIAL NUMBERS

The engine serial number is stamped into the name plate located on the lower front right-hand side of the cylinder block.

*NOTE: If ordering engine parts, indicate all digits of the serial number on the name plate.*

The name plate showing the tractor serial number is located on the right-hand side of the front support.

*NOTE: If ordering tractor parts, (excluding engine parts), indicate all digits of the serial number on the name plate.*

## MODEL NUMBERS

The injection pump, injection nozzles, alternator, starting motor and hydraulic pump have model numbers to facilitate identification of different makes of a given unit.

## SPECIFICATIONS

### ENGINE

Number of cylinders	3
Cylinder liner bore	
1020 and 1120	102 mm (4.02 in.)
1630	106.5 mm (4.19 in.)
Stroke	110 mm (4.33 in.)
Displacement	
1020 and 1120	2688 cm <sup>3</sup> (164 cu.in.)
1630	2938 cm <sup>3</sup> (179 cu.in.)
Compression ratio	
1020 and 1120	16.7 : 1
1630	16.2 : 1
Maximum torque	
1020 at 1500 rpm	15.5 mkp (112 ft.lbs.)
1120 at 1500 rpm	17.0 mkp (123 ft.lbs.)
1630 at 1400 rpm	19.0 mkp (138 ft.lbs.)
Firing order	1 - 2 - 3
Valve clearance (engine hot or cold)	
Intake valve	0.35 mm (0.014 in.)
Exhaust valve	0.45 mm (0.018 in.)

Fast idle	2650 rpm
Slow idle	650 rpm
Working speed range	1500 to 2500 rpm
Flywheel horsepower at 2500 rpm	

1020	1120	1630
46 HP (33.8 kw)*	51 HP (37.5 kw)*	56 HP (41.2 kw)*
48 HP (35.8 kw)**	53 HP (39.6 kw)**	59 HP (44.0 kw)**

\* With accessories (DIN 70020) comprising : water pump, fan, alternator, air cleaner and muffler  
\*\* Less accessories (SAE J 816 b)

PTO horsepower\* at 2500 rpm engine speed and 650/1210 rpm PTO shaft speed

1020	1120	1630
43 PS (31.6 kw)**	48 PS (35.3 kw)**	52 PS (38.2 kw)**
40 HP (29.9 kw)***	45 HP (33.6 kw)***	49 HP (36.6 kw)***

\* With engine run in (more than 100 hours of operation) and having reached operating temperature (engine and transmission); measured by means of a dynamometer. Permissible variation  $\pm 5\%$ .  
\*\* DIN 70020  
\*\*\* SAE J 816 b

### ELECTRICAL SYSTEM

Batteries	2 x 12 volts, 55 ampere-hours
Starting motor	12 volts, 4 HP
Alternator	14 volts, 28 amps.
Battery terminal grounded	negative

### ENGINE CLUTCH

Dual dry disk clutch, foot operated.  
Single dry disk clutch with torsion damper (isolator), foot-operated (on tractors equipped with independent PTO).

**TRANSMISSION**

Collar shift transmission with helical cut gears.

This transmission is available in two variations:

- 8 speed transmission with parking lock, without independent hand brake;
- 8 speed transmission without parking lock and with independent hand brake.

With this transmission 8 forward and 4 reverse speeds are available.

**HIGH-LOW SHIFT UNIT**

Hydraulically controlled reduction gear which can be shifted under load, with "wet" multiple disk clutch and "wet" multiple disk brake. Allows reduction of the individual gear speeds by 21%.

**DIFFERENTIAL AND FINAL DRIVES**

Planetary reduction gear and differential with spiral bevel gears.

**DIFFERENTIAL LOCK**

Hand or foot operated; spring-loaded out of engagement.

**PTO**

*Continuous Running PTO*

The PTO shafts are independent of the transmission if the tractor is equipped with a dual stage engine clutch.

*Independent PTO*

Independent of transmission, can be engaged and disengaged under load.

The independent PTO shaft is engaged by a hydraulically operated disc clutch. Disengaging the clutch is achieved by operating the hydraulically actuated band type brake.

*PTO Shaft Speeds (in rpm)*

Engine Speed rpm	540 rpm shaft	1000 rpm shaft
650	169	315
2067	538	1000
2075	540	1004
2500	650	1210
2650	689	1283

**HYDRAULIC SYSTEM**

Closed center, constant pressure system; also includes rockshaft, power steering and selective control valves.

- Stand-by pressure* . . . . . 156 to 160 kp/cm<sup>2</sup>  
(2220 to 2280 psi)
- Pump* . . . . . 4 or 8-piston pump driven by the engine

**POWER STEERING**

The steering system is a "closed center" type incorporated in the hydraulic system and supplied with oil by the tractor hydraulic pump. It is connected to the front wheels by means of a steering linkage.

**MANUAL STEERING**

The manual steering is a recirculating ball bearing, worm and nut type. A number of steel balls between ball nut and steering wheel shaft provide for positive engagement of steering wheel and steering linkage.

**HYDRAULIC BRAKES**

The disk brakes run in an oil bath and are hydraulically controlled.

**HANDBRAKE**

Band-type locking brake acting on differential.

**CAPACITIES**

	Ltr.	US.gals.	Imp.gals.
<b>Fuel tank</b>			
1020 and 1120 . . . . .	62.5	16.5	13.75
1630 . . . . .	74	19.5	16.3
<b>Cooling system</b>			
1020 and 1120 . . . . .	10.5	2.75	2.3
1630 . . . . .	10	2.6	2.2
<b>Engine crankcase incl. filter . . . . .</b>	5.7	1.5	1.25
<b>Transmission-hydraulic system</b>			
Dry system . . . . .	36.0	9.5	7.9
At service intervals . . . . .	28.0	7.4	6.2
Belt pulley . . . . .	1.1	0.3	0.25

**TRAVEL SPEEDS**

See Operator's Manual.

**FRONT AND REAR WHEELS**

For tire sizes, treads, inflation pressure and weights see Operator's Manual.

**DIMENSIONS AND WEIGHTS**

See Operator's Manual.

## Group 25

# Tractor Separation

### SEPARATING BETWEEN ENGINE AND TRACTOR FRONT END

#### REMOVAL

For safety disconnect ground straps from batteries.

Remove front end weights (if equipped).

Remove radiator cap and fuel tank cap. Remove radiator side grille screens and hood. Install radiator and fuel tank caps.

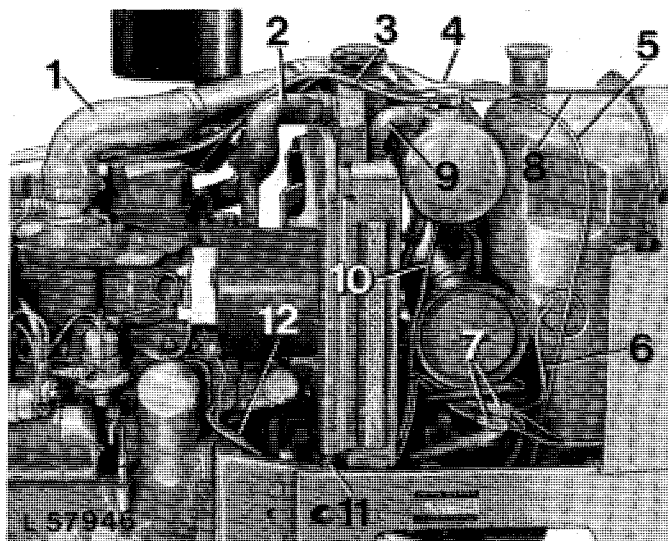

Fig. 1 — Separating between Tractor Front End and Engine

- |                                    |   |
|------------------------------------|---|
| 1 Air intake hose                  | 8 Support rod                                   |
| 2 Upper water hose                 | 9 Hose elbow                                    |
| 3 Leak-off and bleed line          | 10 Air cleaner restriction warning switch cable |
| 4 Fuel return line                 | 11 Oil cooler return line                       |
| 5 Leak-off and bleed line          | 12 Fuel inlet line, tank to fuel transfer pump  |
| 6 Cable of fuel gauge sending unit |   |
| 7 Wire distributor                 |   |

Disconnect air intake hose 1 (fig. 1) at engine intake manifold and at air cleaner.

Disconnect leak-off and bleed lines 3 and 5 at hydraulic oil reservoir.

Remove support rod at top of radiator. Disconnect fuel return line 4 at fuel tank.

Disconnect cable 6 at fuel gauge sending unit.

Disconnect headlight wires at distributors 7.

Disconnect cable 10 at air cleaner restriction warning switch.

Drain coolant and disconnect upper and lower water hoses at radiator.

*Only on tractors equipped with oil cooler:* Remove hose elbow 9 (fig. 1) between hydraulic oil reservoir and oil cooler at oil cooler end. Disconnect return oil line 11 at bottom of oil cooler.

*Only on tractors without oil cooler:* Disconnect hydraulic oil line at top and bottom hose and remove.

*NOTE: Plug lines and openings immediately with plugs or caps to prevent loss of oil and entering of dirt into the system.*

Remove screws securing fan shroud to radiator and slide over fan to the rear.

Remove screws securing radiator to front axle support and lift out radiator to the left of tractor.

Close fuel shut-off valve at bottom of fuel tank.

Disconnect fuel inlet line 12 at fuel tank and fuel transfer pump. Remove transfer pump and fuel inlet line.

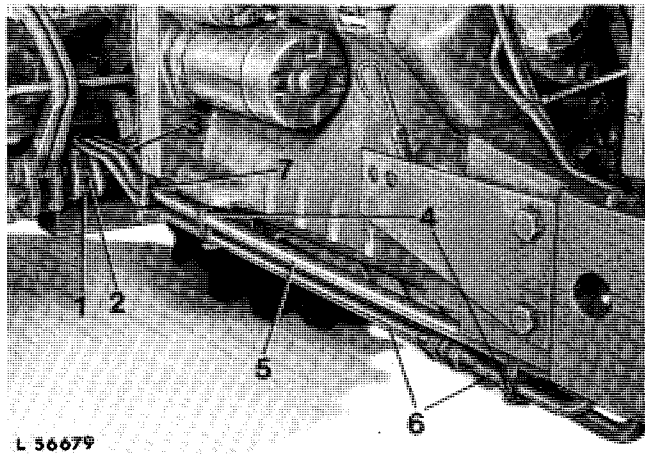

Fig. 2 — Disconnecting Hydraulic Lines

- 1 Retainer
- 2 Cap screw
- 3 Return line to transmission case
- 4 Clamps
- 5 Hydraulic pump inlet line
- 6 Hydraulic pump pressure line
- 7 Power steering pressure line

Remove side frames.

Remove both clamps 4 (fig. 2).

Unscrew cap screw 2 and remove retainer 1 which supports the hydraulic pump inlet line 5 and return line 3 of oil cooler (oil reservoir if not equipped with oil cooler).

*On tractors not equipped with HIGH-LOW shift unit and independent PTO:* Take care that the check valve installed in hydraulic pump inlet line 5 is not lost when the inlet line is removed.

Remove power steering pressure line 7 (if equipped).

Disconnect pressure line 6 at union.

Disconnect drag link at bell crank.

Remove clamping screw of hydraulic pump drive shaft.

Securely support rear of tractor under clutch housing by placing assembly stand 19.58-90.619 under transmission case.

Insert wooden blocks between front axle and front support to prevent the latter from tipping sideways.

Attach front of tractor to a suitable hoist or support with assembly stand 19.58-90.618.

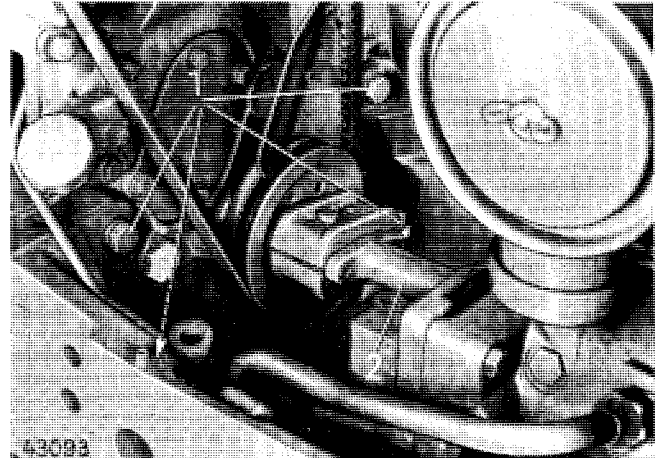

Fig. 3 — Attaching Points of Tractor Front End

- 1 Attaching screws of front axle support
- 2 Hydraulic pump drive shaft

Remove cap screws 1 (fig. 3) of front support and both cap screws located at rear of front support and separate front end from engine. Take measures to prevent front of tractor from tipping forwards. (Drain fuel tank if it contains too much fuel or support tractor front end).

#### INSTALLATION

Make sure Woodruff key is installed in shaft of hydraulic pump.

Move front of tractor towards engine.

Engage pump shaft in hydraulic pump drive shaft and at the same time slide oil cooler return line (reservoir if not equipped with oil cooler) and hydraulic pump inlet line into clutch housing bores and secure both lines (see fig. 2). Tighten cap screw 2 (fig. 2) securing retainer 1 to the specified torque.

**IMPORTANT:** On tractors not equipped with HIGH-LOW shift unit: Ensure check valve is inserted in hydraulic pump inlet line before it is installed.

Attach tractor front end to engine and tighten cap screws to specified torque. Tighten hydraulic pump drive shaft cap screw to specified torque.

*NOTE:* Do not tighten clamping screw of hydraulic pump drive shaft until tractor front end is secured to engine.

Install fuel transfer pump and connect fuel lines.



Make sure transfer pump inlet line is behind and below fuel pressure line.

Open fuel shut-off valve.

Connect cable to fuel gauge sending unit and to air cleaner restriction warning switch.

Connect headlight cables to junctions.

Lift and slide radiator into location from the left side of tractor. Slide fan shroud forward over radiator and secure with screws. Secure radiator to front axle support. Install upper and lower water hoses.

*Only on tractors equipped with oil cooler:* Connect hose elbow between hydraulic oil reservoir and oil cooler at top of oil cooler and return line at bottom of oil cooler (see fig. 1).

*Only on tractors not equipped with oil cooler:* Connect oil line to oil reservoir and tighten both hose clamps (see fig. 1).

Connect leak-off and bleed lines to hydraulic reservoir.

Connect hydraulic pump pressure line and install line clamps (see fig. 2).

Connect air intake pipe at manifold and air cleaner.

Attach drag link to bell crank and tighten slotted nut to specified torque.

Install hood and radiator side grille screens.

Fill radiator with clear, soft water, adding an anti-freeze-rust inhibitor mixture (see Operator's Manual).

Connect battery ground straps.

**IMPORTANT:** Always connect ground straps to negative (-) pole of batteries.

Start engine and check fuel lines, hydraulic lines and water hoses for leaks.

## REMOVING AND INSTALLING ENGINE

*NOTE:* For most engine service operations the engine need not be removed. However, if the crankshaft has to be removed or in case of major overhaul, remove engine.

### REMOVAL

For safety disconnect ground straps from batteries.

Separate tractor front end from engine, as explained previously.

Disconnect cable between, alternator and regulator by removing three-terminal plug at alternator. Disconnect red cable at terminal B+ of alternator.

Disconnect all cables at starting motor (see fig. 4). Disconnect oil pressure switch cable 3 and cable at signal horn.

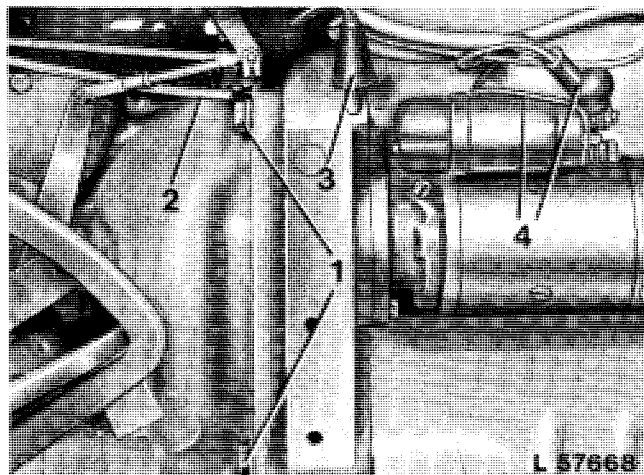

Fig. 4 — Separating between Engine and Clutch Housing, R.H. Side

- |                                      |                               |
|--------------------------------------|-------------------------------|
| 1 Engine attaching screws            | 3 Oil pressure warning switch |
| 2 Flexible shaft of speed-hour meter | 4 Starter cables              |

Disconnect flexible shaft 2 of speed-hour meter at clutch housing and camshaft. If necessary, renew gasket.

*On tractors equipped with starting fluid aid:*  
Disconnect starting fluid line at intake manifold.

*On tractors equipped with thermostart aid:*  
Disconnect cable at heater of intake manifold.

Remove leak-off and bleed line of hydraulic oil reservoir from clamp at rocker arm cover.

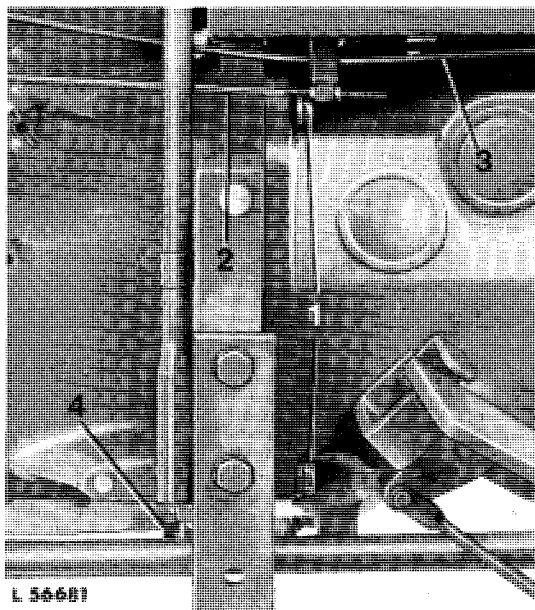

Fig. 5 — Separating between Engine and Clutch Housing, L.H. Side

- 1 Engine attaching screws
- 2 Speed control rod
- 3 Shut-off cable
- 4 Cap screw (2 used) — 1630 only

Disconnect speed control rod 2 and shut-off cable 3 at fuel injection pump.

*On tractors with underneath muffler:* Remove muffler.

Disconnect temperature gauge sensing bulb from cylinder head.

Remove left dash panel as well as both batteries.

Remove cap screws attaching dashboard to flywheel housing.

Attach JD 244-1 and 244-2 engine lifting eyes to cylinder head and attach engine to a suitable hoist.

Remove cap screws 1 (figs. 4 and 5) attaching flywheel housing to clutch housing.

*On 1630 tractors only;* Remove both cap screws 4 (fig. 5) securing oil pan to clutch housing.

Remove engine by means of the hoist.

**IMPORTANT:** Move engine properly in line with drive shaft and hollow drive shaft until these shafts come free of the clutch disks of the engine dual-stage clutch, or free of clutch disk and torsion damper if tractor is equipped with a single-stage clutch.

## INSTALLATION

Align engine properly with drive shaft and hollow drive shaft. Move engine towards rear of tractor. Align splines of both shafts with internal splines of clutch disks (tractor with dual-stage clutch), or (if equipped with a single-stage clutch) with splines of clutch disk and torsion damper. Align screw holes of flywheel housing with holes in clutch housing. Slide engine evenly towards clutch housing. Engage two dowels of flywheel housing in bores of clutch housing until engine is in full contact with clutch housing.

**IMPORTANT:** Make sure flywheel housing is flush against clutch housing before tightening cap screws to specified torque.

*On 1630 tractors only:* Secure oil pan to clutch housing, tightening both cap screws to the specified torque.

Attach dashboard to flywheel housing.

Connect speed control rod and shut-off cable to fuel injection pump.

Insert flexible tube of coolant temperature gauge in cylinder head and tighten retaining screw.

Connect three-terminal plug at alternator and red cable to alternator terminal B+.

Connect cables to starting motor.

Connect cables to signal horn and oil pressure warning switch.

Install both batteries.

**IMPORTANT: Connect battery cable to positive poles of batteries.**

Lubricate gasket of speed-hour meter flexible shaft and attach shaft to clutch housing 2 (fig. 4). Make sure driving tab of flexible shaft engages in slot of camshaft. Do not tighten excessively to avoid damage to the gasket resulting in leakage.

*On tractors equipped with starting fluid aid:* Connect starting fluid line to intake manifold.

*On tractors equipped with thermostart aid:* Connect thermostart aid wire to heater in intake manifold.

*On tractors equipped with underneath muffler:* Install muffler.

Secure oil reservoir leak-off and bleed line to rocker arm cover.

Attach tractor front end to engine.

**IMPORTANT: Connect ground straps of batteries to negative (-) poles.**

*NOTE: If engine has been overhauled, tune up engine as explained in group 20.*

## REMOVING AND INSTALLING CLUTCH HOUSING

*NOTE: Separating and attaching of engine and clutch housing as well as of clutch housing and transmission case is explained below. Where the tractor is to be separated depends on the individual repair operation. If, e.g. repair work has to be carried out on the transmission, separation between the clutch housing and the transmission case will be sufficient.*

### REMOVAL

Disconnect battery ground straps.

Drain transmission oil.

Separate engine from clutch housing as explained under "REMOVING ENGINE", the tractor front end may remain attached to the engine.

Disconnect drag link at steering arm.

Disconnect hydraulic oil reservoir leak-off and bleed line 5 (fig. 6) at transmission shift cover.

Remove clamps 4 (fig. 2), screws 2 and retainer 1 which secure hydraulic pump inlet line and oil cooler return line (oil reservoir if not equipped with oil cooler) to front side of clutch housing.

*On tractors not equipped with HIGH-LOW shift unit and independent PTO:* Take care not to lose check valve installed in hydraulic pump pressure line when latter is removed.

*On tractors equipped with power steering:* Disconnect power steering pressure line at connectors.

*On tractors equipped with a hydraulic trailer brake:* Disconnect pressure line of trailer brake valve at pressure line 3 (fig. 6).

Remove clamp 6 (fig. 6) and hydraulic pump pressure line 3.

Insert wooden blocks between front axle and front support to prevent front support from tipping sideways.

Attach tractor front end and engine to a suitable hoist or support under the engine by means of assembly stand 19.58-90.618. Similarly the rear of tractor should be attached to a suitable hoist or be supported under the transmission case by means of assembly stand 19.58-90.619.

Roll engine and tractor front end away from clutch housing.

**IMPORTANT: Move engine properly in line with drive shaft and hollow drive shaft until these shafts come loose of the clutch disks of the engine dual-stage clutch, or on tractors with single-stage clutch, free of clutch disk and torsion damper.**

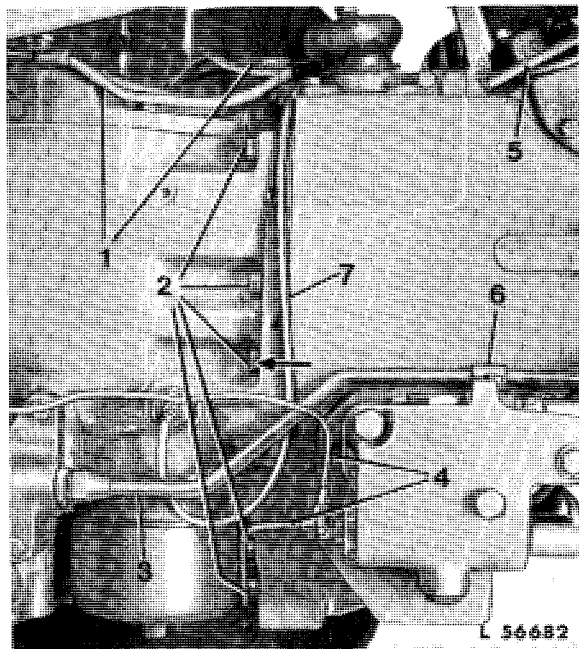

Fig. 6 — Separating between Clutch Housing and Transmission Case, R.H. Side

- |                                   |  |
|-----------------------------------|--|
| 1 Wiring harness                  | 5 Hydraulic oil reservoir<br>leak-off and bleed line                                       |
| 2 Attaching screws                | 6 Clamp  |
| 3 Hydraulic pump<br>pressure line | 7 Transmission oil pressure<br>warning switch cable (tractors<br>with HIGH-LOW shift unit) |
| 4 Brake lines                     |  |

Disconnect brake line 4 (fig. 6) at brake valve.

Remove transmission shield.

Disconnect both harnesses to rear fenders at connectors. Disconnect cable at start safety switch and cables at stop light switch.

*On tractors equipped with HIGH-LOW shift unit:* Disconnect transmission oil pressure warning switch cable 7 (fig. 6). Remove screws 3 (fig. 7). Disconnect connecting rod 5 from lever shaft and remove cover 4 complete with lever shaft and control arm.

*On tractors equipped with independent PTO:* Before removing cover 4 (fig. 7), move PTO shift lever in engaged position. After cover 4 has been removed, do not move PTO shift lever otherwise lock balls and springs will drop out of cover.

Remove screws attaching transmission shift cover to clutch housing. Remove transmission shift cover complete with gear shift levers.

Remove transmission oil filter. On tractors equipped with a connection for an external hydraulic motor: First disconnect hydraulic motor return line at elbow connector on transmission oil filter, then screw elbow connector out of transmission oil filter.

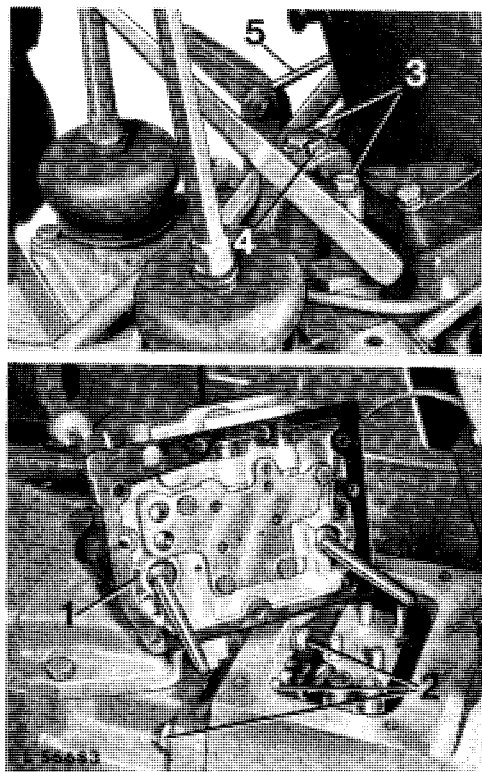

Fig. 7 — Removing Gear Shift Cover

- |                                      |                    |
|--------------------------------------|--------------------|
| 1 Shift cover                        | 3 Attaching screws |
| 2 Clutch housing<br>attaching points | 4 Cover            |
|                                      | 5 Connecting rod   |

Remove cap screws 2 (figs. 6 and 7) securing clutch housing to transmission case, and separate clutch housing from transmission case.

Discard seal rings provided between the two housings.

*On tractors with continuous-running PTO:* Be sure ball and spring provided on some PTO shaft types do not get lost (see section 50, group 35).

#### INSTALLATION

Install new seal rings in clutch housing front facing transmission case.

Slide clutch housing toward transmission case.

Slide PTO shaft into needle bearing of front PTO shaft or, if not equipped with a front PTO, into needle bearing of clutch housing quill.

*On tractors with continuous-running PTO:* Make sure spring and ball provided on some PTO types are installed in PTO drive shaft or clutch housing quill.

Align clutch housing with centerline of PTO drive shaft and slide against transmission case. Mesh PTO gears.

Make sure clutch housing is flush against transmission case before tightening cap screws to the specified torque.

*NOTE: Before inserting the third retaining screw in clutch housing (see arrow, fig. 6) coat it with a film of oil-resistant sealant.*

*NOTE: If clutch housing has also been separated from engine, assemble as explained under "Installation of Engine"*

Insert hydraulic pump inlet line 5 (fig. 2) and oil cooler return line 3\* in bore of clutch housing and secure by means of screw and retainer. Tighten screw to specified torque.

\* Oil reservoir when not equipped with oil cooler.

*On tractors not equipped with HIGH-LOW shift unit and independent PTO:* Ensure check valve is installed in feed line to hydraulic pump before connecting.

Connect hydraulic pump pressure line.

*On tractors equipped with power steering:* Connect power steering pressure line.

As regards further installation operations reverse removal procedure.

**IMPORTANT:** Connect ground straps of batteries to negative (-) poles.

## REMOVING AND INSTALLING OF FINAL DRIVES

### REMOVAL

*NOTE: The removal of both final drives is explained below. If only one final drive is to be removed, remove only one wheel, wiring harness etc.*

For safety disconnect ground strap at batteries.

Lift up rear of tractor by means of a suitable jack or hoist and remove rear wheels.



**CAUTION:** Support transmission safely to prevent tipping of tractor.

Disconnect both rear wiring harnesses at connectors.

Remove rear fenders and roll-over guard.

Disconnect cables at stop light switch located in left-hand rear axle housing.

Disconnect brake lines on both rear axle housings.

*On tractors equipped with selective control valve (s):* Disconnect hydraulic lines and remove selective control valve(s) from right-hand final drive assembly.

Cover connections and exposed openings with plastic plugs or caps to prevent particles of dirt from entering the system.

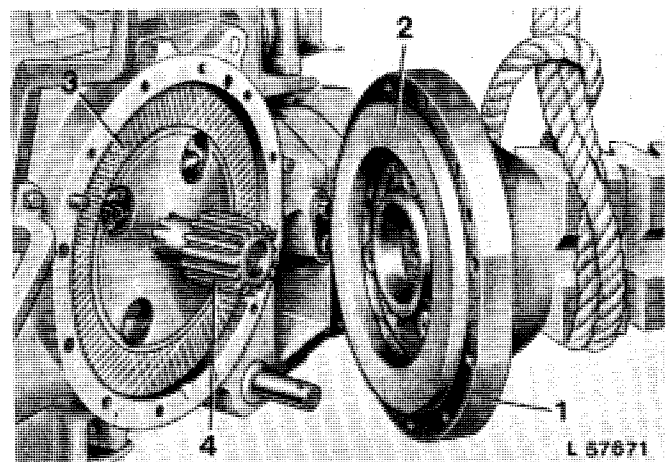

Fig. 8 — Removing Final Drive

- 1 Final drive housing
- 2 Pressure ring
- 3 Brake disk
- 4 Final drive shaft

Attach final drive to hoist. Remove final drive attaching screws and pull final drive housing from transmission case. Withdraw housing evenly until final drive shaft gear is no longer in mesh with planetary gears of final drive.

## INSTALLATION

*NOTE: If the brake disk was removed, install bonded two-layer facing so that the brass-interwoven upper layer faces the brake surface of the transmission case.*

Position new gaskets between rear axle housing and transmission case.

Attach final drive to transmission case by means of a suitable hoist. Make sure final drive shaft gear engages with planetary gears and that the dowels are properly aligned.

Tighten final drive attaching screws to the specified torque.

*On tractors with selective control valve (s):* Attach control valves onto the right hand final drive housing. Connect hydraulic lines.

Connect brake lines and bleed brakes, as explained in section 60, group 15.

Install rear fenders and roll guard. Tighten hex nuts to specified torque.

Connect wiring harnesses.

Connect cable to brake warning switch.

Install rear wheels and tighten to the specified torque.

**IMPORTANT: Connect ground straps to negative (-) poles of batteries.**

## REMOVING AND INSTALLING ROCKSHAFT

### REMOVAL

**IMPORTANT:** Work on the hydraulic system requires extreme care and cleanliness. Minute dirt or foreign particles, scratches, nicks or burrs may put the hydraulic system out of function. Before removing the rockshaft, check hydraulic system for leaks.

For safety, disconnect ground straps from batteries.

Remove transmission shield. Disconnect cable 1 (fig. 9) of start safety switch.

Remove operator's seat. Disconnect both lift links at lift arms.

Disconnect oil return line 2 (fig. 9), if equipped, at union on rockshaft.

Disconnect lines 3 to rear quick couplers (if equipped) at selective control valves.

Free both rear wiring harnesses 4.

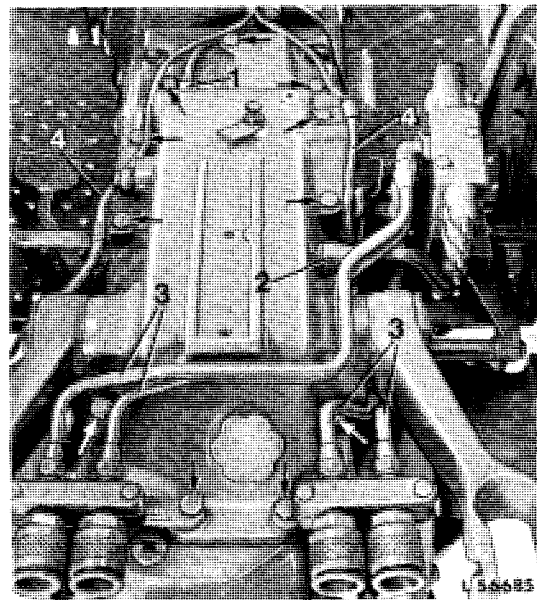

Fig. 9 — Rockshaft, Installed

- 1 Cable of start safety switch
- 2 Oil return line
- 3 Lines to quick couplers
- 4 Wiring harnesses

Move selector lever in position "L" (load control) so that the control linkage roller slides along the cam of the control arm when removing the rockshaft.

Attach engine lifting eye No. JD 244-2 to top of rockshaft housing.

Remove rockshaft attaching screws (see arrows in fig. 9). Lift rockshaft assembly off transmission case by means of a hoist.

Take care not damage both rear harnesses.

*NOTE: After removing rockshaft, cover transmission case to prevent foreign particles from falling into the transmission.*

### INSTALLATION

Use a new gasket between transmission case and rockshaft. Make sure dowels in transmission case and seal ring of oil inlet passage are installed.

Move selector lever in position "L" so that the control linkage with roller can be slid over the cam.

Lift rockshaft on transmission case, using a suitable hoist.

If equipped: connect oil return line 2 (fig. 9) of selective control valve to rockshaft housing.

Connect lines to quick couplers.

Tighten rockshaft attaching screws to the specified torque.

Connect cable of start safety switch.

Connect both rear wire harnesses to rockshaft. Install transmission shield on transmission case.

Attach lift links to lift arms. Install operator's seat.

For adjustment of rockshaft see section 70, group 20.

**IMPORTANT: Connect ground straps to negative (-) poles of batteries.**

### TORQUES FOR HARDWARE

Front support to engine, cap screws		
front cap screws (4 used) . . . . .	23.5 mkp	170 ft.lbs.
rear cap screws (2 used) . . . . .	18.0 mkp	130 ft.lbs.
Hydraulic pump drive shaft, clamping screw . . . . .	4.4 mkp	32 ft.lbs.
Drag link to bell crank or steering arm, slotted nut* . . . . .	7.7 mkp	55 ft.lbs.
Clutch housing to engine, cap screws . . . . .	23.5 mkp	170 ft.lbs.
Oil pan to clutch housing (1630 only), cap screws . . . . .	23.5 mkp	170 ft.lbs.
Clutch housing to transmission, cap screws . . . . .	11.7 mkp	85 ft.lbs.
Retainer securing hydraulic lines to clutch housing, cap screw . . . . .	4.5 mkp	32 ft.lbs.
Final drive housings to transmission case, cap screws . . . . .	11.7 mkp	85 ft.lbs.
Roll guard to final drive housings, securing bracket, hex. nuts . . . . .	13 mkp	94 ft.lbs.

\* *NOTE: If cotter pin cannot be inserted when tightening to the specified torque, turn nut to next slot and secure with cotter pin.*

**TORQUES FOR HARDWARE (Continued)**

Rockshaft housing to transmission case, cap screws . . . . .	11.7 mkp	85 ft.lbs.
Rear wheels to rear axle, ball nuts . . . . .	41.5 mkp	300 ft.lbs.
Wheel disc to hub (on tractors equipped with rack-and-pinion axle), wheel securing bolts . . . . .	41.5 mkp	300 ft.lbs.

**SPECIAL TOOLS**

Part No. when ordering from		Description	Use
JD Parts Depot	Manufacturer		
L 48524 . . . . .	JD 244-1** . . . . .	Lifting eye, straight . . . . .	Removing and installing assemblies
L 48525 . . . . .	JD 244-2** . . . . .	Lifting eye, bent . . . . .	Ditto
19.58-90.618 . . . . .		Assembly stand . . . . .	Separating tractor front end and engine.
19.58-90.619 . . . . .		Assembly stand . . . . .	Ditto

\*\* SERVICE TOOLS INC., 1901 INDIANA AVENUE, ILLINOIS 60616, USA



**Thank you very much for  
your reading. Please Click  
Here. Then Get COMPLETE  
MANUAL. NO WAITING**



**NOTE:**

**If there is no response to  
click on the link above,  
please download the PDF  
document first and then  
click on it.**

# Section 20

# Engine

## CONTENTS OF THIS SECTION

GROUP 5 — GENERAL INFORMATION, DIAGNOSING MALFUNCTIONS		GROUP 25 — TIMING GEAR TRAIN		Page
	Page	General information . . . . .		25-1
General information . . . . .	5-2	Removal . . . . .		25-1
Diagnosing malfunctions . . . . .	5-2	Repair . . . . .		25-2
		Installation . . . . .		25-3
		Specifications . . . . .		25-5
		Torques for hardware . . . . .		25-6
		Special tools . . . . .		25-6
GROUP 10 — CYLINDER HEAD AND CAMSHAFT		GROUP 30 — OIL PUMP, OIL PRESSURE REGULATING VALVE, OIL COOLER AND OIL FILTER		
General information . . . . .	10-1	General information . . . . .		30-1
Cylinder head . . . . .	10-1	Removal . . . . .		30-2
Removal . . . . .	10-1	Repair . . . . .		30-2
Repair . . . . .	10-1	Installation . . . . .		30-4
Installation . . . . .	10-4	Adjusting engine oil pressure . . . . .		30-5
Adjusting valve clearance . . . . .	10-4	Specifications . . . . .		30-6
Camshaft . . . . .	10-5	Torques for hardware . . . . .		30-6
Removal . . . . .	10-5	Special tools . . . . .		30-6
Repair . . . . .	10-5			
Installation . . . . .	10-6			
Specifications . . . . .	10-7			
Torques for hardware . . . . .	10-9			
Special tools . . . . .	10-9			
GROUP 15 — CYLINDER BLOCK, LINERS, PISTONS AND CONNECTING RODS		GROUP 35 — COOLING SYSTEM		
General information . . . . .	15-1	General information . . . . .		35-1
Removal . . . . .	15-1	Diagnosing malfunctions . . . . .		35-2
Repair . . . . .	15-1	Repair . . . . .		35-2
Assembly . . . . .	15-4	Radiator . . . . .		35-2
Installation . . . . .	15-4	Adjusting fan belt . . . . .		35-2
Specifications . . . . .	15-7	Water pump . . . . .		35-2
Torques for hardware . . . . .	15-10	Checking thermostat . . . . .		35-4
Engine break-in . . . . .	15-11	Specifications . . . . .		35-5
Tune-up data . . . . .	15-11	Torques for hardware . . . . .		35-5
Special tools . . . . .	15-11	Special tools . . . . .		35-5
GROUP 20 — CRANKSHAFT, MAIN BEARINGS AND FLYWHEEL		GROUP 40 — SPEED CONTROL LINKAGE		
General information . . . . .	20-1	General information . . . . .		40-1
Removal . . . . .	20-1	Removal and disassembly . . . . .		40-1
Repair . . . . .	20-1	Repair . . . . .		40-3
Installation . . . . .	20-4	Assembly and installation . . . . .		40-3
Specifications . . . . .	20-6	Adjustment . . . . .		40-4
Torques for hardware . . . . .	20-7	Specifications . . . . .		40-5
Special tools . . . . .	20-7			

## Group 5

# General Information, Diagnosing Malfunctions

### GENERAL INFORMATION

The tractor is equipped with a 3-cylinder vertical in-line, valve-in-head, 4-cycle Diesel engine with direct fuel injection. The "wet" cylinder liners can be replaced one at a time. The pistons are of forged aluminium alloy and cam-ground. Each piston has two single, cast-iron compression rings and one oil control ring. All ring grooves are above the piston pin. The case-hardened piston pins are full floating and are each held in place by two snap rings.

The crankshaft is a one-piece, heat-treated, steel forging. It is supported in four replaceable two-piece main bearings machined to close tolerances.

The connecting rods are provided with a bronze bushing and a two-piece, replaceable bearing cap each.

A camshaft supported in the cylinder block controls the valves and drives the fuel transfer pump.

The intake and exhaust valves are supported in the cylinder head. The valve stems slide in bores in the cylinder head. The rocker arm shaft assembly is fitted on top of the cylinder head.

The engine is supplied with lubricating oil by a gear pump. The lubricating oil passes through a full-flow oil filter in the main oil circuit. To ensure engine lubrication, the oil filter is provided with a by-pass valve which opens when the filter element is restricted. On 1630 tractors lubricating oil is cooled by means of an oil cooler.

The engine has a pressure cooling system consisting of the radiator, water pump, multi-blade fan and thermostat.

### DIAGNOSING MALFUNCTIONS

#### ENGINE WILL NOT CRANK

Dead batteries

Bad battery connections

Defective key switch or start safety switch

Starting motor solenoid defective

Starting motor defective

#### ENGINE HARD TO START OR WILL NOT START

Loose or corroded battery connections  
Low battery output

Excessive resistance in starter circuit

Too high viscosity crankcase oil

Water, dirt or air in fuel system

Fuel filter restricted

Stuck shut-off knob

Dirty or faulty fuel injection nozzles

Defective injection pump

Defective fuel transfer pump

Shut-off valve at fuel tank closed

Injection pump out of time

#### ENGINE RUNS IRREGULARLY OR STALLS FREQUENTLY

Coolant temperature too low

Insufficient fuel supply

Injection nozzles defective or leaking