

42 Bale Ejector

John Deere Ottumwa Works
TM1584 (07MAY01)

LITHO IN U.S.A.
ENGLISH

Introduction

FOREWORD

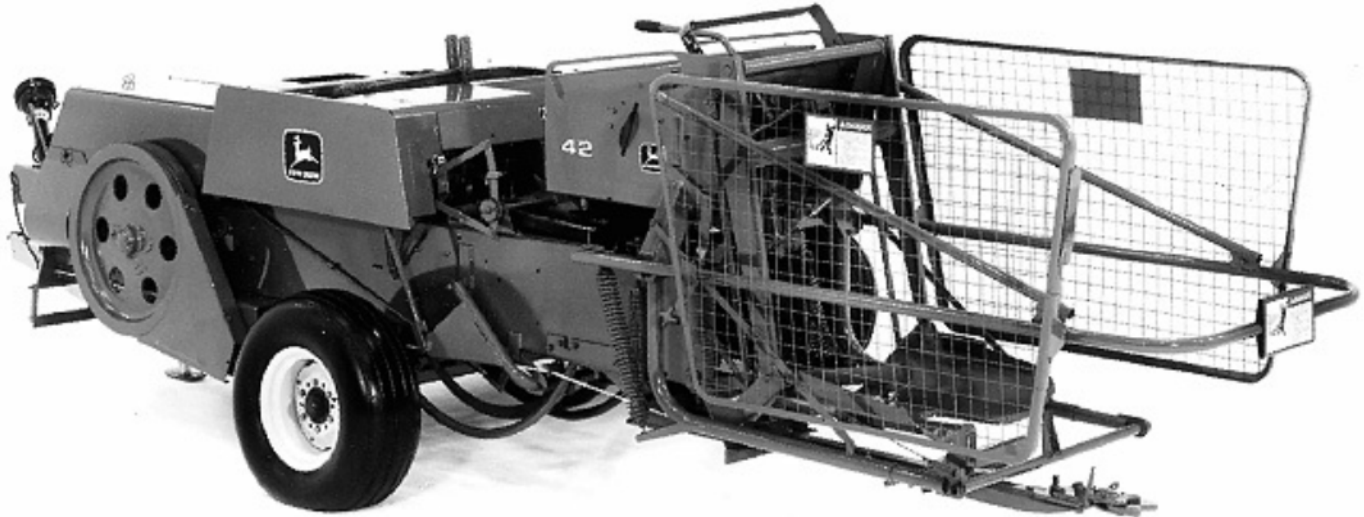

E38170 -JUN-01/JUN94

42 Bale Ejector on a 338 Baler

This manual is written for an experienced technician. Essential tools required in performing certain service work are identified in this manual and are recommended for use.

Live with safety: Read the safety messages in the introduction of this manual and the cautions presented throughout the text of the manual.

 This is the safety-alert symbol. When you see this symbol on the machine or in this manual, be alert to the potential for personal injury.

Technical manuals are divided in two parts: repair and operation and tests. Repair sections tell how to repair the components. Operation and tests sections help you identify the majority of routine failures quickly.

Information is organized in groups for the various components requiring service instruction. At the beginning of each group are summary listings of all applicable essential tools, service equipment and tools, other materials needed to do the job, service parts kits, specifications, wear tolerances, and torque values.

Technical Manuals are concise guides for specific machines. They are on-the-job guides containing only the vital information needed for diagnosis, analysis, testing, and repair.

Fundamental service information is available from other sources covering basic theory of operation, fundamentals of troubleshooting, general maintenance, and basic type of failures and their causes.

EX, TM1584, IFC -19-25MAR96

Contents

SECTION 10—GENERAL

- Group 05—Safety
- Group 10—Machine Description
- Group 15—Specifications and Torques
- Group 20—Lubrication

SECTION 20—ELECTRICAL SYSTEM

- Group 05—Diagnosing Malfunctions
- Group 10—General Information and Wiring Diagrams
- Group 15—Console Control

SECTION 30—HYDRAULIC SYSTEM

- Group 05—General Information
- Group 10—Diagnosing Malfunctions
- Group 15—Hydraulic System Tests
- Group 20—Hydraulic Pump
- Group 25—Control Valve
- Group 30—Throwing Cylinder
- Group 35—Tilt Cylinder
- Group 40—Latch Cylinder

SECTION 40—EJECTOR

- Group 05—General Information

Index

All information, illustrations and specifications in this manual are based on the latest information available at the time of publication. The right is reserved to make changes at any time without notice.

TM1584-19-07MAY01

COPYRIGHT© 1996
DEERE & COMPANY
Moline, Illinois
All rights reserved
A John Deere ILLUSTRATION® Manual
Previous Editions
Copyright 1995 Deere & Company

Contents

Page

Group 05—Safety

Group 10—Machine Description

General Description 10-10-1

Group 15—Specifications and Torques

Specifications 10-15-1

Group 20—Lubrication

Lubricate Bale Ejector Properly 10-20-1

Grease 10-20-2

Hydraulic Oil 10-20-2

Intervals 10-20-3

Control Valve 10-20-3

RECOGNIZE SAFETY INFORMATION

This is the safety-alert symbol. When you see this symbol on your machine or in this manual, be alert to the potential for personal injury.

Follow recommended precautions and safe operating practices.



DX,ALERT -19-03MAR93

T81389 -UN-07DEC88

UNDERSTAND SIGNAL WORDS

A signal word—DANGER, WARNING, or CAUTION—is used with the safety-alert symbol. DANGER identifies the most serious hazards.

DANGER or WARNING safety signs are located near specific hazards. General precautions are listed on CAUTION safety signs. CAUTION also calls attention to safety messages in this manual.



DX,SIGNAL -19-03MAR93

TS187 -19-30SEP88

FOLLOW SAFETY INSTRUCTIONS

Carefully read all safety messages in this manual and on your machine safety signs. Keep safety signs in good condition. Replace missing or damaged safety signs. Be sure new equipment components and repair parts include the current safety signs. Replacement safety signs are available from your John Deere dealer.

Learn how to operate the machine and how to use controls properly. Do not let anyone operate without instruction.

Keep your machine in proper working condition. Unauthorized modifications to the machine may impair the function and/or safety and affect machine life.

If you do not understand any part of this manual and need assistance, contact your John Deere dealer.

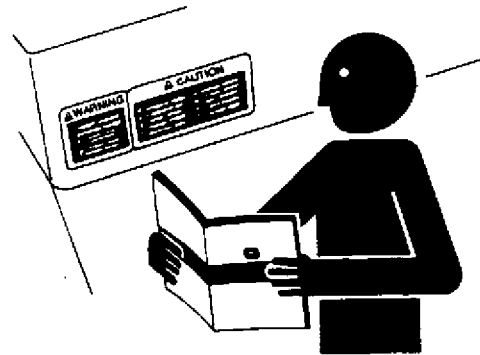

DX,READ -19-03MAR93

TS201 -UN-23AUG88

10
0510
2

HANDLE FLUIDS SAFELY—AVOID FIRES

When you work around fuel, do not smoke or work near heaters or other fire hazards.

Store flammable fluids away from fire hazards. Do not incinerate or puncture pressurized containers.

Make sure machine is clean of trash, grease, and debris.

Do not store oily rags; they can ignite and burn spontaneously.



DX,FLAME -19-04JUN90

TS227 -UN-23AUG88

PREPARE FOR EMERGENCIES

Be prepared if a fire starts.

Keep a first aid kit and fire extinguisher handy.

Keep emergency numbers for doctors, ambulance service, hospital, and fire department near your telephone.

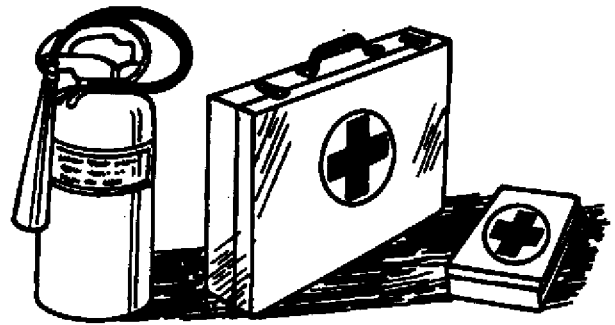

DX,FIRE2 -19-03MAR93

TS291 -UN-23AUG88

AVOID HIGH-PRESSURE FLUIDS

Escaping fluid under pressure can penetrate the skin causing serious injury.

Avoid the hazard by relieving pressure before disconnecting hydraulic or other lines. Tighten all connections before applying pressure.

Search for leaks with a piece of cardboard. Protect hands and body from high pressure fluids.

If an accident occurs, see a doctor immediately. Any fluid injected into the skin must be surgically removed within a few hours or gangrene may result. Doctors unfamiliar with this type of injury should reference a knowledgeable medical source. Such information is available from Deere & Company Medical Department in Moline, Illinois, U.S.A.

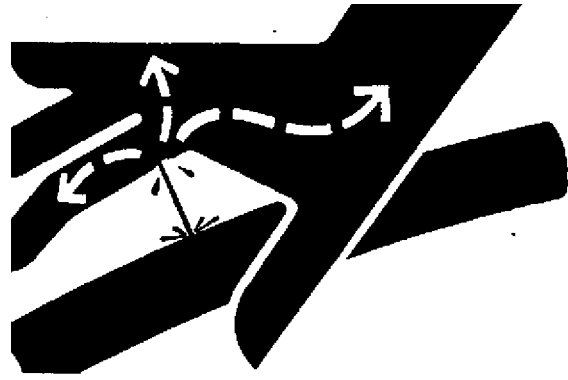

DX,FLUID -19-03MAR93

10
3
95
-UN-23AUG88

X9811

SUPPORT MACHINE PROPERLY

Always lower the attachment or implement to the ground before you work on the machine. If you must work on a lifted machine or attachment, securely support the machine or attachment.

Do not support the machine on cinder blocks, hollow tiles, or props that may crumble under continuous load. Do not work under a machine that is supported solely by a jack. Follow recommended procedures in this manual.

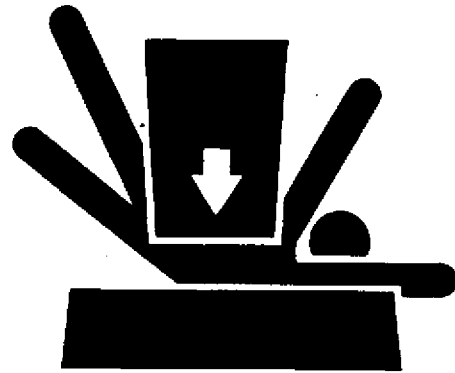

DX,LOWER -19-04JUN90

-UN-23AUG88

TS229

10
05
4

WEAR PROTECTIVE CLOTHING

Wear close fitting clothing and safety equipment appropriate to the job.

Prolonged exposure to loud noise can cause impairment or loss of hearing.

Wear a suitable hearing protective device such as earmuffs or earplugs to protect against objectionable or uncomfortable loud noises.

Operating equipment safely requires the full attention of the operator. Do not wear radio or music headphones while operating machine.

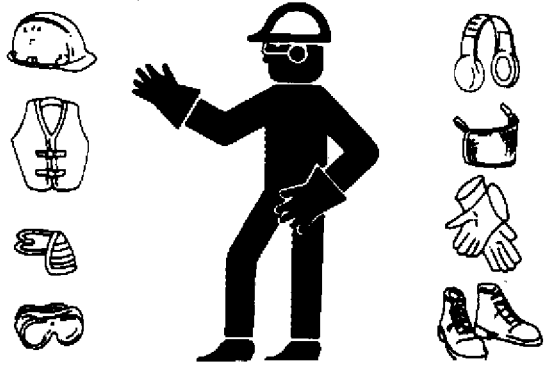

DX,WEAR -19-10SEP90

TS206 -UN-23AUG88

SERVICE MACHINES SAFELY

Tie long hair behind your head. Do not wear a necktie, scarf, loose clothing, or necklace when you work near machine tools or moving parts. If these items were to get caught, severe injury could result.

Remove rings and other jewelry to prevent electrical shorts and entanglement in moving parts.

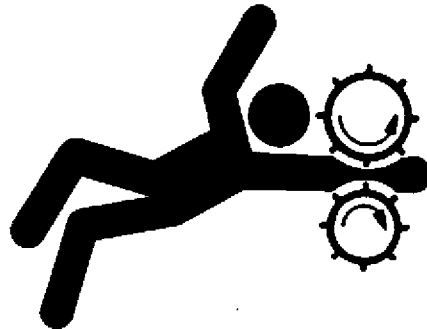

DX,LOOSE -19-04JUN90

TS228 -UN-23AUG88

WORK IN VENTILATED AREA

Engine exhaust fumes can cause sickness or death. If it is necessary to run an engine in an enclosed area, remove the exhaust fumes from the area with an exhaust pipe extension.

If you do not have an exhaust pipe extension, open the doors and get outside air into the area.

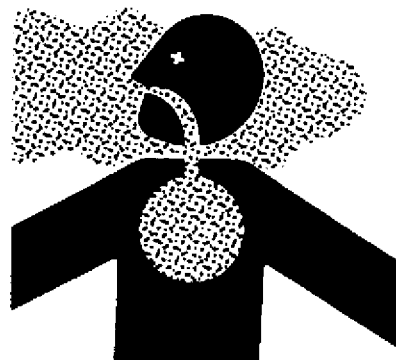

DX,AIR -19-04JUN90

TS220 -UN-23AUG88

WORK IN CLEAN AREA

Before starting a job:

- Clean work area and machine.
- Make sure you have all necessary tools to do your job.
- Have the right parts on hand.
- Read all instructions thoroughly; do not attempt shortcuts.

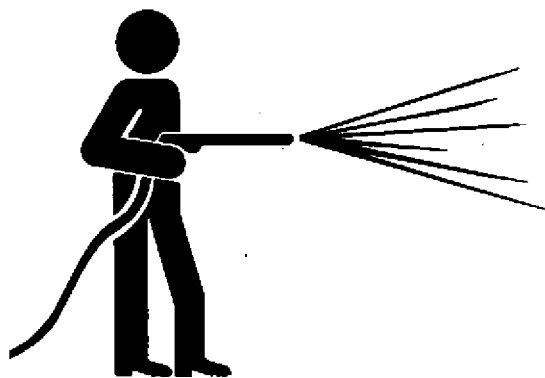

DX,CLEAN -19-04JUN90

T6642EJ -UN-18OCT88

51910

REMOVE PAINT BEFORE WELDING OR HEATING

Avoid potentially toxic fumes and dust.

Hazardous fumes can be generated when paint is heated by welding, soldering, or using a torch.

Do all work outside or in a well ventilated area. Dispose of paint and solvent properly.

Remove paint before welding or heating:

- If you sand or grind paint, avoid breathing the dust. Wear an approved respirator.
- If you use solvent or paint stripper, remove stripper with soap and water before welding. Remove solvent or paint stripper containers and other flammable material from area. Allow fumes to disperse at least 15 minutes before welding or heating.

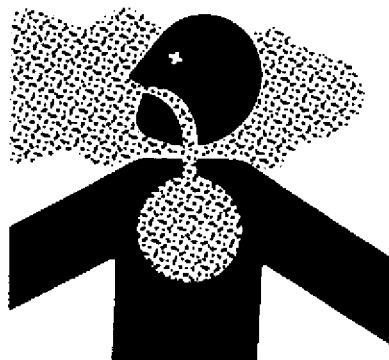

DX,PAINT -19-03MAR93

TS220 -UN-23AUG88

AVOID HEATING NEAR PRESSURIZED FLUID LINES

Flammable spray can be generated by heating near pressurized fluid lines, resulting in severe burns to yourself and bystanders. Do not heat by welding, soldering, or using a torch near pressurized fluid lines or other flammable materials. Pressurized lines can be accidentally cut when heat goes beyond the immediate flame area.



DX,TORCH -19-03MAR93

TS953 -UN-15MAY90

ILLUMINATE WORK AREA SAFELY

Illuminate your work area adequately but safely. Use a portable safety light for working inside or under the machine. Make sure the bulb is enclosed by a wire cage. The hot filament of an accidentally broken bulb can ignite spilled fuel or oil.



DX,LIGHT -19-04JUN90

TS223 -UN-23AUG88

REPLACE SAFETY SIGNS

Replace missing or damaged safety signs. See the machine operator's manual for correct safety sign placement.

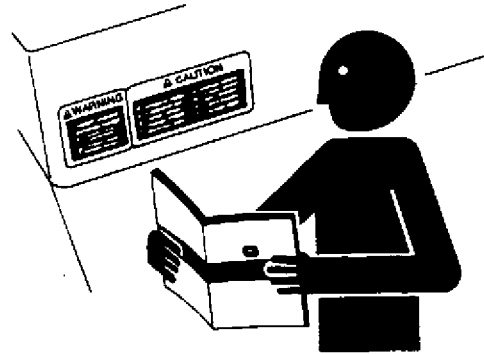

DX,SIGNS1 -19-04JUN90

TS201 -UN-23AUG88

USE PROPER LIFTING EQUIPMENT

Lifting heavy components incorrectly can cause severe injury or machine damage.

Follow recommended procedure for removal and installation of components in the manual.

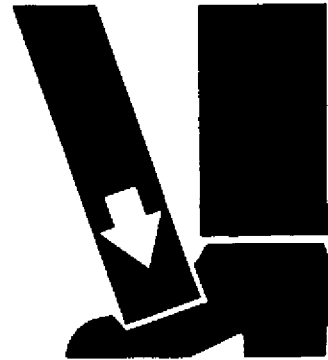

DX,LIFT -19-04JUN90

TS226 -UN-23AUG88

PRACTICE SAFE MAINTENANCE

Understand service procedure before doing work. Keep area clean and dry.

Never lubricate, service, or adjust machine while it is moving. Keep hands, feet, and clothing from power-driven parts. Disengage all power and operate controls to relieve pressure. Lower equipment to the ground. Stop the engine. Remove the key. Allow machine to cool.

Securely support any machine elements that must be raised for service work.

Keep all parts in good condition and properly installed. Fix damage immediately. Replace worn or broken parts. Remove any buildup of grease, oil, or debris.

Disconnect battery ground cable (-) before making adjustments on electrical systems or welding on machine.



DX,SERV -19-03MAR93

TS218 -UN-23AUG88

USE PROPER TOOLS

Use tools appropriate to the work. Makeshift tools and procedures can create safety hazards.

Use power tools only to loosen threaded parts and fasteners.

For loosening and tightening hardware, use the correct size tools. DO NOT use U.S. measurement tools on metric fasteners. Avoid bodily injury caused by slipping wrenches.

Use only service parts meeting John Deere specifications.



DX,REPAIR -19-04JUN90

TS779 -UN-08NOV89

10
0510
8

DISPOSE OF WASTE PROPERLY

Improperly disposing of waste can threaten the environment and ecology. Potentially harmful waste used with John Deere equipment include such items as oil, fuel, coolant, brake fluid, filters, and batteries.

Use leakproof containers when draining fluids. Do not use food or beverage containers that may mislead someone into drinking from them.

Do not pour waste onto the ground, down a drain, or into any water source.

Air conditioning refrigerants escaping into the air can damage the Earth's atmosphere. Government regulations may require a certified air conditioning service center to recover and recycle used air conditioning refrigerants.

Inquire on the proper way to recycle or dispose of waste from your local environmental or recycling center, or from your John Deere dealer.

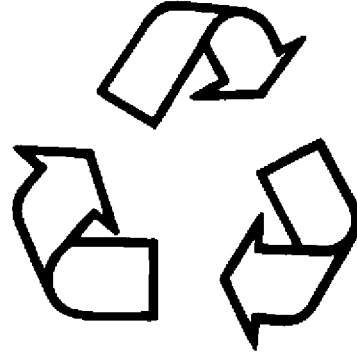

TS1133 -UN-26NOV90

DX,DRAIN -19-03MAR93

LIVE WITH SAFETY

Before returning machine to customer, make sure machine is functioning properly, especially the safety systems. Install all guards and shields.



TS231 -19-07OCT88

DX,LIVE -19-25SEP92

SAFETY SIGNS



E38177 -UN-13OCT94



E38178 -UN-13OCT94

⚠ DANGER

TO AVOID PERSONAL INJURY:

1. Before hitching wagon to baler or working in or around ejector:
 - (a) Disengage tractor P.T.O.
 - (b) Wait until baler flywheel has stopped turning as it powers ejector.
 - (c) Raise side shields. Ensure lockout lever is in lockout position.
2. Never stand behind ejector while baler is operating.
3. Keep side screens lowered while operating.

E38270 -19-27OCT94

E05614

The diagram shows a person standing behind a baler's ejector. A dashed arrow indicates the path of a moving part that could strike the person. The person is shown in a falling or being struck posture.

EX,42BEC,A2 -19-19SEP95

GENERAL DESCRIPTION

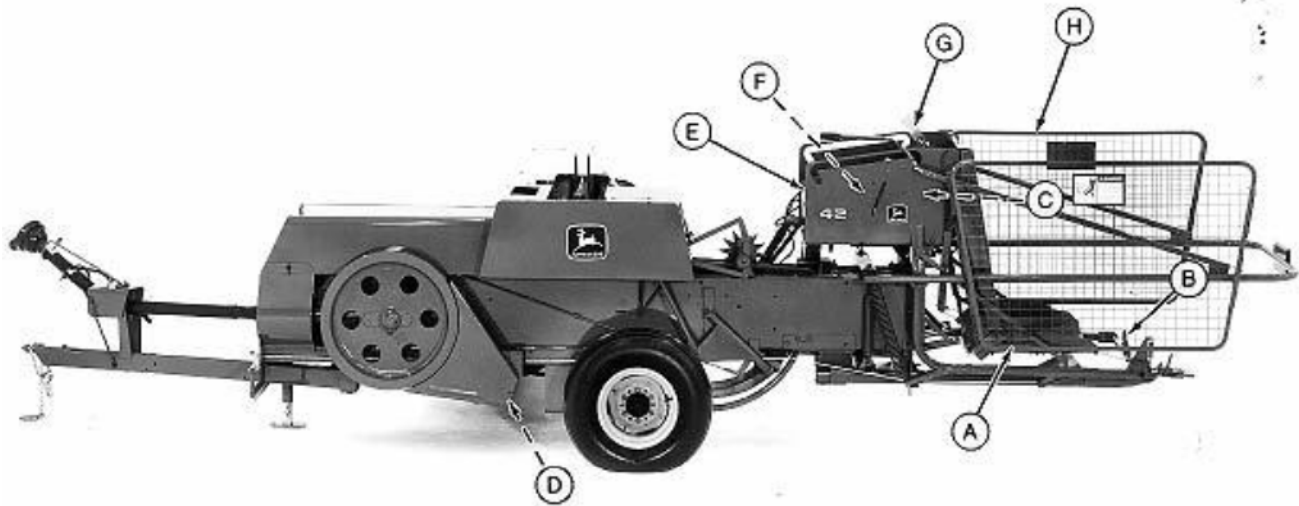

E38171 -UN-01JUN94

- As the bale moves from the bale chamber onto the throwing pan (A), it will trip pedal (B) activating the hydraulic control valve (C). The trip pedal support is adjustable, allowing for different length bales.

- The hydraulic pump (D) is operated by the flywheel. The pump draws hydraulic fluid from the reservoir (E) sending it to the control valve. The fluid flows from the valve back to the reservoir until the control valve is activated. When activated, the control valve pressurizes the system causing the throwing pan to eject the bale.

- The distance control is operated by a electric motor (F). The electric motor operates the relief valve, increasing or decreasing relief pressure, in the control valve. The relief valve determines the amount of pressure in the system, the more pressure, the farther the bale is thrown.

- The bale ejector can be tilted to the right or left, allowing the operator to aim the ejected bale as needed. The tilt is controlled either hydraulically or electrically. The tractor SCV valve operates the hydraulic tilt.

- When the lockout lever (G) is engaged, it prevents the activation of the hydraulic control valve. When the side screens (H) are raised, for access to the throwing pan, the lockout lever is mechanically engaged.

- See OPERATE THE SIDE SCREENS in this section, this group.

EX,1584,1010,A -19-25MAR96

**Thank you very much for
your reading. Please Click
Here. Then Get COMPLETE
MANUAL. NO WAITING**



NOTE:

**If there is no response to
click on the link above,
please download the PDF
document first and then
click on it.**

OPERATE THE SIDE SCREENS

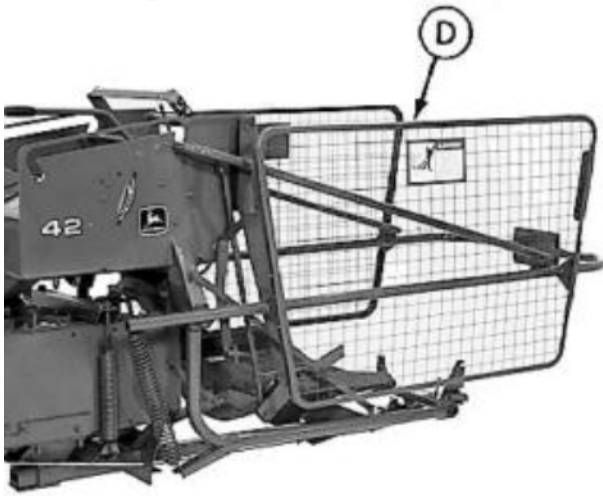

Operating Position

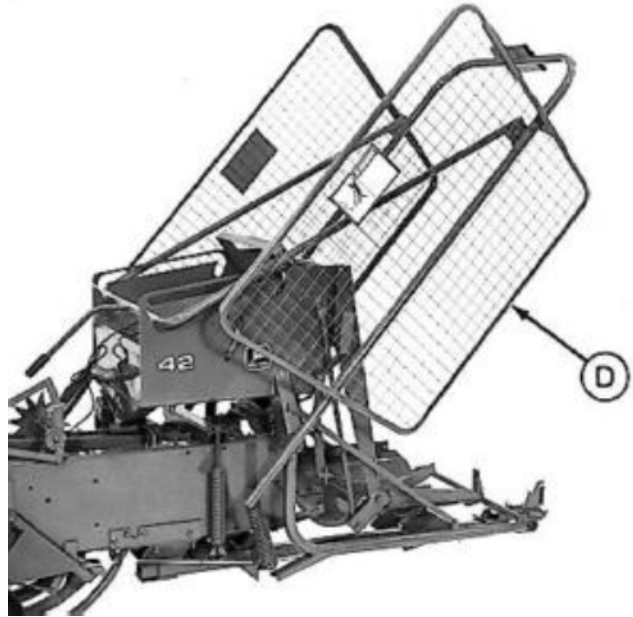

Servicing Position



CAUTION: To Prevent bodily injury, disengage PTO, stop tractor engine, and wait for all moving parts to stop before raising the side screens.

- Do not trip bale ejector with the side screens raised.
- Insure the lockout linkage is in working condition.

The side screens (D) provide protection from the throwing pan when the bale ejector is operational. The side screens can be raised to allow the servicing of the bale ejector, or access to the wagon hitch.

NOTE: Lockout lever (C) in locked position prevents the trip lever from tripping the bale ejector.

1. To raise the side screens, for servicing the bale ejector, lift up and forward on handle (A). Handle will trip linkage (B), as it moves forward, causing the lockout lever (C) to move into locked position.
2. To lower the screens, for operating or testing the bale ejector, lift up and rearward on handle.
3. Push the lockout lever rearward into operating position.

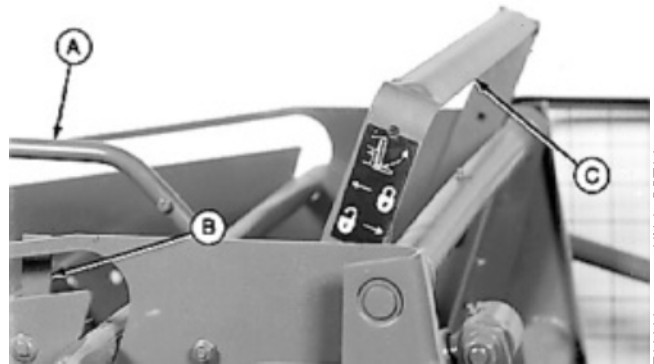

Lockout Lever—Operating Position

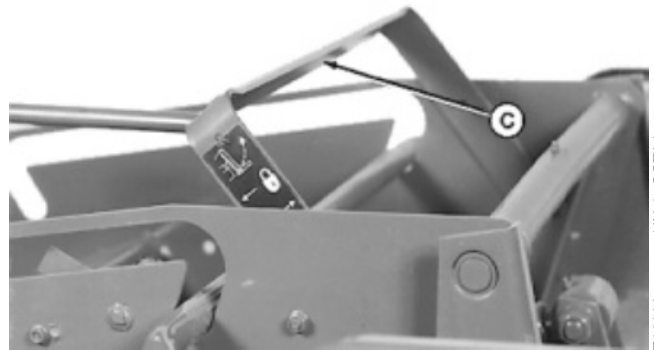

Lockout Lever—Locked Position

A—Handle
B—Linkage

C—Lockout Lever
D—Side Screens

EX.1584,1010,B -19-25MAR96

SPECIFICATIONS

- Bale (Cross Section) 366 mm x 457 mm (14-in. x 18-in.)
- Length (Approximately) 686 mm to 965 mm (27-in. to 38-in.)
- Bale Weight (Varies with condition of hay) 36 kg (80 lbs) maximum
- Weight of Ejector (With wagon hitch, less oil):
(42) (Approximately) 272 kg (600 lbs)
- Source of Power Hydraulic pump, belt driven from baler flywheel
- Hydraulic System Capacity:
(42) 32.2 L (8.5 U.S. gal)
- Hydraulic System Open Center
- Baler Works with John Deere 328, 338, 327, 336, 337, 346, 347 and 348 Balers only
- Capacity Equal to Baler

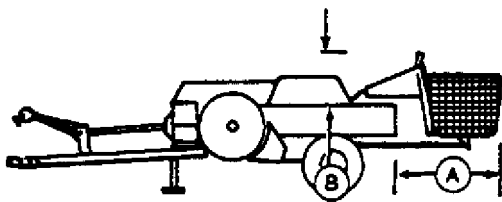

E24202 -UN-08MAY89

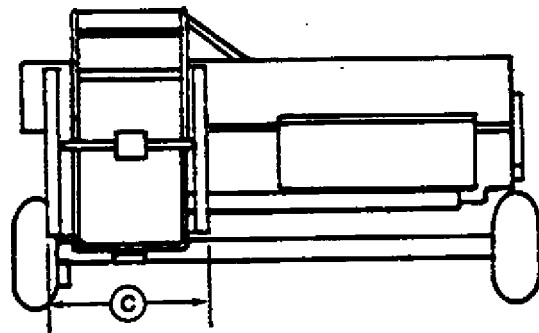

E24203 -UN-08MAY89

- A—Length (beyond end of bale case) (Approximately) 1727 mm (68-in.)
- B—Height (above bale case top):
(42) (Approximately) 787 mm (31-in.)
- C—Width (Approximately) 1211 mm (43-1/2 in.)

EX.1584,1015,A -19-02MAR95