

# **9400, 9500, and 9600 Combines Repairs**

**John Deere Harvester Works  
TM1401 (28JUL97)**

LITHO IN U.S.A.  
ENGLISH

# Introduction

## FOREWORD

This manual is written for an experienced technician. Essential tools required in performing certain service work are identified in this manual and are recommended for use.

Live with safety: Read the safety messages in the introduction of this manual and the cautions presented throughout the text of the manual.



This is the safety-alert symbol. When you see this symbol on the machine or in this manual, be alert to the potential for personal injury.

Technical manuals are divided in two parts: repair and operation and tests. Repair sections tell how to repair the components. Operation and tests sections help you identify the majority of routine failures quickly.

Information is organized in groups for the various components requiring service instruction. At the beginning of each group are summary listings of all applicable essential tools, service equipment and tools, other materials needed to do the job, service parts kits, specifications, wear tolerances, and torque values.

Technical Manuals are concise guides for specific machines. They are on-the-job guides containing only the vital information needed for diagnosis, analysis, testing, and repair.

Fundamental service information is available from other sources covering basic theory of operation, fundamentals of troubleshooting, general maintenance, and basic type of failures and their causes.

# Contents

## SECTION 10—GENERAL

- Group 05—Safety
- Group 10—Identification Number Location
- Group 15—Specifications
- Group 20—Tune Up and Adjustment
- Group 25—Fuels and Lubricants

## SECTION 20—ENGINE

- Group 05—Remove and Install Engine
- Group 10—Cooling System
- Group 15—Lower Engine Repair

## SECTION 30—FUEL AND AIR REPAIR

- Group 05—Air Intake System
- Group 10—Diesel Fuel System

## SECTION 40—ELECTRICAL SYSTEM

- Group 05—Components
- Group 10—Bulbs and Switches
- Group 15—Batteries
- Group 20—Harness and Connector Repair
- Group 25—Gauges and Monitors
- Group 30—Wiper and Radio
- Group 35—Alternator
- Group 40—Starting Motor
- Group 45—Electrical Engine Control

## SECTION 50—POWER TRAIN REPAIR

- Group 05—Transmission and Differential
- Group 10—Ring and Pinion Final Drive
- Group 15—Planetary Final Drive
- Group 20—Hydrostatic System
- Group 25—Cam Lobe Motor
- Group 30—Tires and Wheels

## SECTION 60—Power Steering and Brakes

- Group 05—Steering
- Group 10—Brakes

## SECTION 70—HYDRAULIC REPAIR

- Group 05—Hydraulic Reservoir
- Group 10—Hydraulic Pumps
- Group 15—Hydraulic Valves

- Group 20—Hydraulic Cylinders
- Group 25—Motors
- Group 30—Accumulator
- Group 35—Reel/Belt Pickup Pump Drive

## SECTION 80—SEPARATOR SHELL

- Group 05—Gull Wing Doors

## SECTION 90—OPERATOR STATION REPAIR

- Group 05—Air Conditioning System (R-12)—Type A
- Group 10—Air Conditioning System (R134A)—Type B
- Group 15—System Components
- Group 20—Cab

## SECTION 110—FEEDER HOUSE REPAIR

- Group 05—Feeder House/Conveyor
- Group 10—Feeder House Conveyor Drum
- Group 15—Conveyor Shaft and Slip Clutch
- Group 20—Feeder House Drives and Reverser Gear Case
- Group 25—CONTOUR MASTER Platform Driveshafts
- Group 30—CONTOUR MASTER Tilt Cylinder
- Group 35—CONTOUR MASTER Tilt Frame
- Group 40—CONTOUR MASTER Feeder House

## SECTION 120—SEPARATOR

- Group 05—Separator Repair
- Group 10—Cylinder Drives
- Group 15—Straw Walkers and Crankshafts
- Group 20—Straw Chopper, Straw Spreader and Chaff Spreader
- Group 25—Shoe Supply Augers, Cleaning Fan and Chaffer and Sieve Frame
- Group 30—Tailings Elevator and Augers
- Group 35—Primary Countershaft Gearcase
- Group 40—Header Electromagnetic Clutch

Continued on next page

*All information, illustrations and specifications in this manual are based on the latest information available at the time of publication. The right is reserved to make changes at any time without notice.*

TM1401-19-28JUL97

COPYRIGHT© 1997  
DEERE & COMPANY  
Moline, Illinois  
All rights reserved

A John Deere ILLUSTRATION™ Manual  
Previous Editions  
Copyright 1994, 1992, 1989, 1988 Deere & Company

**SECTION 130—GRAIN TANK AND UNLOADING  
SYSTEM REPAIR**

- Group 05—Grain Tank Cross Augers
- Group 10—Unloading Auger System Drives
- Group 15—Vertical Unloading Auger and Lower Gearcase
- Group 20—Horizontal Unloading Auger and Gearcase
- Group 25—Upper Clean Grain Elevator
- Group 30—Grain Tank and Extensions
- Group 35—Clean Grain Elevator and Loading Auger Gear Case

**SECTION 140—ENGINE GEARCASE AND  
CONTROL VALVE REPAIR**

- Group 05—Engine Gearcase and Valve

**SECTION 160—DIAL-A-MATIC HEADER HEIGHT  
CONTROL**

- Group 05—Dial-A-Matic Header Height Control

**Index**

# Section 10 GENERAL

10

## Contents

	Page		Page
<b>Group 05—Safety</b> . . . . .	10-05-1		
<b>Group 10—Identification Number Location</b>			
Combine Identification Number . . . . .	10-10-1	Engine Coolant . . . . .	10-25-3
Transmission . . . . .	10-10-1	Liquid Coolant Conditioner . . . . .	10-25-3
Engine Serial Number for 9400 Combines . . . . .	10-10-1	Engine Oil . . . . .	10-25-4
Hydrostatic Drive Unit Pump . . . . .	10-10-2	Greases . . . . .	10-25-7
Hydrostatic Drive Unit Motor . . . . .	10-10-2	Lubricant Storage . . . . .	10-25-7
Cam Lobe 4-Wheel Drive Motor . . . . .	10-10-2	Alternative and Synthetic Lubricants . . . . .	10-25-8
Engine Gearcase . . . . .	10-10-2	Filter Part Numbers . . . . .	10-25-8
Cab . . . . .	10-10-3		
<b>Group 15—Specifications</b>			
Specifications—9400 Combines . . . . .	10-15-1		
Operating Speeds—9400 Combines . . . . .	10-15-3		
Ground Speeds (Separator Full Load) . . . . .	10-15-4		
Specifications—9500 Combines . . . . .	10-15-5		
Operating Speeds—9500 Combines . . . . .	10-15-7		
Ground Speeds . . . . .	10-15-8		
Specifications—9600 Combines . . . . .	10-15-9		
Operating Speeds—9600 Combines . . . . .	10-15-11		
Dimensions . . . . .	10-15-14		
Metric Bolt and Cap Screw Torque			
Values . . . . .	10-15-15		
Unified Inch Bolt and Cap Screw Torque			
Values . . . . .	10-15-16		
O-Ring Boss Fitting Torque Chart . . . . .	10-15-17		
Flat Face O-Ring Seal Fitting Torque			
Chart . . . . .	10-15-18		
SAE Four Bolt Flange Fitting Torque			
Chart . . . . .	10-15-19		
Prevent Hydraulic System Contamination . . . . .	10-15-20		
Check Oil Lines and Fittings . . . . .	10-15-21		
<b>Group 20—Tune Up and Adjustment</b>			
Tune-Up and Adjustment . . . . .	10-20-1		
Care and Maintenance of Belts . . . . .	10-20-2		
Defective Belts . . . . .	10-20-3		
Right-Hand Drives and Part Numbers . . . . .	10-20-5		
Left-Hand Drives and Part Numbers . . . . .	10-20-7		
<b>Group 25—Fuels and Lubricants</b>			
Diesel Fuel . . . . .	10-25-1		
Fuel Storage . . . . .	10-25-2		

## RECOGNIZE SAFETY INFORMATION

This is the safety-alert symbol. When you see this symbol on your machine or in this manual, be alert to the potential for personal injury.

Follow recommended precautions and safe operating practices.

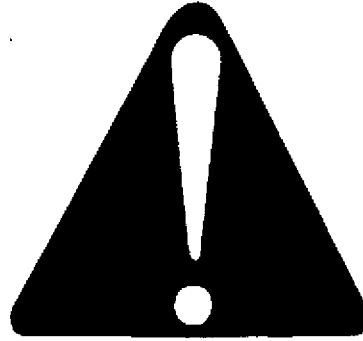

DX,ALERT -19-03MAR93

10  
05  
1  
T81389 -UN-07DEC88

## UNDERSTAND SIGNAL WORDS

A signal word—DANGER, WARNING, or CAUTION—is used with the safety-alert symbol. DANGER identifies the most serious hazards.

DANGER or WARNING safety signs are located near specific hazards. General precautions are listed on CAUTION safety signs. CAUTION also calls attention to safety messages in this manual.



DX,SIGNAL -19-03MAR93

TS187 -19-30SEP88

## HANDLE FLUIDS SAFELY—AVOID FIRES

When you work around fuel, do not smoke or work near heaters or other fire hazards.

Store flammable fluids away from fire hazards. Do not incinerate or puncture pressurized containers.

Make sure machine is clean of trash, grease, and debris.

Do not store oily rags; they can ignite and burn spontaneously.



DX,FLAME -19-04JUN90

TS227 -UN-23AUG88

## SPECIFICATIONS

Item	Measurement	Specification
Engine:		
6359 (9400 Combine)	Approximate Weight	533 kg (1175 lb)
6068 (9400 Combine)	Approximate Weight	602 kg (1324 lb)
6076 (9500 and 9600 Combines)	Approximate Weight	816 kg (1800 lb)
Engine-to-Bell Housing Cap Screws	Torque	340 N·m (250 lb-ft)
Engine Mount Cap Screw	Torque	80 N·m (60 lb-ft)
Engine Crankcase:		
9400 Combine (6359A)	Capacity	14 L (14-1/2 qt)
(6068H)	Capacity	18.9 L (20 qt)
9500 and 9600 Combines	Capacity	25 L (26-1/2 qt)
Cooling System (With Heater):		
9400, 9500 and 9600 Combines	Capacity	36 L (38 qt)
9600 Corn Combine	Capacity	40 L (42 qt)

HX1401,2005,C -19-05DEC96

## REMOVE ENGINE

1. At both batteries in the engine compartment, disconnect both negative (ground) terminal clamps (A) first. Lift the protective covers and remove both positive terminal clamps (B).

- A—Negative Clamps
- B—Positive Clamps
- C—Batteries

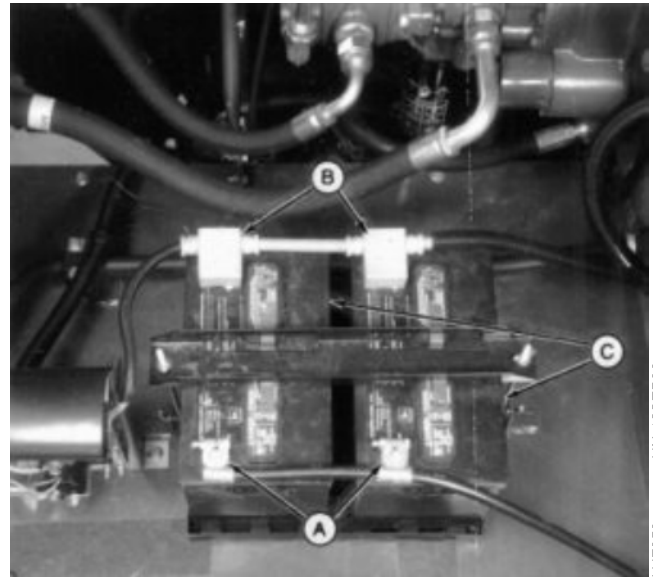

-JUN-12SEP96  
H47959

HX,1401,2005,AA-19-16SEP96

## Remove and Install Engine/Remove Engine

**NOTE:** The following steps 2 through 5 reflect removal for combines: 9400 ( -640100), 9500 ( -640200), 9600 ( -640300).

2. Open hinged access above engine.
3. Remove cap screws (A, B and D) to remove channel (C).
4. Remove cap screws (E, F, L and N) and pin (J) to remove cover sheet (K).
5. Remove wing screws (I) and pin (G) to remove fan guard door (H).

A—Cap Screw (2 used)  
 B—Cap Screw (2 used)  
 C—Channel  
 D—Cap Screw (2 used)  
 E—Cap Screw (2 used)  
 F—Cap Screw (2 used)  
 G—Pin  
 H—Fan Guard Door  
 I—Wing Screw (2 used)  
 J—Pin  
 K—Cover Sheet  
 L—Cap Screw (2 used)  
 M—Channel  
 N—Cap Screw

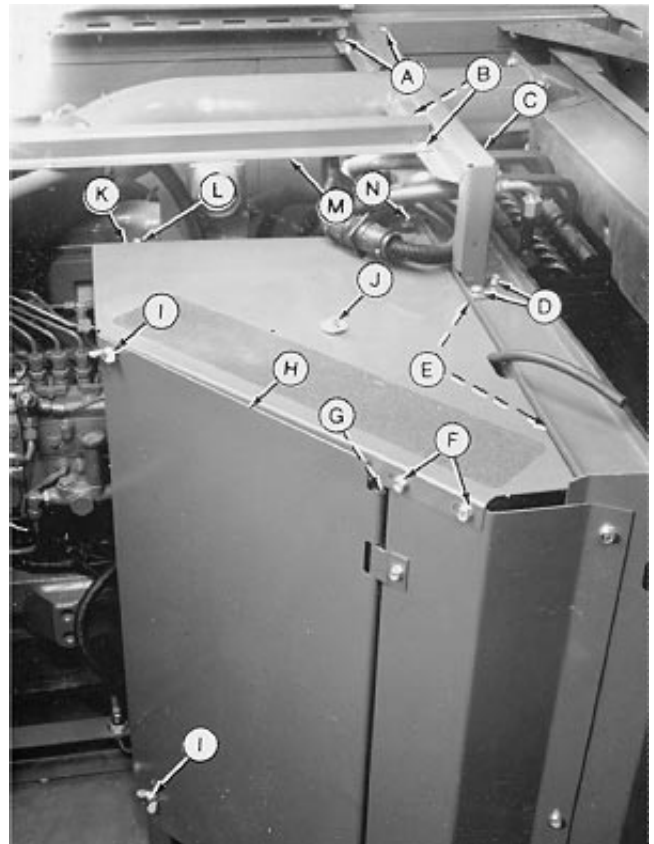

HX,1401,2005,A -19-28AUG96

20  
05  
3

-UN-05JUN89  
H40455

**NOTE:** The following steps 6 through 9 reflect removal for combines: 9400 (640101- ), 9500 (640201- ), 9600 (640301- ).

6. Open hinged access above engine.
7. Remove cap screws (A) and spacers (L).
8. Remove cap screws (B, C, I and K) and lock pin (G) to remove cover sheet (H).
9. Remove wing screws (F) and hinge pin (D) to remove fan guard door (E).

A—Cap Screw (2 Used)  
 B—Cap Screw (2 Used)  
 C—Cap Screw (2 Used)  
 D—Hinge Pin  
 E—Fan Guard Door  
 F—Wing Screw (2 Used)  
 G—Lock Pin  
 H—Cover Sheet  
 I—Cap Screw (2 Used)  
 J—Channel  
 K—Cap Screw and Clamp  
 L—Spacer (2 Used)

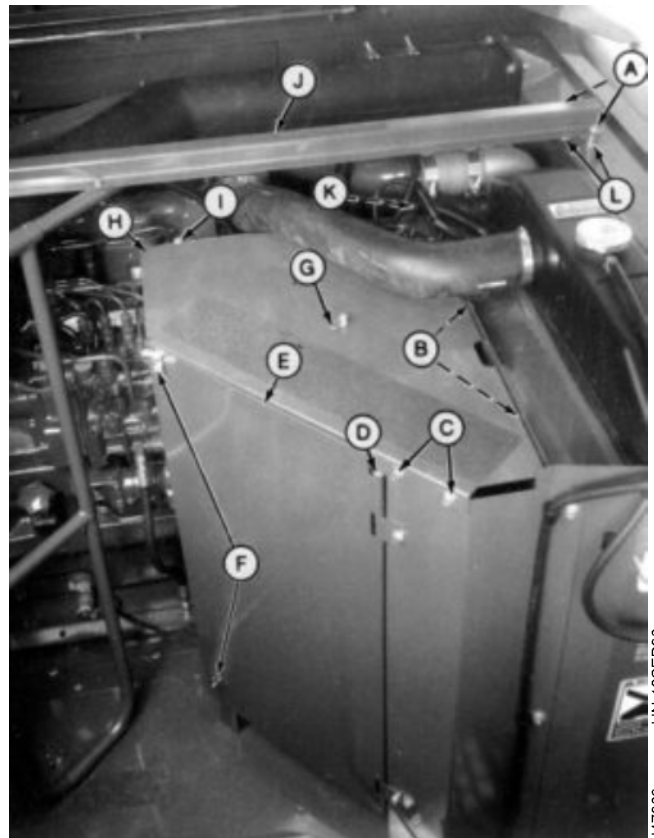

1401,DV469 -19-27SEP96

-UN-12SEP96  
H47960



## Remove and Install Engine/Remove Engine

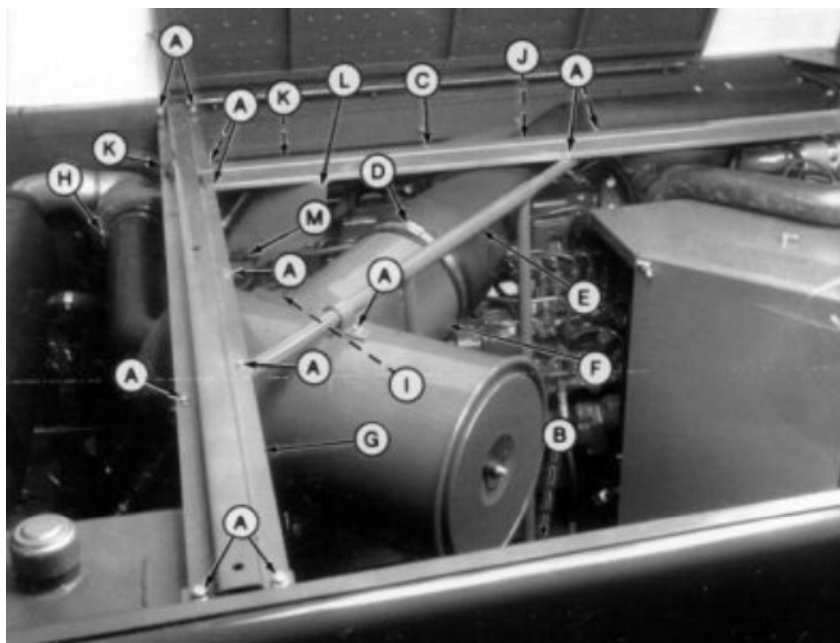

A—Cap Screws (12 used)

B—Wing Screw

C—Channel

D—Clamp

E—Brace with Ladder

F—Air Intake Tube

G—Channel

H—Clamp

I—Clamp

J—Cap Screw

K—Cap Screw (2 Used)

L—Harness Shield

M—Sensor Connector

*9500 and 9600 Combines Shown*

10. Remove cap screws (A and K), wing screw (B) (at ladder base) and air inlet duct cap screw (J) to remove channels (C and G), harness shield (L) and brace with ladder (E).

*NOTE: Bend harness retainers, located on the underside of the channels, slightly to allow harnesses to be removed from channel.*

11. Disconnect air cleaner plugged sensor connector (M).

12. Remove clamps (D, H and I) to remove air cleaner intake tube (F) and air cleaner.

HX,1401,2005,BB-19-28AUG96

Remove and Install Engine/Remove Engine

13. Remove four cap screws (A) from air cleaner intake tube (C).

14. (9500 and 9600 Only) Remove clamp (B) from intercooler tubes (D).

- A—Cap Screws (4 Used)
- B—Clamps
- C—Intake Tube
- D—Intercooler Tubes

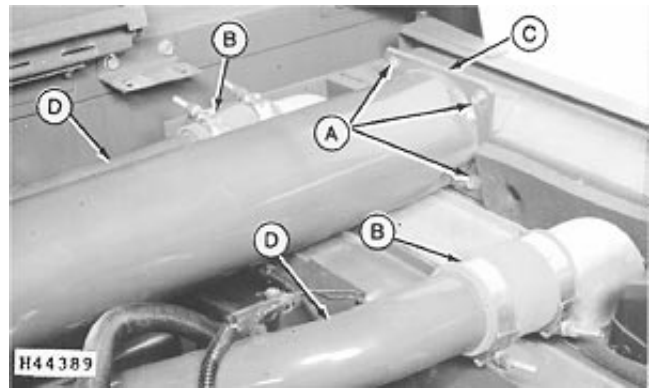

9500 and 9600 Combine Shown

HX,1401,2005,B -19-27SEP96



**CAUTION: Coolant may be hot. Wait until radiator is cool to the touch before draining coolant.**

15. Drain cooling system and remove radiator hoses. (See procedure in Group 10.)

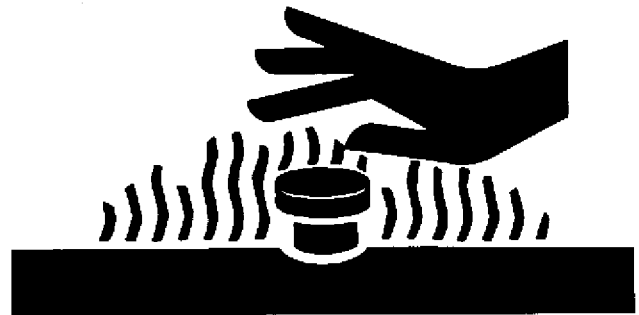

HX,1401,2005,C -19-28AUG96

**NOTE:** The following steps 16 through 20 reflect removal for combines: 9400 ( —640100), 9500 ( —640200), 9600 ( —640300).

16. Disconnect wiring leads (A, B, F, G, and I-K).
17. Remove air conditioner compressor belt (D) and fan belt (L).
18. (9400 and 9500 Only) Remove fan belt drive (E) and fan (C).
19. (9600 Only) Remove cap screws (N) from drive disk (O).
20. Remove fuel line (H) and return line (M). Put caps or covers on fittings to keep dirt from entering fuel system.

- A—Wiring Lead-to-Hydraulic Reservoir Sending Unit
- B—Main Wiring Harness Connector
- C—Fan
- D—Belt
- E—Fan Belt Drive
- F—Ground Wire
- G—Wiring Harness Lead-to-Alternator
- H—Fuel Line
- I—Wiring Harness Lead-to-Tachometer Sender Injection Pump
- J—Wiring Harness Lead-to-Governor (2 used) Injection Pump
- K—Wiring Harness Lead-to-Fuel Pump Injection Pump
- L—Fan Belt
- M—Fuel Return Line
- N—Cap Screws
- O—Drive Disk

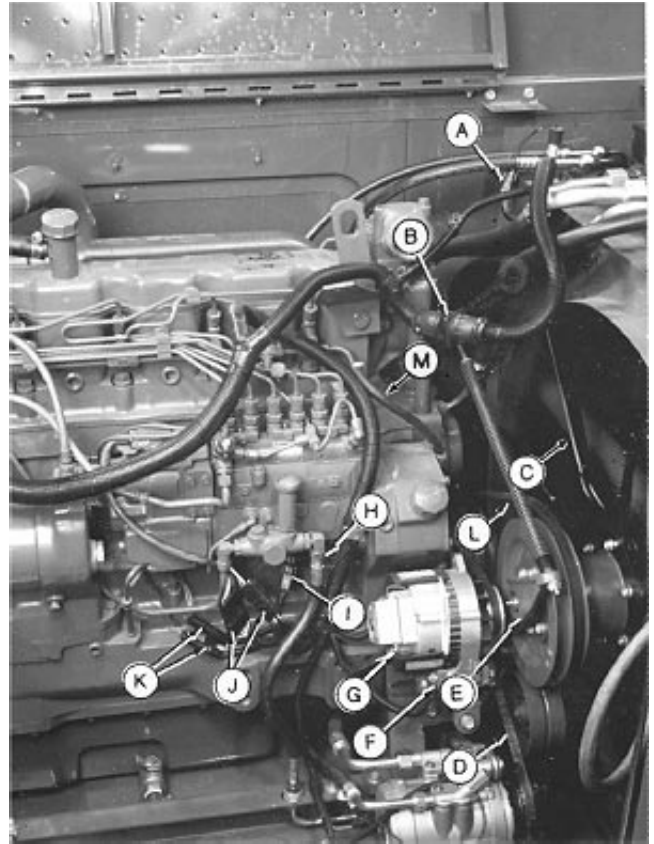

9500 Combine Shown

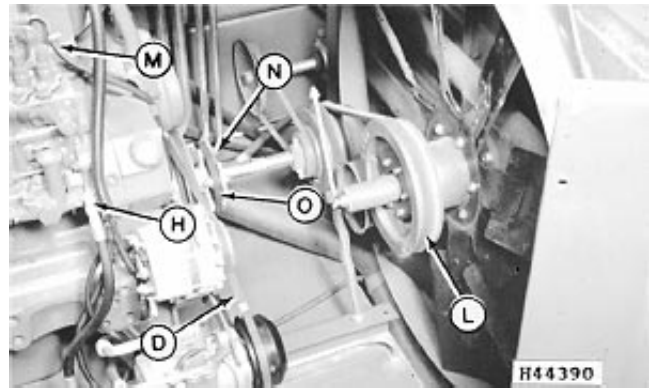

9600 Combine Shown

HX1401,2005,D -19-28AUG96

20  
05  
6

H44721 -UN-01JUL92

H44390 -UN-21MAY92

**NOTE:** The following steps 21 through 25 reflect removal for combines: 9400 ( —650100), 9500 ( —650200), 9600 ( —650300).

21. Disconnect wiring leads (A, B, F, G and I-K).
22. Remove air conditioner compressor belt (D) and fan belt (L).
23. (9400 and 9500 Only) Remove fan belt drive (E) and fan (C).
24. (9600 Only) Remove cap screws (N) from drive disk (O).
25. Remove fuel line (H) and return line (M). Put caps or covers on fittings to keep dirt from entering fuel system.

- A—Wiring Lead to Hydraulic Reservoir Sending Unit
- B—Main Wiring Harness Connector
- C—Fan
- D—Belt
- E—Fan Belt Drive
- F—Ground Wire
- G—Wiring Harness Lead to Alternator
- H—Fuel Line
- I—Wiring Harness Lead-to-Tachometer Sender Injection Pump
- J—Wiring Harness Lead-to-Governor (2 used)-Injection Pump
- K—Wiring Harness Lead-to-Fuel Pump-Injection Pump
- L—Fan Belt
- M—Fuel Return Line
- N—Cap Screws
- O—Drive Disk

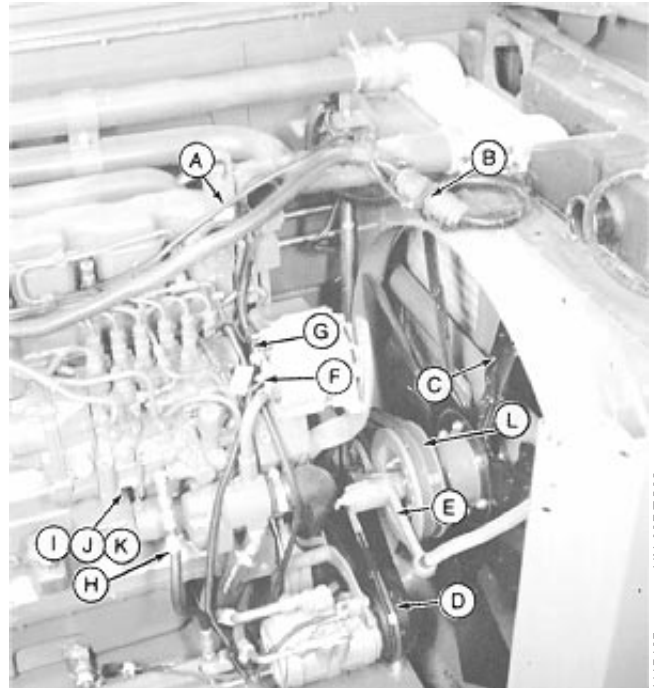

9500 Combine Shown

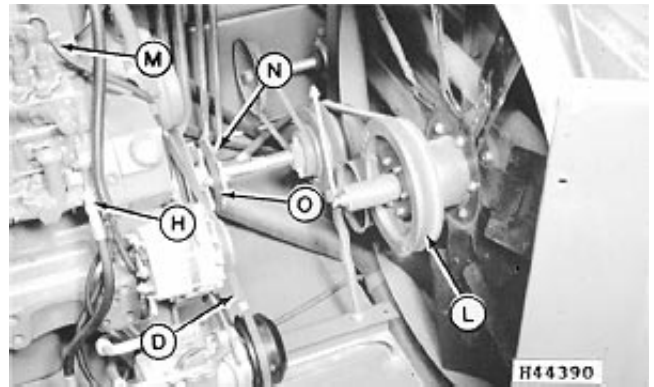

9600 Combine Shown

HX1401,2005,E -19-27SEP96

20  
05  
7

H45465 -JUN-09DEC92

H44390 -JUN-21MAY92

**NOTE:** The following steps 26 through 30 reflect removal for combines: 9400 (650101— ), 9500 (650201— ), 9600 (650301— ).

26. Disconnect wiring leads (A, B, F, G and I-K). (Combines with Nippondenso Fuel Inj; Disconnect wiring lead to injection pump governor (J)).
27. Remove air conditioner compressor belt (D) and fan belt (L).
28. (9400 and 9500 Only) Remove fan belt drive (E) and fan (C).
29. (9600 Only) Remove cap screws (N) from drive disk (O).
30. Remove fuel line (H) and return line (M). Put caps or covers on fittings to keep dirt from entering fuel system.

- A—Wiring Lead-to-Hydraulic Reservoir Sending Unit
- B—Main Wiring Harness Connector
- C—Fan
- D—Belt
- E—Fan Belt Drive
- F—Ground Wire
- G—Wiring Harness Lead-to-Alternator
- H—Fuel Line
- I—Wiring Harness Lead-to-Tachometer Sender-Injection Pump
- J—Wiring Harness Lead-to-Governor (2 used)-Injection Pump
- K—Wiring Harness Lead-to-Fuel Pump-Injection Pump
- L—Fan Belt
- M—Fuel Return Line
- N—Cap Screws
- O—Drive Disk

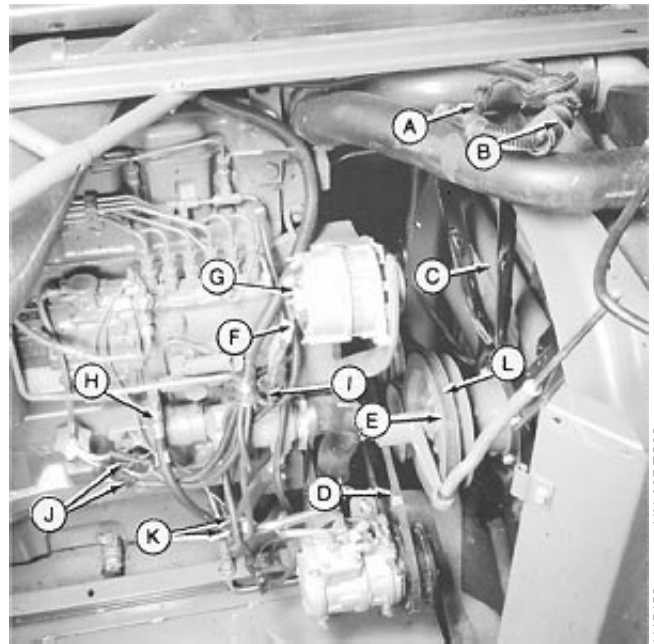

9500 W/Nippondenso Fuel Inj.

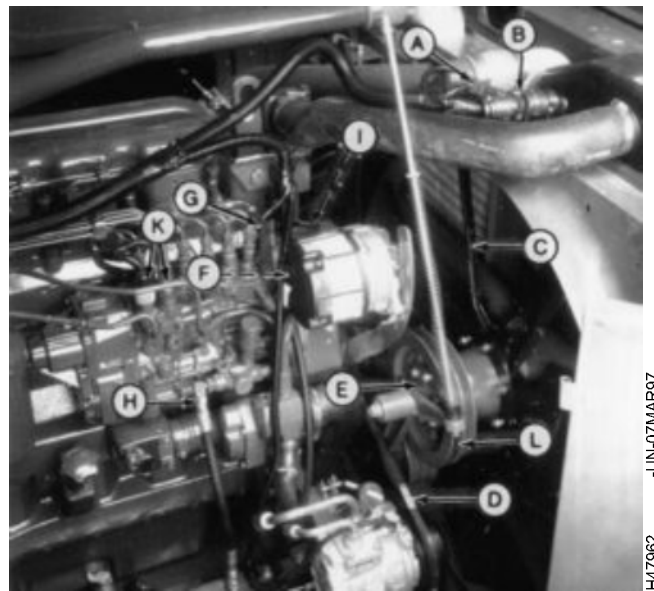

9500 W/Bosch Fuel Inj.

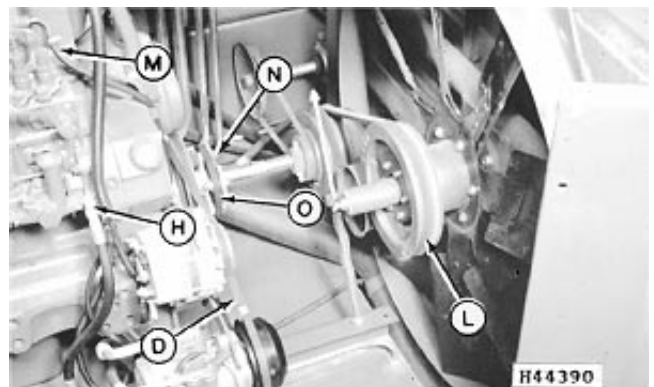

9600 Combine Shown

20  
05  
8

-JUN-09DEC92  
H46452

-JUN-07MAR97  
H47962

-JUN-21MAY92  
H44390

Remove and Install Engine/Remove Engine

- 31. Disconnect wiring connector (A) from engine temperature switch.
- 32. Remove cap screws (B) from exhaust manifold.
- 33. Disconnect sending unit wiring lead (C).

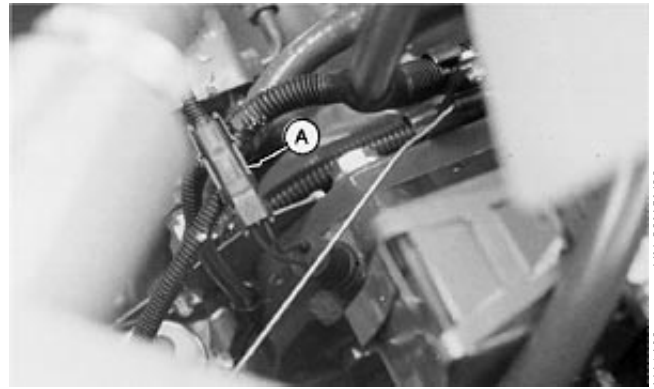

9400 Combine

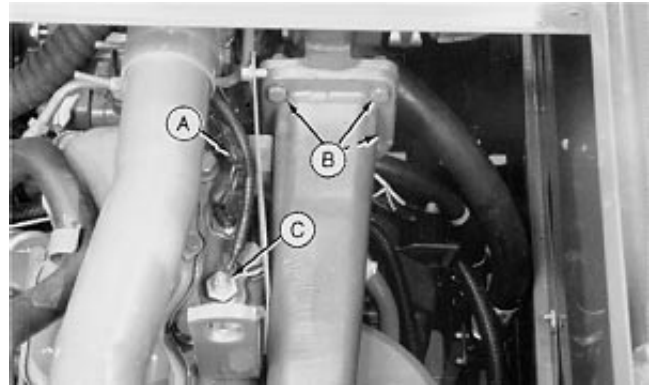

9500 and 9600 Combines

HX,1401,2005,F -19-28AUG96

- 34. From inside grain tank remove six cap screws (A) to remove engine access panel (B).

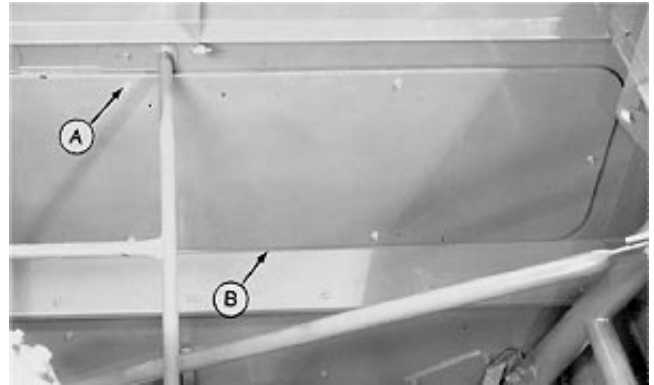

HX,1401,2005,G -19-28AUG96

- 35. (9400 Only) Disconnect leads (A) from throttle control.

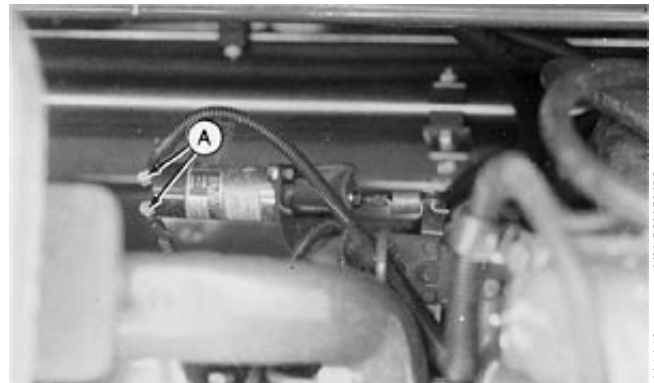

9400 Combine

HX,1401,2005,H -19-28AUG96

H-41409 -JUN-28NOV89

H-40468 -JUN-05JUN89

H-40469 -JUN-05JUN89

H-41410 -JUN-28NOV89

9520

36. Disconnect fuel line (A) from fuel transfer pump.

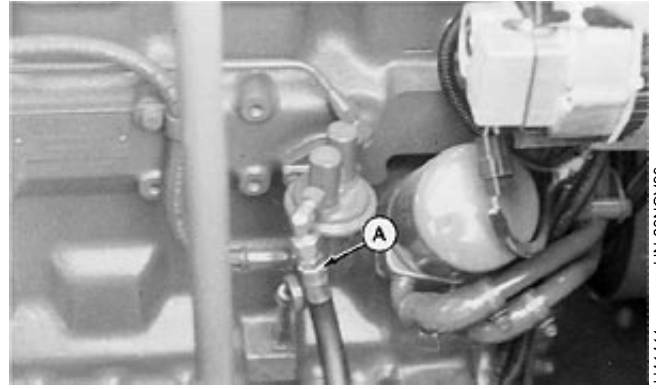

9400 Combine

H-41411  
-UN-28NOV89

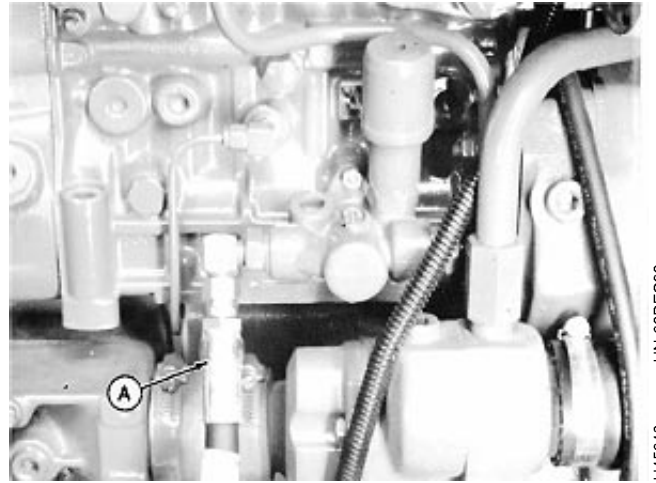

9500 Combine

H45046  
-UN-02DEC92

HX,1401,2005,I -19-28AUG96

37. (9600) Disconnect heater hoses (A and B) and turbocharger tube (E).

- A—Heater Hose
- B—Heater Hose
- C—Block Heater
- D—Block Drain
- E—Turbocharger Tube

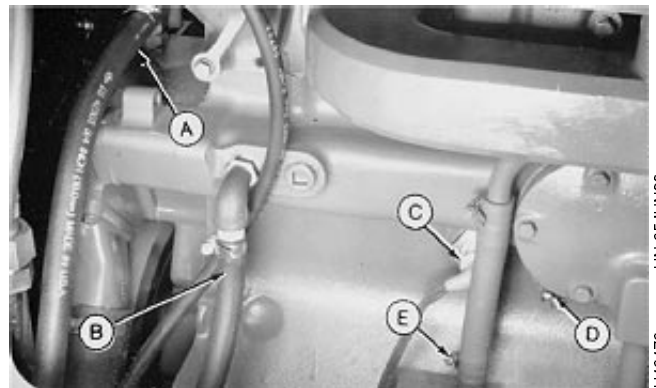

9600 Combine

H40470  
-UN-05JUN89

HX,1401,2005,J -19-27SEP96

20  
05  
10

38. (9500) Disconnect heater hose (A) and turbocharger return oil line (D).

- A—Heater Hose
- B—Block Heater
- C—Block Drain
- D—Turbocharger Return Oil Line
- E—Turbocharger Tube Mount Clamp

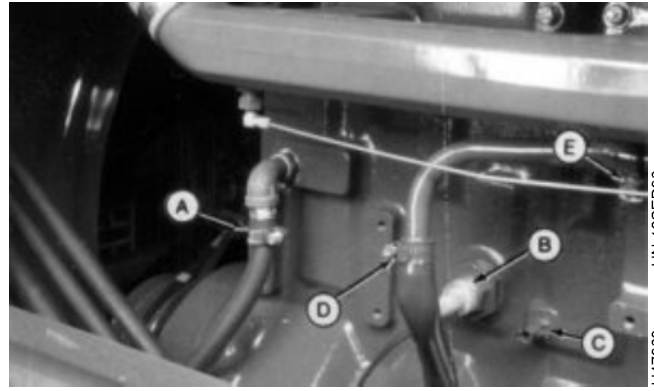

9500 Combine

1401,DV699 -19-27SEP96

H47963 -UN-12SEP96

20-05-11



39. Disconnect cold weather starting aid line (A).

40. Remove parts (B—G) from starting motor.

- A—Starting Aid Line
- B—Nut (2 used)
- C—Main Harness
- D—Plastic Cover
- E—Wiring Harness
- F—Battery Cable
- G—Terminal Nut

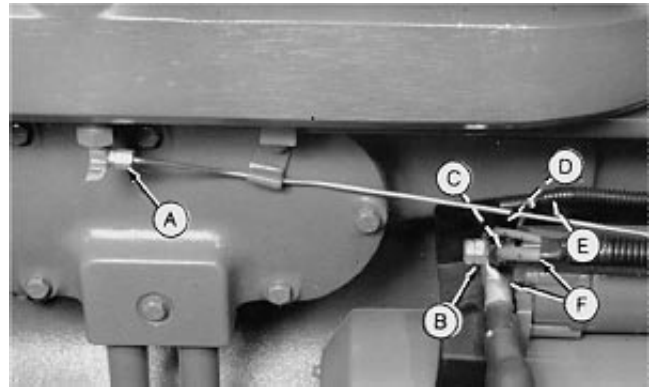

9600 Combine

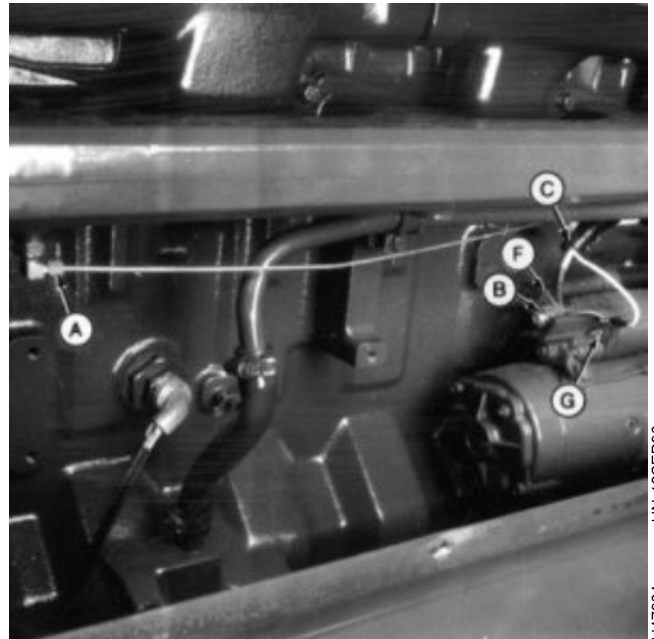

9500 Combine

HX,1401,2005,K -19-28AUG96

20  
05  
12

41. On lower surface of the turbocharger remove two cap screws (A) at return oil line (B) mount flange. Remove oil line.

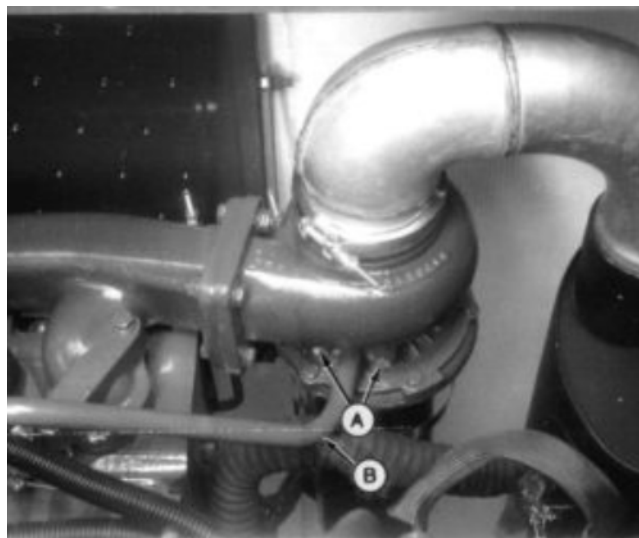

H-47965 -UN-12SEP96

1401,DV470 -19-28AUG96



**CAUTION:** The approximate weight of the 6359 engine is 533 kg (1175 lbs). The approximate weight of the 6068 engine is 602 kg (1324 lbs). The approximate weight of the 6076 engine is 816 kg (1800 lbs).

**IMPORTANT:** Use only a lifting sling, like the JDG-23 that has a spreader bar. Other types of lift slings could damage the cylinder head.

42. Install JDG-23 engine lifting sling (A). Take up slack in lift chains before removing engine mount cap screws.

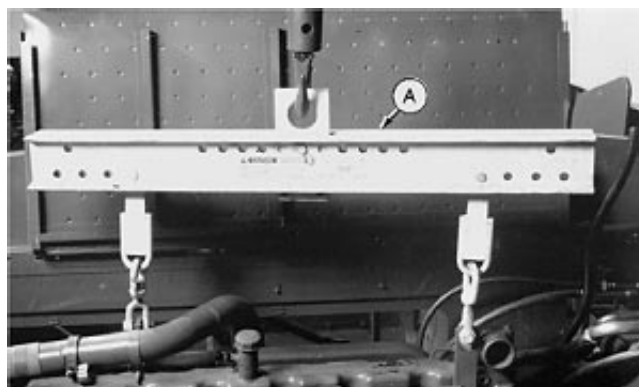

H-40533 -UN-05JUN89

HX1401,2005,G -19-28AUG96

Remove and Install Engine/Remove Engine

- 43. Remove front engine mount cap screws (A—C).
- 44. Remove front engine mount cap screws (A and B).
- 45. Remove cap screw(s) (C).

A—Cap Screw (2 used)  
B—Cap Screw (2 used)  
C—Cap Screw (quantity depends on mt instln)

20  
05  
14

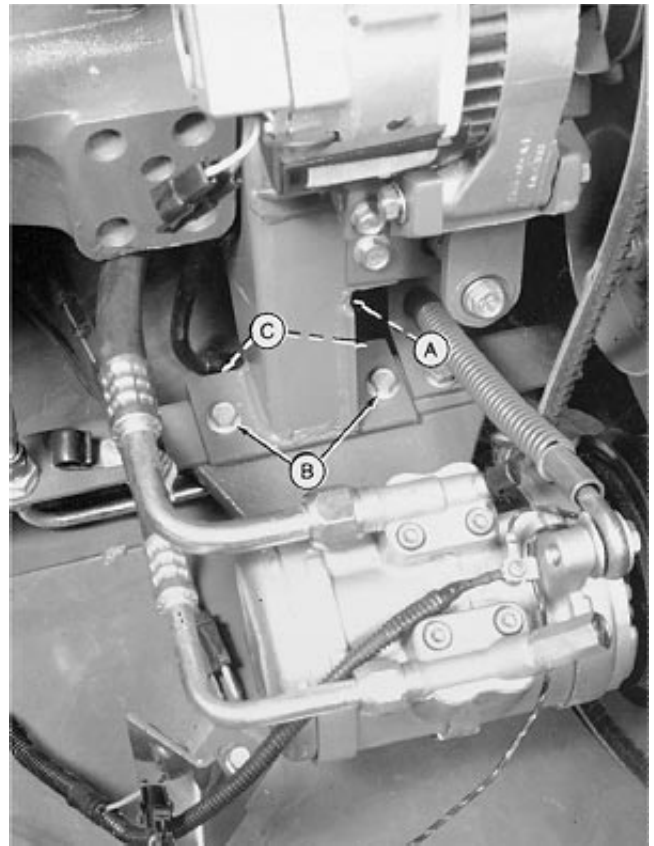

H40472  
-UN-05JUN89

9500( -640200) and 9600( -640300)

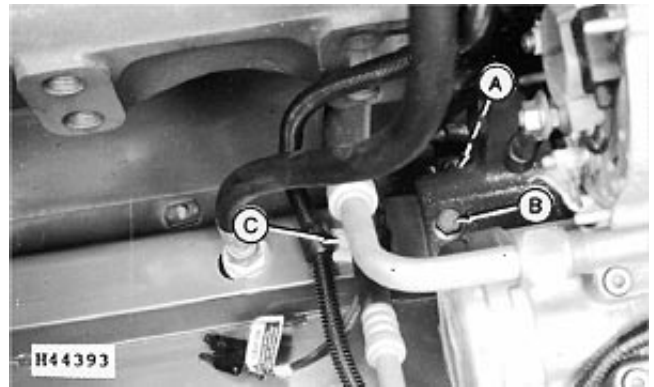

H44393  
-UN-21MAY92

Later Models\*



H47966  
-UN-12SEP96

Latest Models\*\*

\* = 9500(640201 - 655551), SH9500(645201 - 655531) and 9600(640301 - 655524)

\*\* = 9500/SH9500(655552- ) and 9600(655525- )

HX,1401,2005,M -19-05DEC96

**NOTE:** DO NOT disconnect refrigerant lines.

46. Remove electrical connections (A and B).

47. Remove cap screws (C and D), remove belt from pulley, and place air conditioner compressor on floor of engine compartment.

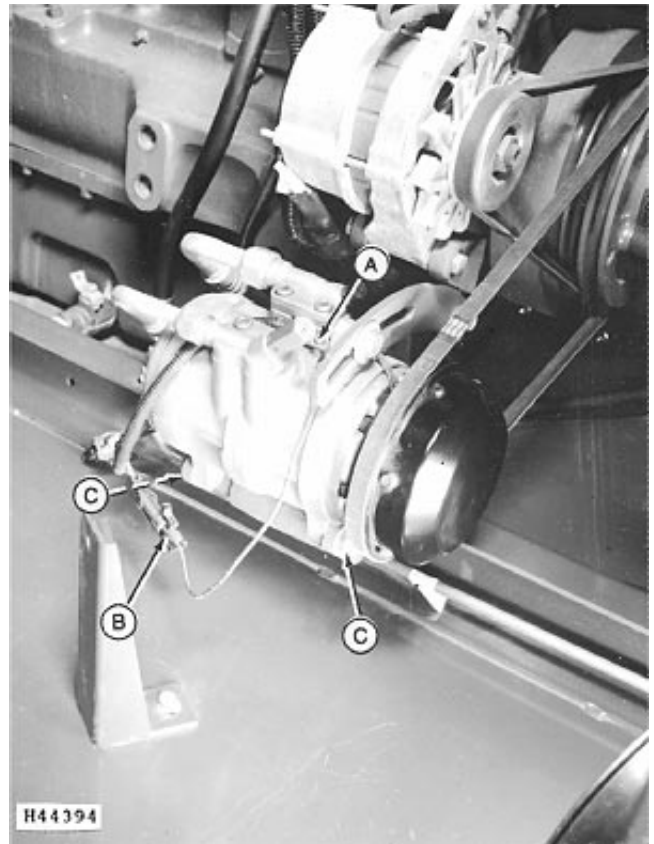

R-12 A/C Compressor Shown

- A—Electrical Connector
- B—Electrical Connector
- C—Cap Screw
- D—Cap Screw

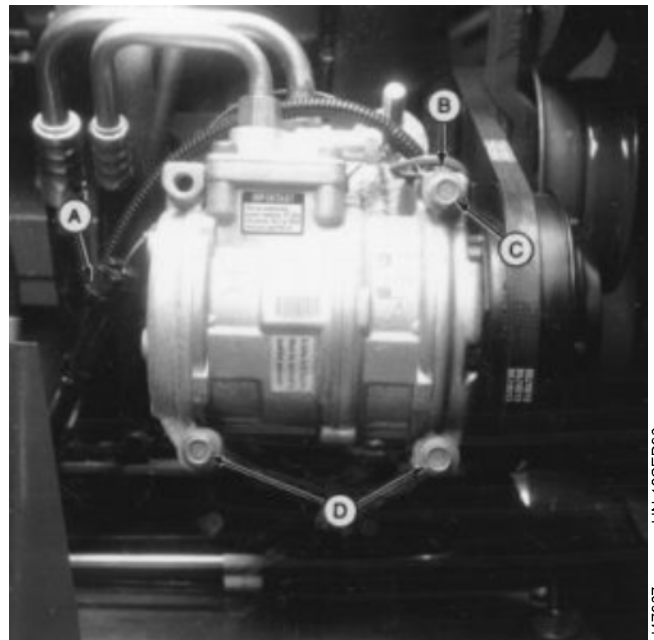

R-134a A/C Compressor Shown

48. Remove clamp (B) to remove breather hose (A).
49. Remove turbocharger oil line (C).
50. Drain engine oil. Approximate capacity is 14 L (14-1/2 qt) for 6359 engine, 19 L (20 qt) for 6068 engine on 9400 combine and 23.2 L (24-1/2 qt) on 9500 and 9600 combines.
51. Remove engine oil drain line (D) from shut-off valve.
52. Disconnect oil pressure sending switch connector (F).
53. Disconnect fuel injector pump connectors (I) (Bosch Fuel Injection - S/N 536794- ).
54. Remove rear mounting cap screws (E) on each side.
55. Remove bellhousing cap screws (H) and dust cover cap screws (G).

- A—Breather Hose
- B—Clamp
- C—Turbocharger Oil Line
- D—Oil Drain Line
- E—Cap Screw (4 used)
- F—Oil Pressure Sending Switch Connector
- G—Cap Screw (4 used)
- H—Cap Screw (4 used)
- I—Fuel Injector Pump Connectors (Bosch)

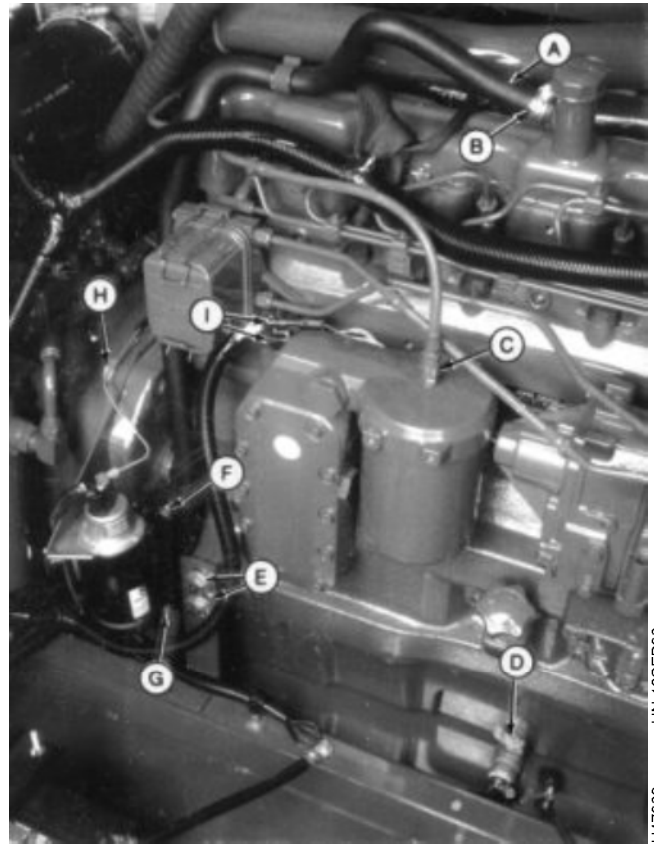

H47968 -JUN-12SEP96

HX1401,2005,H -19-27NOV96

**CAUTION:** Use extreme care when lifting and NEVER permit any part of the body to be positioned under a load being lifted or suspended.

56. Attach engine hoist fixture (A) to engine lift fittings. Carefully move engine away from bellhousing. Lift engine out of combine.
57. For 9400 combine, see CTM-4 or CTM-8 for engine repair; for 9500, 9600 and CTS combines, see CTM-6 or CTM-42 for engine repair.

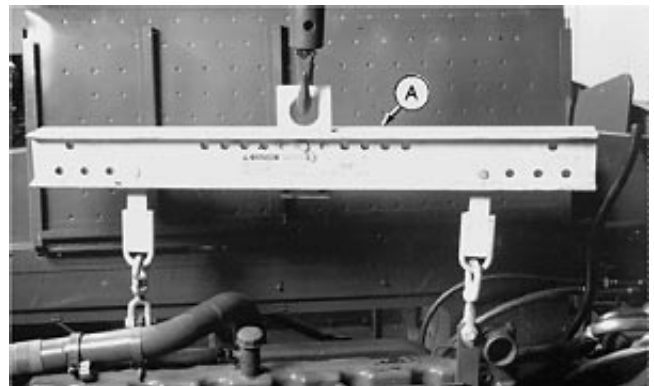

H40533 -JUN-05JUN89

HX1401,2005,I -19-05DEC96

**Thank you very much for your reading. Please Click Here. Then Get COMPLETE MANUAL. NO WAITING**



**NOTE:**

**If there is no response to click on the link above, please download the PDF document first and then click on it.**

## INSTALL ENGINE

**⚠ CAUTION:** Use extreme care when lifting engine and **NEVER** permit any part of the body to be positioned under a load being lifted or suspended.

1. Carefully lower engine to align with bellhousing.

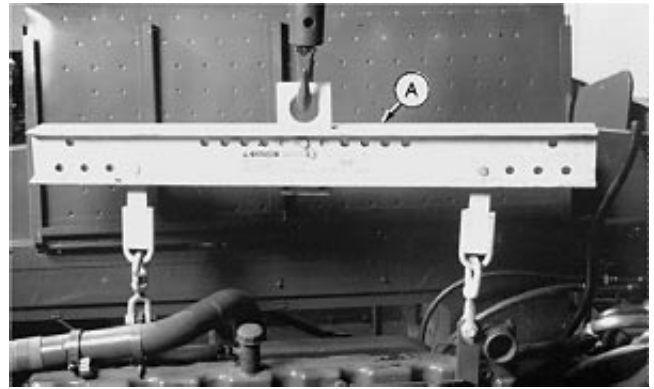

HX,1401,2005,AE-19-17DEC92

H-40533 -UN-05JUN89

20  
05  
17

20  
05  
18

2. Install bellhousing cap screws (H). Tighten to 340 N·m (250 lb-ft).
3. Install rear mounting cap screws (E) and tighten to 80 N·m (60 lb-ft).
4. Install dust cover cap screws (G).
5. Connect oil pressure sending switch connector (F).
6. (Bosch Fuel Inj - Eng S/N 536794- ) Connect fuel injector pump connectors (I).
7. Install engine oil drain line (D) to shut-off valve.
8. Install turbocharger oil line (C).
9. Install breather hose (A). Tighten clamp (B).

- A—Breather Hose
- B—Clamp
- C—Turbocharger Oil Line
- D—Oil Drain Line
- E—Cap Screw (4 used)
- F—Oil Pressure Sending Switch Connector
- G—Cap Screw (4 used)
- H—Cap Screw (4 used)
- I—Fuel Inj Pump Connectors  
(Bosch Fuel Inj-Eng S/N 536794- )

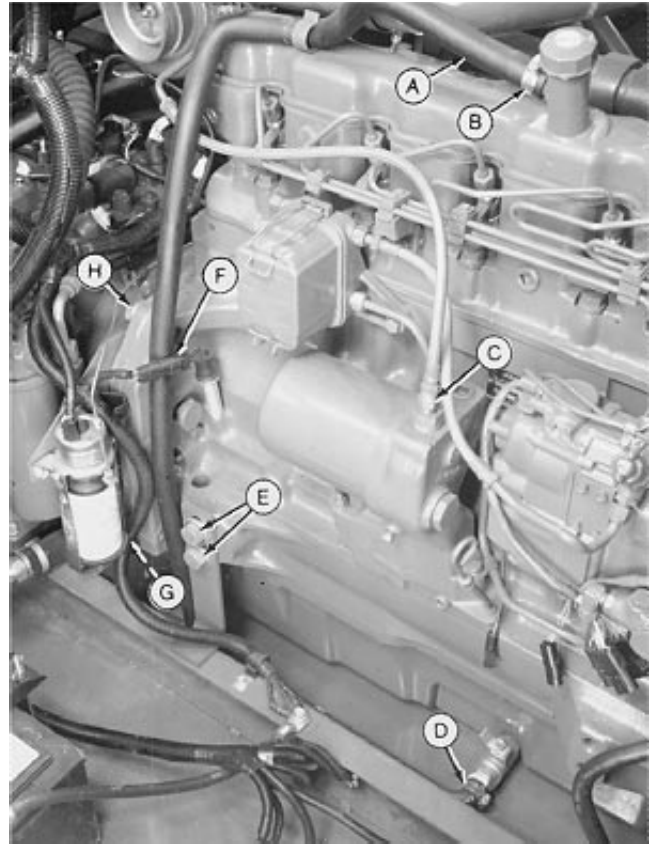

-JUN-05JUN89  
H40473

9400 Combine Shown

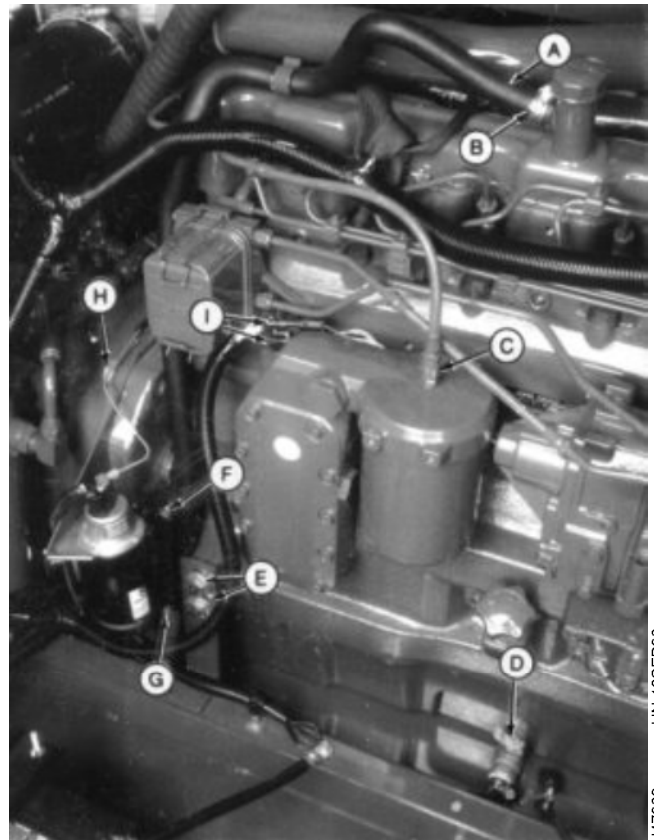

-JUN-12SEP96  
H47968

9500 and 9600 Combines Shown

HX1401,2005,J -19-05DEC96