

**30 AND 50
EXCAVATORS**

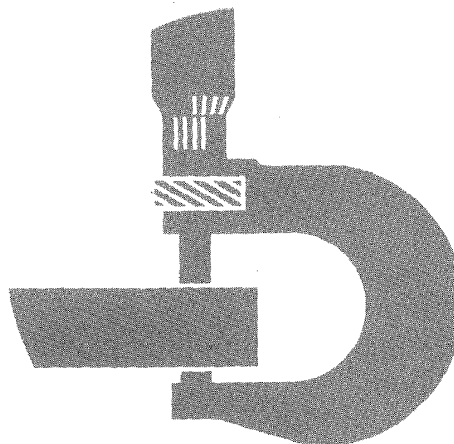

TECHNICAL MANUAL

30 AND 50 EXCAVATORS TECHNICAL MANUAL TM-1380 (DEC-86)

SECTION AND GROUP CONTENTS

SECTION I—GENERAL INFORMATION

- Group I—Introduction and Safety Information
- Group II—General Specifications
- Group III—Torque Values
- Group IV—Fuels and Lubricants
- Group V—Inspection Procedures

SECTION 01—TRACKS

- Group 0130—Track Systems

SECTION 02—AXLE AND SUSPENSION SYSTEMS (PROPEL)

- Group 0250—Axle Shafts, Bearings and Reduction Gears
- Group 0260—Hydraulic Systems

SECTION 04—ENGINE

- Group 0400—Removal and Installation

SECTION 05—ENGINE AUXILIARY SYSTEMS

- Group 0510—Cooling Systems
- Group 0515—Speed Controls
- Group 0520—Intake System
- Group 0560—External Fuel Supply Systems

SECTION 17—FRAME, CHASSIS OR SUPPORTING STRUCTURE

- Group 1749—Chassis Weights

SECTION 18—OPERATOR'S STATION

- Group 1800—Removal and Installation

SECTION 33—EXCAVATOR

- Group 3302—Buckets
- Group 3315—Controls Linkage
- Group 3340—Frames
- Group 3360—Hydraulic System

SECTION 43—SWING, ROTATION OR PIVOTING SYSTEM

- Group 4350—Mechanical Drive Elements
- Group 4360—Hydraulic System

SECTION 9005—OPERATIONAL CHECKOUT PROCEDURE

SECTION 9010—ENGINE OPERATION AND TEST

- Group 05—Theory of Operation
- Group 10—System Operational Checks
- Group 15—Diagnostic Information
- Group 20—Adjustments
- Group 25—Tests

All information, illustrations and specifications contained in this technical manual are based on the latest information available at the time of publication. The right is reserved to make changes at any time without notice.

COPYRIGHT® 1987
DEERE & COMPANY
Moline, Illinois
All rights reserved
A JOHN DEERE ILLUSTRATION

M27;1380F -A1 030387

SECTION AND GROUP CONTENTS —Continued

SECTION 9015—ELECTRICAL SYSTEM OPERATION AND TEST

- Group 05—Theory of Operation
- Group 15—Diagnostic Information
- Group 25—Tests

SECTION 9020—POWER TRAIN OPERATION AND TEST

- Group 05—Theory of Operation
- Group 15—Diagnostic Information
- Group 20—Adjustments
- Group 25—Tests

SECTION 9025—HYDRAULIC SYSTEM OPERATION AND TEST

- Group 05—Theory of Operation
- Group 15—Diagnostic Information
- Group 20—Adjustments
- Group 25—Tests

SECTION 9900—DEALER FABRICATED TOOLS

INTRODUCTION

This manual is part of a total service support program.

FOS Manuals—reference

Technical Manuals—machine service

Component Manuals—component service

Fundamentals of Service (FOS) Manuals cover basic theory of operation, fundamentals of troubleshooting, general maintenance, and basic types of failures and their causes. FOS Manuals are for training new personnel and for reference by experienced technicians.

Technical Manuals are concise service guides for specific machines. Technical manuals are on-the-job guides containing only the vital information needed by an experienced service technician.

Component Technical Manuals are concise service guides for specific components. Component technical manuals are written as stand alone manuals covering multiple machine applications.

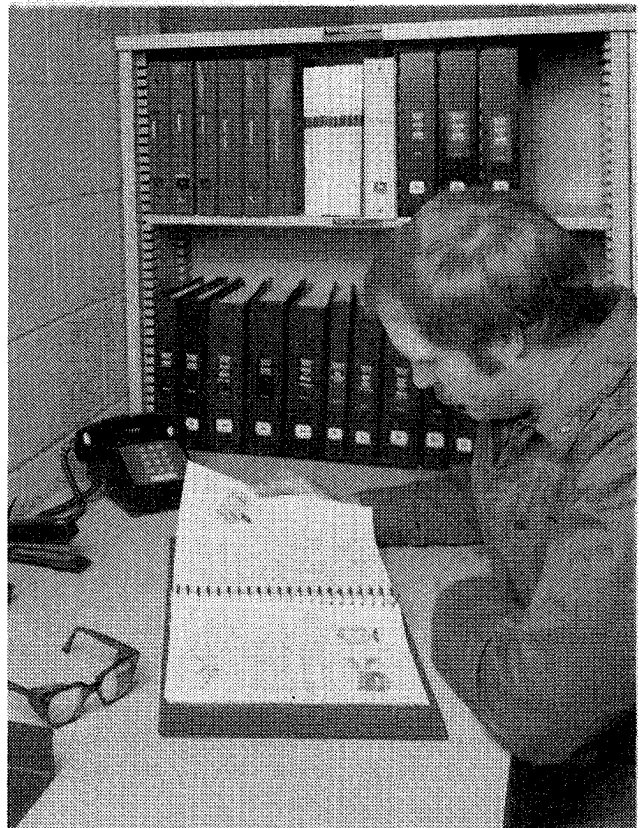

AB6;RW5559 053;INTRO2 030785

FEATURES OF THIS TECHNICAL MANUAL

John Deere ILLUSTRATION format emphasizing illustrations and concise instructions in easy-to-use modules.

Emphasis on diagnosis, analysis, and testing so you can understand the problem and correct it.

Diagnostic information presented with the most logical and easiest to isolate problems first to help you identify the majority of routine failures quickly.

Step-by-step instructions for teardown and assembly.

Summary listing at the beginning of each group of all applicable specifications, wear tolerances, torque values, essential tools, and materials needed to do the job.

An emphasis throughout on safety—so you do the job right without getting hurt.

This technical manual was planned and written for you—an experienced service technician. Keep it in a permanent binder in the shop where it is handy. Refer to it when you need to know correct service procedures or specifications.

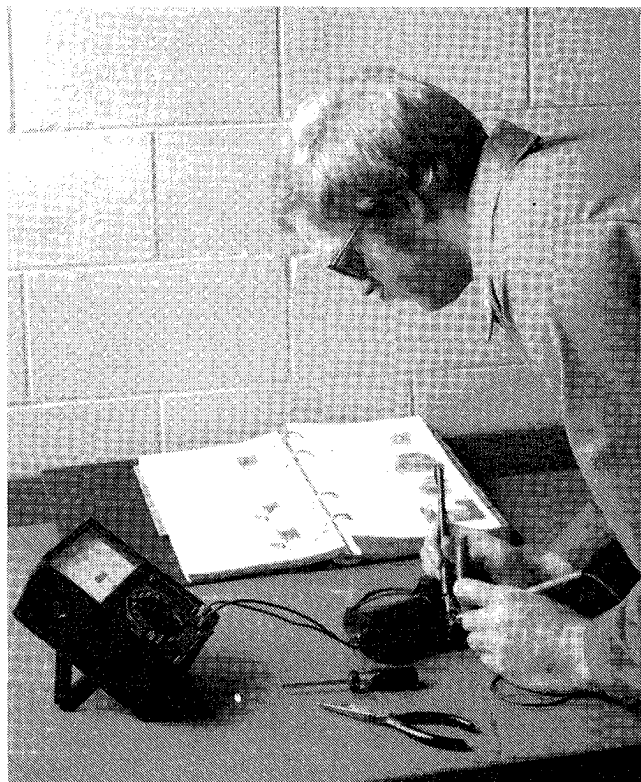

AB6;RW5560 053;INTRO3 071085

RECOGNIZE SAFETY INFORMATION

This is the safety-alert symbol. When you see this symbol on your machine or in this manual, be alert to the potential for personal injury.



AB6;T81389 053;ALERT 071085

UNDERSTAND SIGNAL WORDS

A signal word—DANGER, WARNING, or CAUTION—is used with the safety-alert symbol. DANGER identifies the most serious hazards.

Safety signs with signal word DANGER or WARNING are typically near specific hazards.

General precautions are listed on CAUTION safety signs. CAUTION also calls attention to safety messages in this manual.



AB6;TS187 053;SIGNAL 071085

FOLLOW SAFETY INSTRUCTIONS

Carefully read all safety messages in this manual and on your machine safety signs. Follow recommended precautions and safe operating practices.

Keep safety signs in good condition. Replace missing or damaged safety signs.



AB6;TS188 053;SIGNS 071085

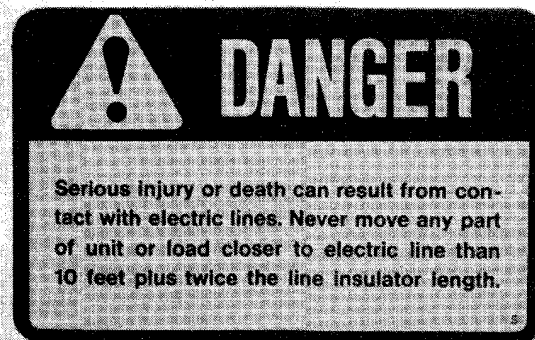

On outside of left console (50 Only)

2TA;T5992AG 02T;05 C59 250486



CAUTION

1. Use caution to avoid contact between boom and overhead obstacles whenever operating, moving or hauling excavator.
2. Never park excavator with tracks pointed downhill.
3. Always lower bucket and blade to ground before leaving operator's station.
4. Before moving excavator, determine which way to move travel levers for intended direction of travel (when blade is not visible from cab, forward movement on travel levers will move excavator rearward).
5. Be sure bystanders are clear of excavator before moving boom.
6. Use caution to avoid sideways tipping when swinging heavy loads to side of tracks.

On outside of left console

018;T6210AK 02T;05 K8 030386



WARNING

1. To prevent serious injury in the event of excavator tipover:
 - Wear seat belt
 - Keep this tipover protective structure including roof on the machine.
 - Replace damaged protective structure, do not repair.
2. Any alterations to this tipover protective structure must be approved by the manufacturer.

*Canopy (TOPS) units—On right rear vertical member
Cab (TOPS) units—On left rear door post*

018;T6307AM 02T;05 K9 250686

*Canopy (TOPS) units—On outside of right and left control pedestals
Cab (TOPS) units—On rear of left control pedestal*

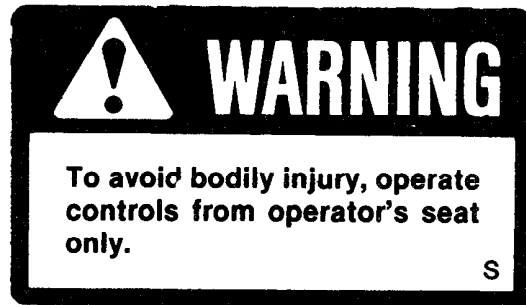

018;T6284AZ 02T;05 K10 030386

USE HANDHOLDS AND STEPS

When you get on and off the machine, use handholds and steps.



018;T6192AH T82;BHSA CM 010686

PREVENT MACHINE RUNAWAY

Avoid possible injury or death from machine runaway.
Do not start engine by shorting across starter terminals.
Do not leave operator's station while engine is running.
NEVER start engine while standing on ground. Start engine only from operator's seat.

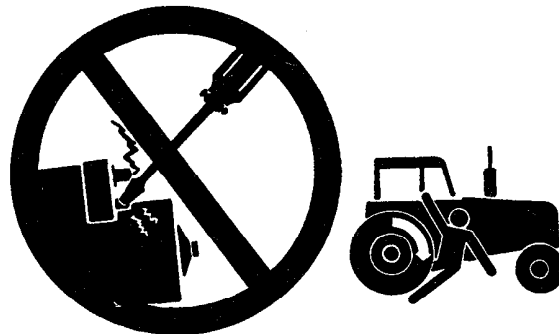

AB6;TS177 T82;BHSA CQ 140286

AVOID POWER LINES

Keep away from power lines. Serious injury or death may result. Never move any part of the machine or load closer to power line than 3 m (10 ft) plus twice the line insulator length.

02T;05 K16 080386

KEEP RIDERS OFF MACHINE

Only allow the operator on the machine. Keep riders off.

Riders on machine are subject to injury such as being struck by foreign objects and being thrown off of the machine. Riders also obstruct the operator's view resulting in the machine being operated in an unsafe manner.



AB6;TS173 053;RIDER 261184

DRIVE EXCAVATOR SAFELY

Before you move the excavator, find out which way to move travel levers for the direction you want to go. If propel motors are in front of the cab, pull the travel levers back to move forward.

02T;05 K14 070386

PREPARE FOR EMERGENCIES

Be prepared if a fire starts.

Keep a first aid kit and fire extinguishers handy.

Keep emergency numbers for doctors, ambulance service, hospital, and fire department near your telephone.



AB6;TS186 053;FIRE2 080785

HANDLE FUEL SAFELY—AVOID FIRES

Handle fuel with care: it is highly flammable. Do not refuel the machine while smoking or when near open flame or sparks.

Always stop engine before refueling machine. Fill fuel tank outdoors.

Prevent fires by keeping machine clean of accumulated trash, grease, and debris. Always clean up spilled fuel.



AB6;TS185 053;FIRE1 240785

HANDLE STARTING FLUID SAFELY

Starting fluid is highly flammable.

Keep all sparks and flame away when using it. To prevent accidental discharge when storing the pressurized can, keep the cap on the container, and store in a cool, protected location.

Do not incinerate or puncture a starting fluid container.



AB6;T6089A U 053;FIRE3 080785

PREVENT BATTERY EXPLOSIONS

Battery gas can explode. Keep sparks and flames away from batteries. Use a flashlight to check battery electrolyte level.

Never check battery charge by placing a metal object across the posts. Use a voltmeter or hydrometer.

Always remove grounded (-) battery clamp first and replace it last.



AB6;TS181 053;EXPL0 180485

AVOID ACID BURNS

Sulfuric acid in battery electrolyte is poisonous. It is strong enough to burn skin, eat holes in clothing, and cause blindness if splashed into eyes.

Avoid the hazard by:

1. Filling batteries in a well-ventilated area.
2. Wearing eye protection and rubber gloves.
3. Avoiding breathing fumes when electrolyte is added.
4. Avoiding spilling or dripping electrolyte.

If you spill acid on yourself:

1. Flush your skin with water.
2. Apply baking soda or lime to help neutralize the acid.
3. Flush your eyes with water for 10-15 minutes. Get medical attention immediately.

If acid is swallowed:

1. Drink large amounts of water or milk.
2. Then drink milk of magnesia, beaten eggs, or vegetable oil.
3. Get medical attention immediately.

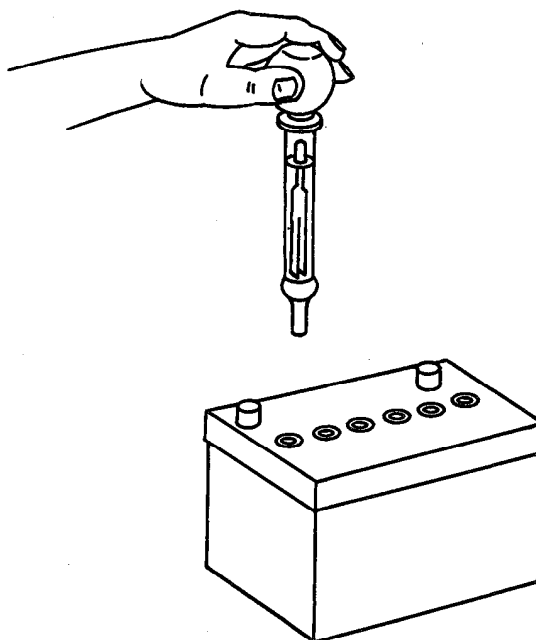

AB6;TS182 053;ACID 180485

PROTECT AGAINST NOISE

Prolonged exposure to loud noise can cause impairment or loss of hearing.

Wear a suitable hearing protective device such as earmuffs (A) or earplugs (B) to protect against objectionable uncomfortable loud noises.



AB6;X7662 053;NOISE 150584

PROTECT AGAINST FLYING DEBRIS

When you drive connecting pins in or out, guard against injury from flying pieces of metal or debris; wear goggles or safety glasses.

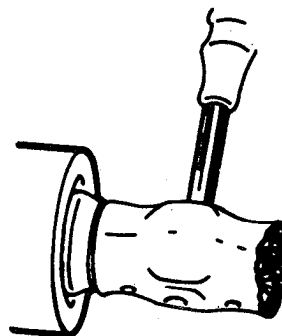

018;T6073AP T82;FLSA AB 130685

WEAR PROTECTIVE CLOTHING

Wear fairly tight clothing. and safety equipment.



AB6;T85056 053;WEAR1 080785

AVOID HIGH-PRESSURE FLUIDS

Escaping fluid under pressure can penetrate the skin causing serious injury. Relieve pressure before disconnecting hydraulic or other lines. Tighten all connections before applying pressure. Keep hands and body away from pinholes and nozzles which eject fluids under high pressure. Use a piece of cardboard to search for leaks.

If ANY fluid is injected into the skin, it must be surgically removed within a few hours by a doctor familiar with this type injury or gangrene may result.

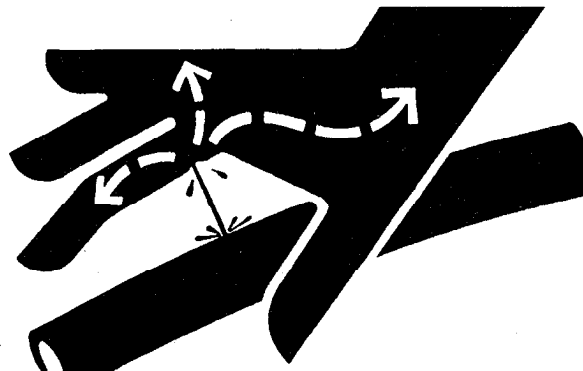

AB6;X9811 053;FLUID 010586

SERVICE EXCAVATOR SAFELY

Never operate the machine if an unsafe condition exists. Attach a "DO NOT OPERATE" tag to the machine.

Be sure you understand a service procedure before working on the machine.

Never lubricate or work on the machine while it is moving.

Always use two people when making checks with the engine running—the operator at the controls, able to see the person doing the checking.

Keep hands away from moving parts.

Never work under a machine raised by the boom. If the machine must be raised, keep a 90—110° angle between boom and arm.

Disconnect battery ground cable (—) before welding on the machine or making adjustments on the engine or electrical system.



**DO NOT
OPERATE**

018;T6283BH 02T;05 C45 140286

REMOVE AND INSTALL TRACK GUARD

1. Remove two cap screws and cap nut (A) to remove track guard (B).

NOTE: To remove inside guard, remove lower roller mount cap screw (C).

2. Install track guard. Apply thread lock and sealer (medium strength) to threads of cap screws and tighten to 137—186 N·m (101—137 lb-ft).

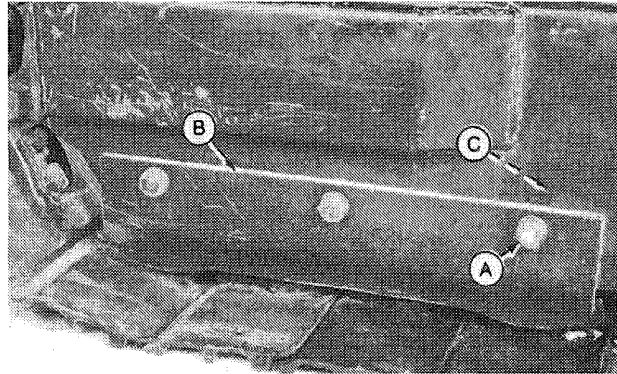

037;T6447D F M22;;0130 -A5 080187

REMOVE AND INSTALL CARRIER ROLLER—30



CAUTION: Grease in track adjusting cylinder is under high pressure. DO NOT remove grease fitting to release track tension.

1. Turn track adjuster relief valve (A) just enough to relieve track tension.
2. Remove wire (C) and loosen cap screw.
3. Remove roller (B) using a hammer and brass drift to drive shaft out of mounting bracket.
4. Install roller. Tighten cap screw making sure cap screw fits into groove of roller shaft. Install wire.
5. Adjust track sag. (See procedure in this group.)

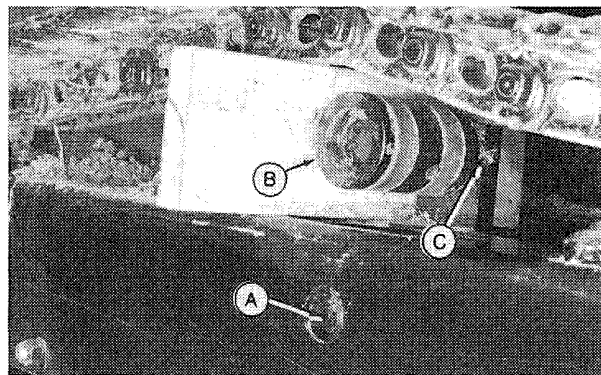

037;M51359 M22;;0130 -A6 080187

DISASSEMBLE AND ASSEMBLE CARRIER ROLLER—30

1. Remove drain plug (A) and drain oil.
2. Remove retaining ring (B).
3. Put assembly in press and push down on shaft to remove parts (C—I).
4. Remove seal (K) and retaining ring (J), if worn or damaged.
5. Clean and dry parts thoroughly. Make sure bearings roll freely. Inspect parts for wear or damage; replace as necessary.
6. Install retaining ring (J) into roller (L).
7. Assemble parts (E—H). Use a press to install shaft assembly into roller.
8. Put O-ring on cover and install cover with retaining ring (B).
9. Install thrust washer (I).
10. Install seal (K) using a press.
11. Put approximately 45 mL (1.5 oz) of recommended oil in roller. (See Section I, Group IV.)
12. Put pipe sealant with TEFLON on threads of plug (A) and install plug.

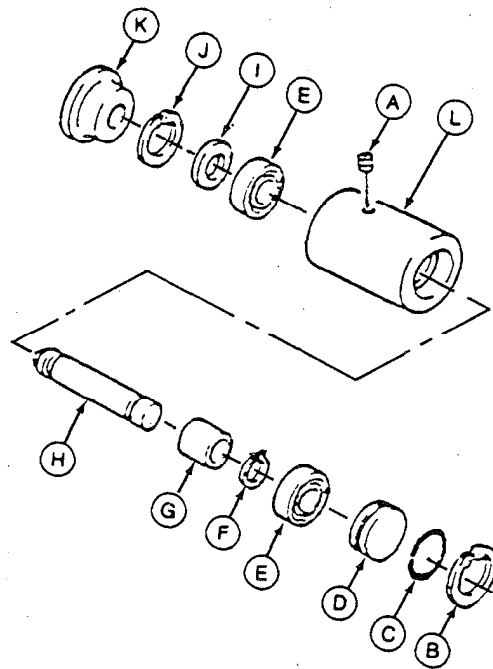

- | | |
|--------------------|------------------|
| A—Plug | G—Bushing |
| B—Retaining Ring | H—Shaft |
| C—O-Ring | I—Thrust Washer |
| D—End Cover | J—Retaining Ring |
| E—Bearing (2 used) | K—Seal |
| F—Retaining Ring | L—Roller |

037/M51360 M22;;0130 -A7 230287

REMOVE AND INSTALL CARRIER ROLLER— 50



CAUTION: Grease in track adjusting cylinder is under high pressure. DO NOT remove grease fitting to release track tension.

1. Turn track adjuster relief valve (A) just enough to relieve track tension.
2. Lift track chain off carrier roller. Remove cap screw (B), washer and nut to remove roller.
3. Install roller, cap screw (B), washer and nut. Tighten cap screw and remove blocks.
4. Adjust track sag. (See procedure in this group.)

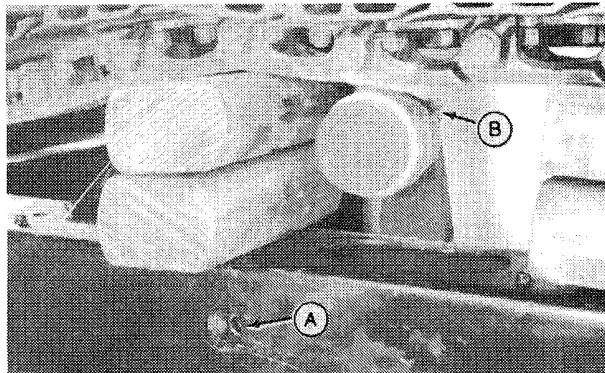

037;T6447A T M22;;0130 -A8 080187

REPAIR CARRIER ROLLER—50

1. Remove plug (F) and drain oil.
2. Remove snap ring (N).
3. Use a press to remove parts (G—M) by pushing on shaft. Dissassemble shaft as necessary for repair.
4. Remove parts (A—D).
5. Clean and dry parts thoroughly. Make sure bearings roll freely. Inspect parts for wear or damage; replace as necessary.
6. Install snap ring (D).
7. Put snap rings (I and J) and bearings (H and K) on shaft.
8. Install shaft assembly in roller against snap ring (D) using a press.
9. Put O-ring (M) on cover (L). Install cover and snap ring (N).
10. Put pipe sealant with TEFLON on threads of plug (F) and install plug. Pour approximately 85 mL (2.9 oz) of recommended oil in open end of roller. (See Section I, Group IV.)
11. Install seal (C) using a press.
12. Install cover (B) and snap ring (A).

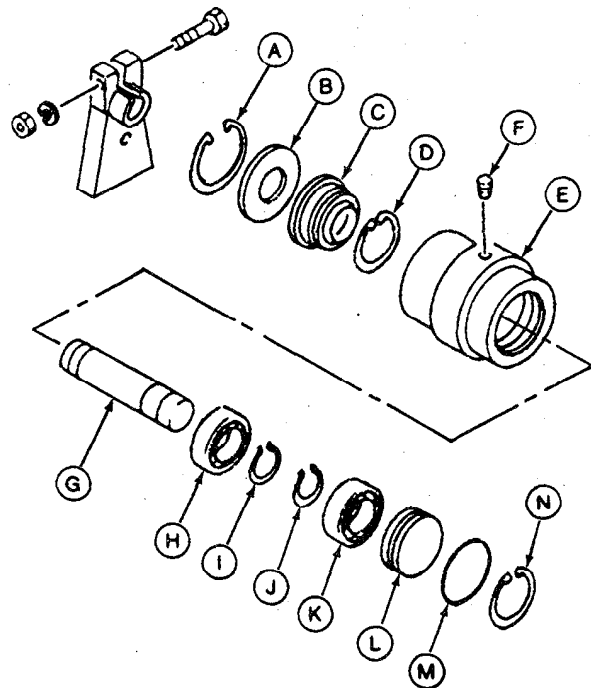

A—Snap Ring
 B—Cover
 C—Seal
 D—Snap Ring
 E—Roller
 F—Plug
 G—Shaft

H—Bearing
 I—Snap Ring
 J—Snap Ring
 K—Bearing
 L—Cover
 M—O-Ring
 N—Ring

037;T6447A U M22;0130 -A9 230287

REMOVE AND INSTALL TRACK ROLLER



CAUTION: Grease in track adjusting cylinder is under high pressure. **DO NOT** remove grease fitting to release track tension.

1. Turn track adjuster relief valve (A) just enough to relieve track tension.
2. Lift side of unit high enough to permit roller removal. Support unit under the frame with blocks or jacks to prevent accidental lowering of unit.

NOTE: Cap screw (B) on front track roller is longer than cap screws for other rollers.

3. Remove nut and cap screw to remove track roller.
4. Install roller with flat side of end covers facing up towards frame.
5. Install and tighten cap screw to 137—186 N·m (101—137 lb-ft). Turn roller by hand to make sure it turns freely.

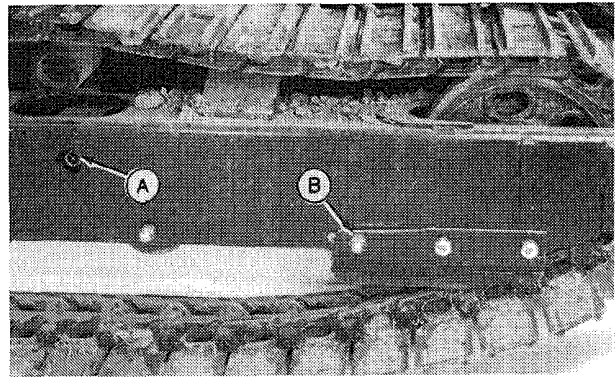

037;M51381 M22;;5010F A4 101186

REPAIR TRACK ROLLER—30

1. Remove cover (J), seal (I) and snap ring (H) from round end of roller shaft (F) using a pry bar.
2. Drain oil from roller.
3. Remove shaft (F) and bearing (G) from roller by pressing on shaft end with flats.
4. Remove parts (A—D).
5. Clean and dry parts.
6. Measure shaft O.D. (K) and roller I.D. (L). Replace parts that do not meet specifications.

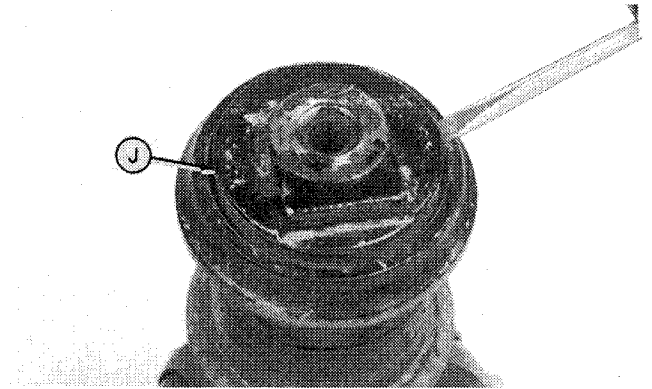

TRACK ROLLER SPECIFICATIONS

Roller Shaft O.D. (K) 30 mm (1.18 in.)
 Roller I.D. (L) 62 mm (2.44 in.)

7. Install snap ring (H).
8. Install bearing (G) and shaft (F) using a press and driver. Install bearing (D) and snap ring (C).
9. Install seal (B) using a press and a piece of pipe that will fit over shaft. Install cover (A).
10. Put 70 mL (2.5 oz) of recommended oil into open end of roller.
11. Install seal (I) using a press and a piece of pipe. Install cover (J) making sure mounting surfaces of end cap are aligned.

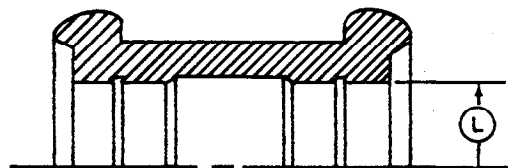
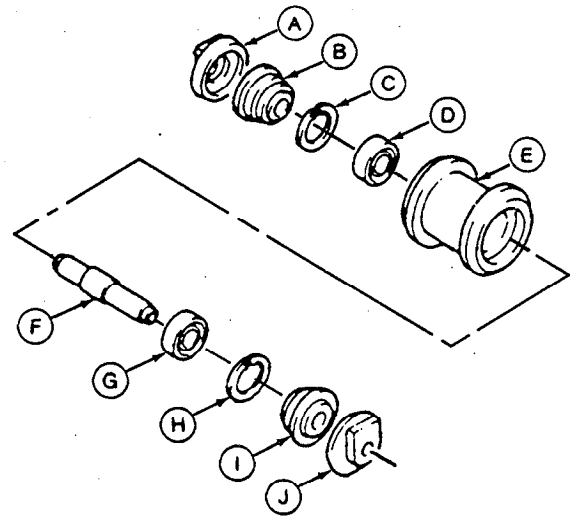

- | | |
|-------------|---------------|
| A—Cover | G—Bearing |
| B—Seal | H—Snap Ring |
| C—Snap Ring | I—Seal |
| D—Bearing | J—Cover |
| E—Roller | K—Shaft O.D. |
| F—Shaft | L—Roller I.D. |

DISASSEMBLE TRACK ROLLER —50

1. Remove plug (A) to drain oil.
2. Remove snap ring (B). Use hammer and driver to push shaft assembly (C) from roller and cover (F).

IMPORTANT: Keep seal rings as matched sets with seal faces together to protect the surface.

3. Remove seals (D) from roller (E).
4. Remove O-ring (G) from cover.

NOTE: Only remove bushings if replacement is necessary.

5. Remove bushings (H) using a two-jaw puller.
6. Clean and dry all parts thoroughly. Inspect parts for wear or damage.

Measure bushing I.D. and roller shaft O.D. Replace parts that are damaged or do not meet specifications.

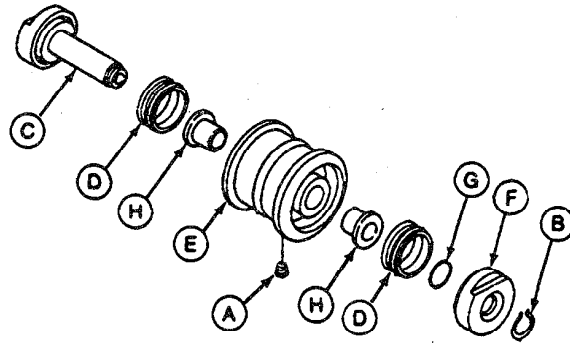

- | | |
|------------------|--------------------|
| A—Drain Plug | E—Track Roller |
| B—Snap Ring | F—Cover |
| C—Shaft Assembly | G—O-Ring |
| D—Seal Assembly | H—Bushing (2 used) |

TRACK ROLLER SPECIFICATIONS

Bushing	
Maximum I.D.	35.4 mm (1.39 in.)
Shaft	
Minimum O.D.	34.5 mm (1.36 in.)

037;T6447D C M22;;0130 -A11 230287

INSPECT METAL FACE SEALS

1. Inspect for the following conditions to determine if seals can be reused:

- a. The narrow, highly polished sealing area (E) must be in the outer half of seal ring face (D).
- b. Sealing area must be uniform and concentric with the I.D. and O.D. of seal ring (A).
- c. Sealing area must not be chipped, nicked, or scratched.

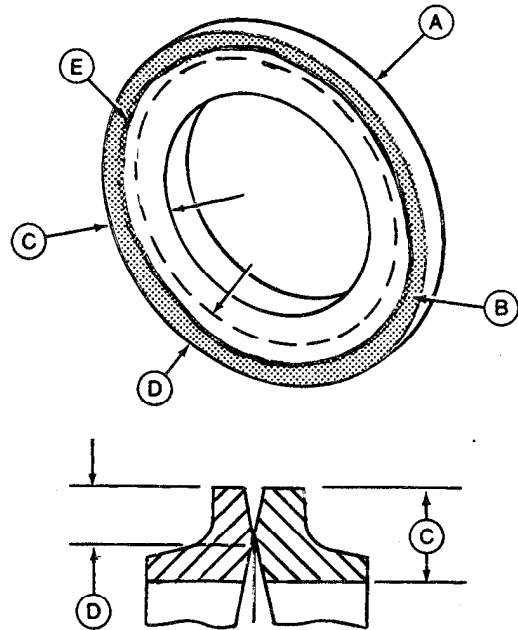

A—Seal Ring
 B—Worn Area (shaded area)
 C—Seal Ring Face
 D—Outer Half of Seal Ring Face
 E—Sealing Area (dark line)

4AG;T85079 T47;0130 5939HQ 140984

2. Illustration shows examples of worn seal rings (A).

I—Sealing area (D) is in inner half of seal ring face (C).

II—Sealing area (D) not concentric with I.D. and O.D. of seal ring.

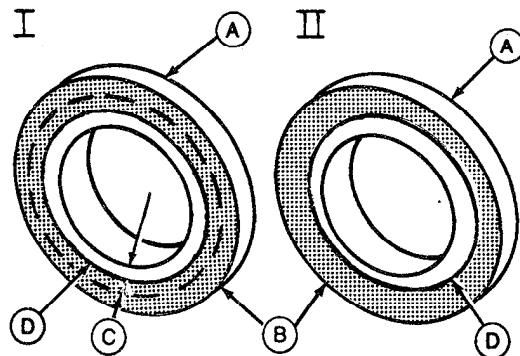

A—Seal Ring
 B—Worn Area (shaded area)
 C—Inner Half of Seal Ring Face
 D—Sealing Area (dark line)

4AG;T85080 T47;0130 5939HR 140984

3. Clean seals to be reused by removing all foreign material from seal rings, except seal face (A), using a scraper or a stiff bristled fiber brush.

4. Wash seal rings and O-rings using a volatile, non-petroleum base solvent to remove all oil. Thoroughly dry parts using a lint-free tissue.

Apply a thin film of oil to seal ring face. Put face of seal rings together and hold using tape.

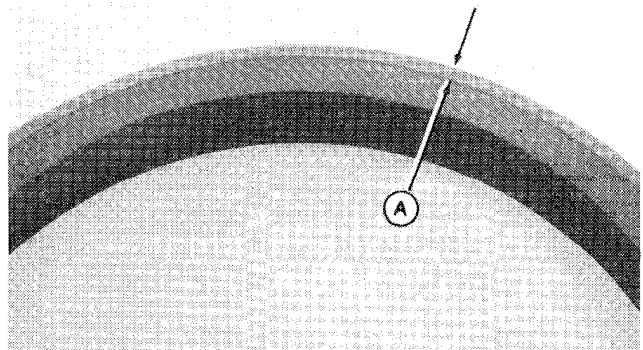

4AG;T82840 T47;0130 5939HS 140984

ASSEMBLE TRACK ROLLER—50

1. Use a press to push bushings into track roller so bushing flange is tight against roller.

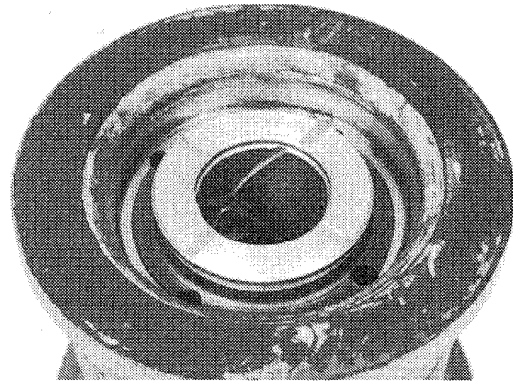

037;T6447D D M22;;0130 -A12 080187

IMPORTANT: O-rings and seat surfaces for O-rings must be clean, dry and oil free. A thin film of oil can be applied to O.D. of O-ring to ease assembly. Using too much oil will cause O-ring to rotate and leak.

2. Use DF1021 Roller Seal Installation Tool to install one half of floating ring seal into roller cover.

Set guide collar (B) on roller cover (C). Set floating ring seal squarely into collar.

Use push collar (A) to push seal and O-ring into roller cover. Turn the push collar to seat O-ring uniformly.

IMPORTANT: The distance between top of seal ring and top of O-ring must be uniform around the circumference.

Install seal ring and O-ring in roller cover with shaft using same procedure.

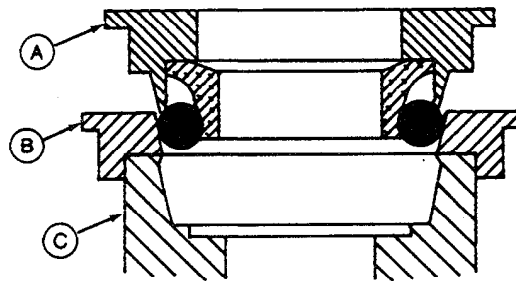
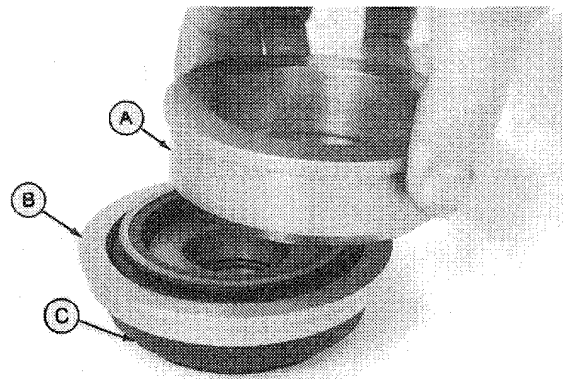

037;T6447B T T6447B U M22;;0130 -A13 080187

**Thank you very much for
your reading. Please Click
Here. Then Get COMPLETE
MANUAL. NO WAITING**



NOTE:

**If there is no response to
click on the link above,
please download the PDF
document first and then
click on it.**

3. Use matching seal ring half from cover with shaft and set seal ring squarely into roller bore.
4. Wipe any finger prints and foreign material off seal ring face using a lint-free tissue. Apply a thin film of oil on bushings and each seal ring face only.
5. Carefully install shaft assembly into roller (E).
6. Install O-ring (G) into cover (F).

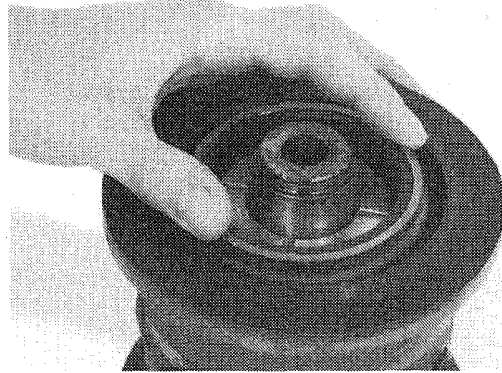

Wipe any finger prints and foreign material off seal ring face using a lint-free tissue. Apply a thin film of oil on each seal ring face only.

7. Put cover on shaft and install snap ring (B). If snap ring cannot be installed, use a press to push shaft through bracket.
8. Fill idler with approximately 150 mL (5.07 oz) of recommended oil. (See Section I, Group IV.)

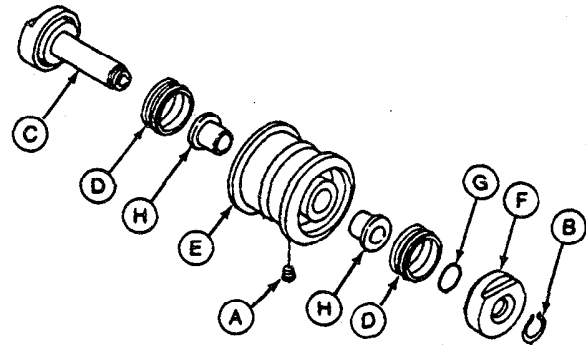

Put pipe sealant with TEFLON on threads of plug (A). Install and tighten plug.

- | | |
|------------------|--------------------|
| A—Drain Plug | E—Track Roller |
| B—Snap Ring | F—Cover |
| C—Shaft Assembly | G—O-Ring |
| D—Seal Assembly | H—Bushing (2 used) |

037;T6447B S T6447D C M22;;0130 -A14 230287

REMOVE AND INSTALL TRACK SHOE—50

1. Remove four nuts (A) and cap screws to remove shoe.
2. Clean paint, dirt and debris from mounting surfaces of shoes and links.
3. Apply oil to cap screw threads and bearing surface on head before installing cap screws.
4. Install track shoe. Tighten cap screws to 147—196 N·m (108—145 lb-ft).

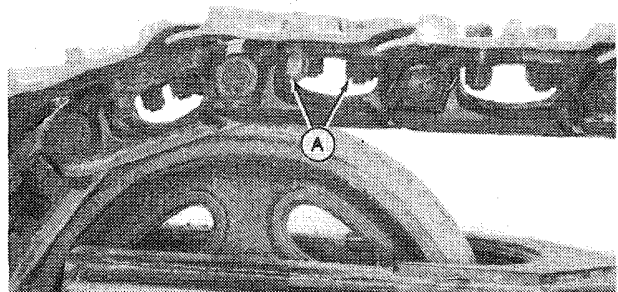

037;T6447D E M22;;0130 -A15 230287

REPLACE TRACK

⚠ CAUTION: Grease in track adjusting cylinder is under extreme pressure. **DO NOT** remove grease fitting to release track tension.

1. Loosen track adjuster relief valve, just enough to release track tension.
2. Put wood block in front of idler to prevent track from falling when link pin is removed.

⚠ CAUTION: The approximate weight of track chain is:

30.	165 kg (364 lb).
50.	248 kg (547 lb).

NOTE: Step 3 is done on the 50 only.

3. Remove two track shoes for easy access to pin. (See procedure in this group.)
4. Remove wire (A). Use hammer and driver to remove master pin (B) and carefully lower track to the ground.
5. Lift side of unit just high enough to remove track, if necessary.
6. Connect track by installing master pin (B). Install wire (A).

NOTE: Step 7 is done on 50 only.

7. Install two track shoes. (See procedure in this group.)
8. Tighten track relief valve and adjust track sag. (See procedure in this group.)

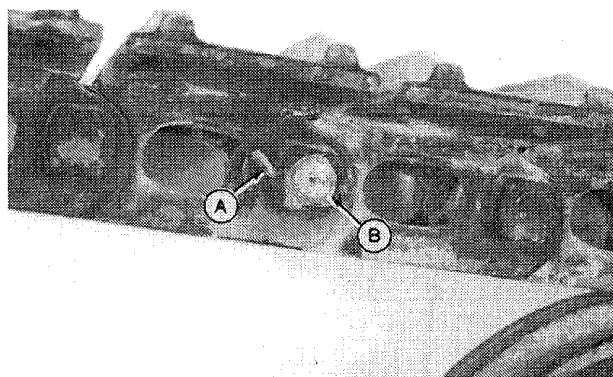

037;M51511 M22;;0130 -A16 080187