

2360 WindRower and 160 Platform



JOHN DEERE

TECHNICAL MANUAL 2360 WindRower and 160 Platform

TM1300 (01JUN85) English

John Deere Welland Works
TM1300 (01JUN85)

LITHO IN U.S.A.
ENGLISH



TM-1300

**2360 WINDROWER AND 160 PLATFORM
TECHNICAL MANUAL**

SECTION AND GROUP CONTENTS

SECTION 10—GENERAL

- GROUP 05—Safety
- GROUP 10—Specifications
- GROUP 15—Predelivery, Delivery and After-Sale Service
- GROUP 20—Tune Up
- GROUP 25—Lubrication

SECTION 15—RADIATOR, FAN, AND ACCESSORY BELTS

- GROUP 05—Radiator, Fan, and Accessory Belts

SECTION 20—DIESEL ENGINE REPAIR

- GROUP 01—Engine Removal and Installation
- GROUP 05—Cylinder Head, Valves, Timing Gear Train and Camshaft
- GROUP 10—Cylinder Block, Liners, Pistons and Rods
- GROUP 15—Crankshaft, Main Bearing and Flywheel
- GROUP 20—Lubrication System
- GROUP 25—Cooling System

SECTION 25—GASOLINE ENGINE REPAIR

- GROUP 05—Engine Removal and Installation
- GROUP 10—Basic Engine
- GROUP 15—Cylinder Head, Valves, and Camshaft
- GROUP 20—Block, Pistons, and Connecting Rods
- GROUP 25—Crankshaft and Main Bearings
- GROUP 30—Lubrication System
- GROUP 25—Cooling System

SECTION 30—DIESEL-FUEL AND AIR

- GROUP 05—Air Intake System
- GROUP 10—Diesel Fuel System

SECTION 35—GASOLINE-FUEL AND AIR

- GROUP 01—General
- GROUP 05—Air Filtering System
- GROUP 10—Fuel System
- GROUP 15—Carburetor
- GROUP 20—Governor
- GROUP 25—Throttle Control Linkage

SECTION 40—ELECTRICAL

- GROUP 05—Battery
- GROUP 10—Starting System Diesel
- GROUP 15—Starting System Gasoline
- GROUP 20—Ignition System
- GROUP 25—Charging System
- GROUP 30—Lights, Switches, and Accessories

SECTION 50—POWER TRAIN

- GROUP 05—Ground Drive System
- GROUP 10—Piston Pump Assembly
- GROUP 15—Wheel Motor
- GROUP 20—Power Wheel
- GROUP 25—Platform Drive System

SECTION 60—STEERING AND BRAKES

- GROUP 05—Steering
- GROUP 10—Brakes

All information, illustrations and specifications contained in this technical manual are based on the latest information available at the time of publication. The right is reserved to make changes at any time without notice.

COPYRIGHT® 1985
DEERE & COMPANY
Moline, Illinois
All rights reserved
A JOHN DEERE ILLUSTRATION

W07;0000 A 250685

SECTION AND GROUP CONTENTS

SECTION 70—HYDRAULICS

- GROUP 10—Hydraulic Circuit
- GROUP 15—Double Gear Charge Pump
- GROUP 20—Platform, Deck Shift, and Valves
- GROUP 25—Platform Lift Cylinders
- GROUP 30—Platform Gear Pump

SECTION 80—MISCELLANEOUS

- GROUP 05—Walking Beam
- GROUP 10—Caster Wheel
- GROUP 15—Caster Wheel/Hub
- GROUP 20—Wheels and Tires

SECTION 90—OPERATOR STATION

SECTION 100—DRAPER PLATFORM

- GROUP 05—Specifications
- GROUP 10—Power Train
- GROUP 15—Hydraulics
- GROUP 20—Cutting Components

INTRODUCTION

This technical manual is part of a twin concept of service:

FOS Manuals—for reference

Technical Manuals—for actual service

The two kinds of manuals work as a team to give you both the general background and technical details of shop service.

Fundamentals of Service (FOS) manuals cover basic theory of operation, fundamentals of trouble shooting, general maintenance, and basic types of failures and their causes. FOS Manuals are for training new people and for reference by experienced technicians.

Technical Manuals are concise service guides for a specific machine. Technical Manuals are on-the-job guides containing only vital information needed by an experienced technician.

Using the technical manual as a guide, will reduce error and costly delay. It will also assure you the best in finished service work.

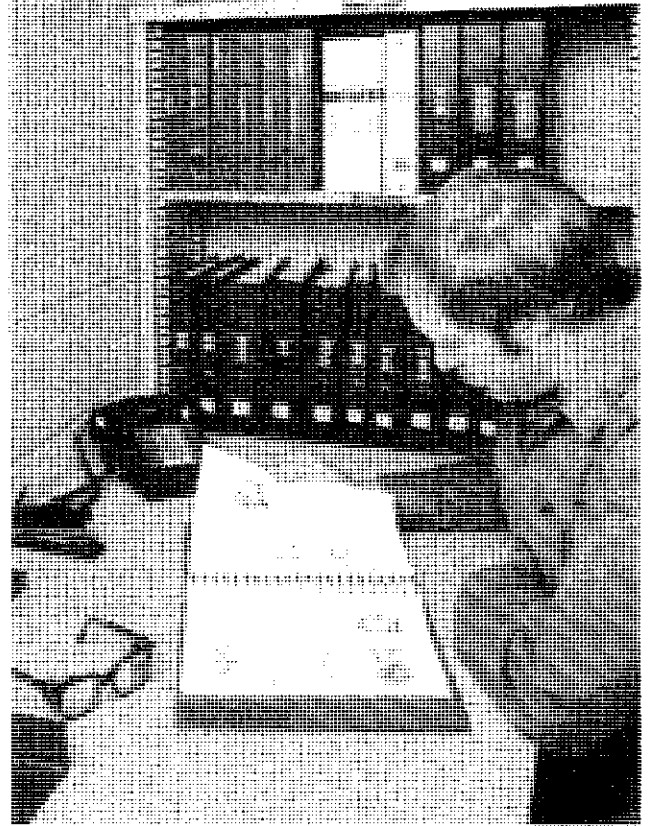

5EA;RW5559 W07;0000 B 170185

FEATURES OF THIS TECHNICAL MANUAL

- **John Deere ILLUSTRATION format emphasizing more detailed pictures and fewer words.**
- **Instructions and illustrations grouped together in easy-to-use modules with exploded views showing parts relationship.**
- **Categorized by two sections: Repair Sections identified by green tabs and Operation and Tests Sections identified by yellow tabs.**
- **Removal and installation groups preceding some repair groups. These groups show how to remove and install components from the machine rather than from major components. They also show how to acquire access to major components of a machine.**

This technical manual was planned and written for you—an experienced technician. Keep it in a permanent binder in the shop where it is handy. Refer to it whenever in doubt about correct service procedures or specifications.

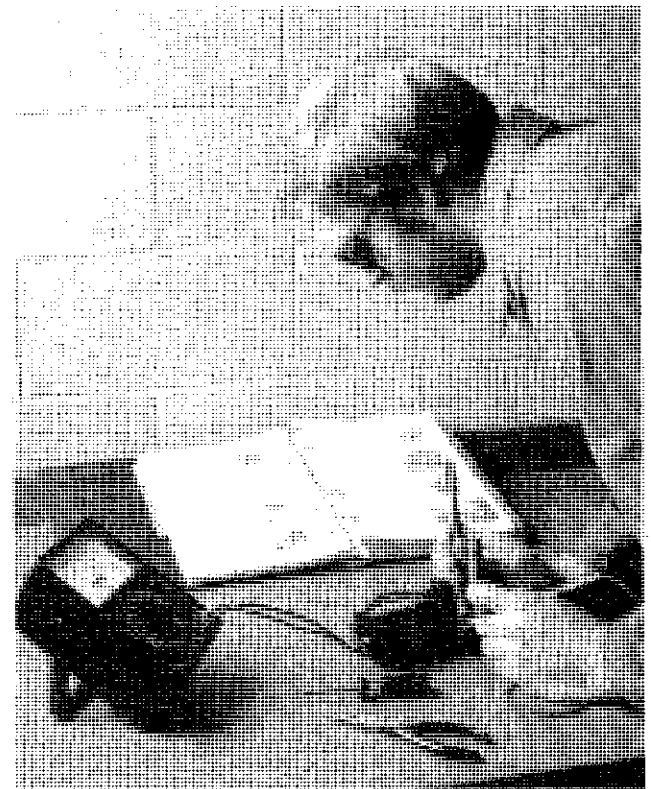

5EA;RW5560 W07;0000 C 170185

OBSERVE IMPORTANT MESSAGES

Messages labeled IMPORTANT will appear in this manual and/or on the machine to provide specific instructions for performing adjustments, services, etc. If these instructions are not followed, it could result in damage to the machine.

5EA; W02;;0000 G 230484

OBSERVE NOTES

The word NOTE is followed by a statement that identifies a qualification or exception to a previous statement. A NOTE may also identify nice-to-know information pertinent to, but not directly related to the previous statement.

5EA; W02;;0000 F 230484

OPERATE WINDROWER SAFELY

Refer to the windrower operator's manual for complete operating instructions.

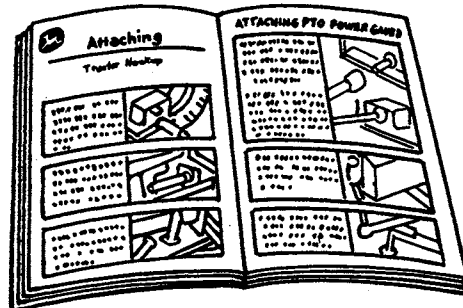

5EA;W9756 W07;;0000 D 031284

METRIC AND ENGLISH DESIGN

The 2360 Windrower, except the diesel engine, is of U.S. customary design. The diesel engine is of metric design. Most hardware is U.S. customary and must be replaced with identical hardware. Measurements in this manual will appear with metric first, followed by U.S. customary equivalents.

W07;;0000 E 031284

DO NOT MODIFY MACHINE

Unauthorized modifications to the machine may impair the function and/or safety and affect machine life.

W01;;12SY H 040485

NEW OR REVISED PAGES

Whenever new or revised pages are provided, insert them into the manual immediately. This way your technical manual will always be up to date and be a valuable asset to your Service Department.

5EA; W02;;0000 E 230484

SPECIAL TOOLS

Special tools required to perform service or adjustment, are found in the beginning of each group throughout the manual.

5EA; W02;;0000 D 040484

Section 10 GENERAL

CONTENTS

	Page
GROUP 05—SAFETY	
Safety	10-05-01
GROUP 10—SPECIFICATIONS	
Machine Specifications	10-10-01
Torque Specifications	10-10-06
GROUP 15—PREDELIVERY, DELIVERY AND AFTER-SALE	
Temporary Storage	10-15-01
Predelivery Service	10-15-02
Delivery Service	10-15-15
After-Sale Service	10-15-16
GROUP 20—TUNE-UP	
General	10-20-01
Preliminary Engine Testing	10-20-01
Engine Tune-Up	10-20-02
Miscellaneous Testing	10-20-06
GROUP 25—LUBRICATION	
General	10-25-01
Engine Lubricating Oils	10-25-01
Storing Lubricants	10-25-02
Lubricants	10-25-02

OBSERVE SAFETY SIGNS AND MESSAGES



CAUTION: This message is used for general reminders of good safety practices or to direct attention to unsafe practices. The message will appear in your operator's manual and/or the sign will appear on the machine with the color combination of yellow and black.

WARNING: This message denotes a specific potential hazard. The sign will be displayed on the machine in areas of potential hazard. The sign will have the color combination of yellow and black.

DANGER: This message denotes the most serious specific potential hazard. The sign will be displayed on the machine in areas of potential hazard. The sign will have the color combination of red and white.



00A:T27999 N W01;GSY A 030383

STAY CLEAR OF MOVING WINDROWER

Be sure everyone is clear of windrower and platform before starting engine or moving steering wheel. Windrower will move if steering wheel is turned even if ground speed control lever is in neutral.

Never try to get on or off a moving windrower.

Before dismounting, place the ground speed control lever in NEUTRAL, engage the parking brake and lower the platform to the ground. Stop the engine and remove the key.

Never attempt to start or operate the Windrower except from operator's station.

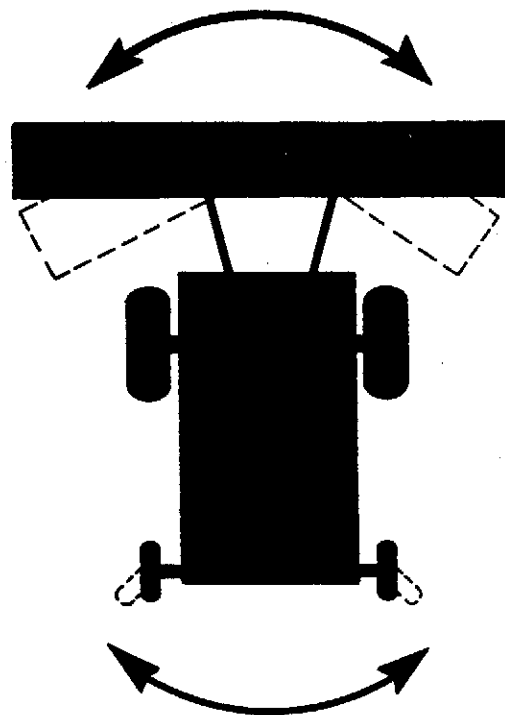

3MA;W9743 W07;;2SY P 051084

TRANSPORT WINDROWER SAFELY DOWNHILL

Use care when driving windrower down steep grades (A). Move ground speed control lever (B) to reduce speed.

Lower platform to maintain stability. Raise completely at bottom of grade.

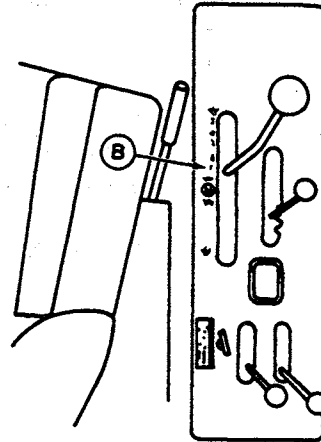
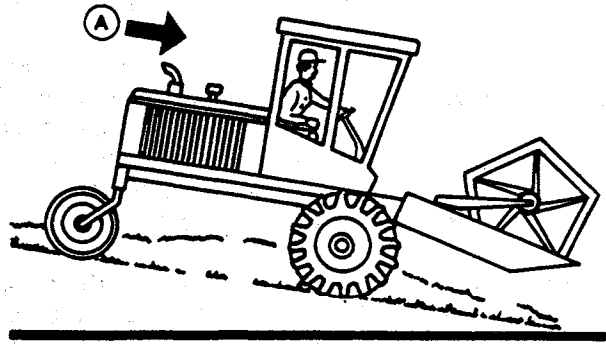

3MA;W9744 W07;;2SY Q 051084

PRACTICE SAFE MAINTENANCE

Know where the first aid kit and fire extinguisher are located and how to use them.

Always park windrower on level ground, shut off engine, engage parking brake, and remove key before servicing.

Use lifting equipment and safety stands having adequate strength for job being performed.

When working on wheels or tires, be sure to place jack and safety stands under axle and block wheels to prevent machine from rolling.

Determine if a mechanism has stored energy before disassembly.

Replace all shields removed for servicing.

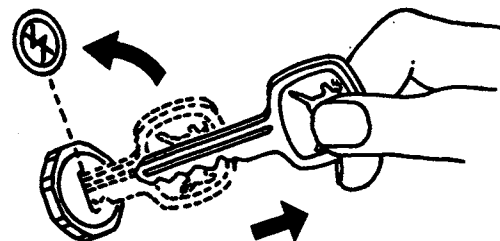
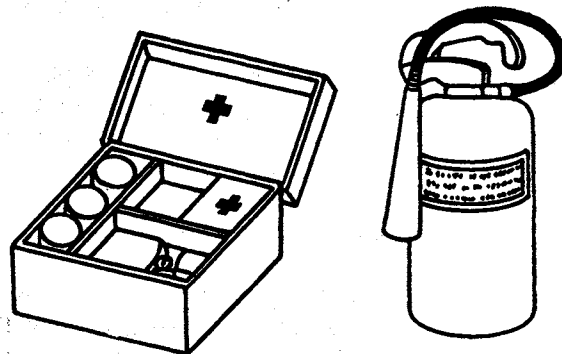

2MA;W9764 W9765 W07;;1005 A 031284

AVOID HIGH-PRESSURE FLUIDS

Escaping fluid under pressure can penetrate the skin causing serious injury. Relieve pressure before disconnecting hydraulic or other lines. Tighten all connections before applying pressure. Keep hands and body away from pinholes and nozzles which eject fluids under high pressure. Use a piece of cardboard or paper to search for leaks.

If ANY fluid is injected into the skin, it must be surgically removed within a few hours by a doctor familiar with this type injury or gangrene may result.

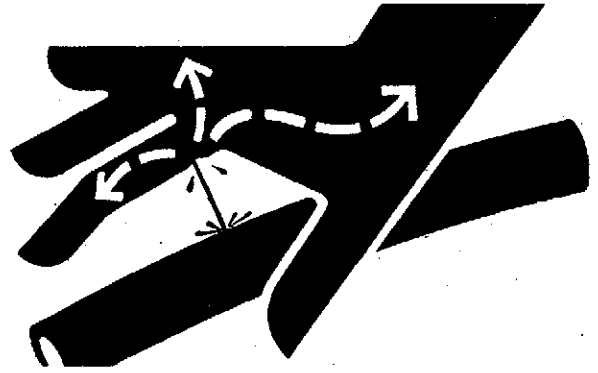

AB6;X9811 053;FLUID 100584

SERVICE TIRES SAFELY

Failure to follow proper procedures when mounting a tire on a wheel or rim can produce an explosion which may result in serious injury or death. Do not attempt to mount a tire unless you have the proper equipment and experience to perform the job. Have it done by your John Deere dealer or a qualified tire repair service.

When sealing tire beads on rims, never exceed 35 psi (241 kPa) (2.4 bar) or maximum inflation pressures specified by tire manufacturers for mounting tires. Inflation beyond this maximum pressure may break the bead, or even the rim, with dangerous explosive force. If both beads are not seated when the maximum recommended pressure is reached, deflate, reposition tire, relubricate bead and reinflate.

Detailed tire mounting instructions, including necessary safety precautions, are contained in John Deere Fundamentals of Service (FOS) Manual 55, Tires and Tracks, available through your John Deere dealer. Such information is also available from the Rubber Manufacturers Association and from tire manufacturers.

- A—Use a Safety Cage If Available.
- B—Do Not Stand Over Tire. Use a Clip-on Chuck and Extension Hose.

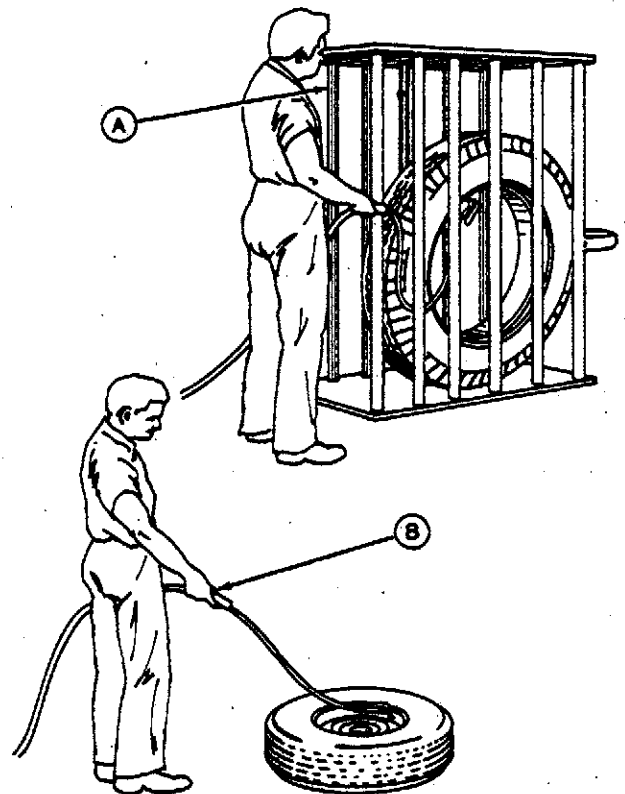

AB6;TS0123 053;TIRE 100584

KEEP SERVICE AREA CLEAN

Keep the service area clean and dry; wet or oily floors are slippery. Wet spots can be dangerous when working with electrical equipment.

Be sure all electrical outlets and tools are properly grounded.

Use adequate light for the job at hand.



5EA;W9966 W02;1010 E 230484

AVOID EXPLOSIONS OR FIRE



CAUTION: Batteries produce explosive gas. Before using booster batteries, read instructions in Operator's Manual.

Before connecting or disconnecting battery charger, turn the charger off to avoid sparks. See Instructions in Operator's Manual.

Be careful with starting fluid or any type of fuel.

Never smoke while handling fuel.

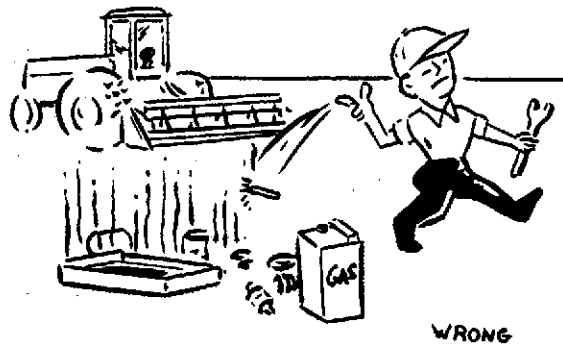

WRONG

2MA;W9739 W07;1005 B 240685

WEAR PROPER PROTECTIVE EQUIPMENT

Ear plugs or ear muffs.

Heavy work gloves (when handling sharp objects or parts).

Safety shoes with slip-resistant soles.

Close fitting work clothes.

Safety glasses or goggles.

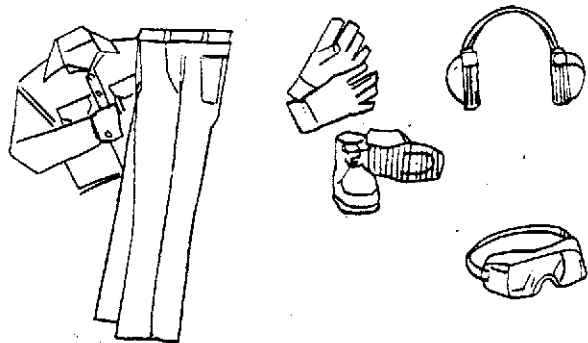

5EA;TY8340 W02;1010 J 230484

PROTECT AGAINST NOISE

Prolonged exposure to loud noise can cause impairment or loss of hearing.

Wear a suitable hearing protective device such as earmuffs (A) or earplugs (B) to protect against objectionable uncomfortable loud noises.

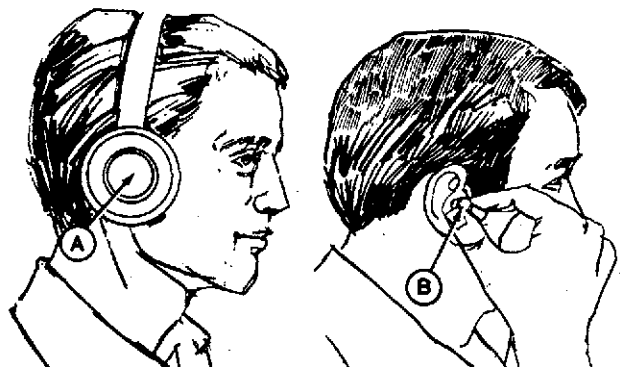

AB6;X7662 053;NOISE 150584

Section 20

DIESEL ENGINE REPAIR

CONTENTS

	Page		Page
GROUP 01—ENGINE REMOVAL AND INSTALLATION			
Special Tools	20-01-01	Measure Camshaft End Play	20-05-25
Torque	20-01-01	Measure Camshaft	20-05-26
Remove Engine.	20-01-01	Install Camshaft.	20-05-27
Install Engine	20-01-12	Remove and Repair Balancer Shafts	20-05-29
GROUP 05—CYLINDER HEAD, VALVES, TIMING GEAR TRAIN AND CAMSHAFT			
Special Tools	20-05-01	Install Balancer Shafts.	20-05-31
Cylinder Head Specifications	20-05-01	Remove Timing Gear Train and Front Plate	20-05-32
Valve Lift and Valve Clearance Specifications	20-05-04	Replace Idler Gear Bushing.	20-05-35
Rocker Arm Assembly Specifications	20-05-04	Replacing Idler Shaft.	20-05-36
Camshaft Specifications	20-05-06	Install Front Plate and Timing Gear Train.	20-05-37
Balancer Shafts Specifications	20-05-07	GROUP 10—CYLINDER BLOCK, LINERS, PISTONS AND RODS	
Timing Gear Train Specifications	20-05-08	Special Tools	20-10-01
Adjust Valve Clearance	20-05-11	Cylinder Liner Specifications	20-10-01
Measure Valve Lift	20-05-12	Cylinder Block Specifications	20-10-02
Remove and Install Rocker Arm Cover	20-05-12	Connecting Rod and Piston Specifications	20-10-04
Remove Rocker Arm Assembly, Pushrods and Cam Followers	20-05-12	Measure Connecting Rod Clearance	20-10-06
Inspect Pushrods	20-05-13	Remove Connecting Rod and Piston	20-10-07
Disassemble and Inspect Rocker Arm Assembly	20-05-13	Measure Crankshaft Rod Diameter	20-10-07
Assemble Rocker Arm Assembly.	20-05-14	Measure Connecting Rod	20-10-08
Measure Cam Followers.	20-05-15	Remove Piston Ring	20-10-08
Install Cam Followers, Pushrods, and Rocker Arm Assembly	20-05-15	Check Piston	20-10-08
Remove Cylinder Head	20-05-16	Remove Piston From Rod.	20-10-09
Measure Valve Recession.	20-05-17	Measure Piston Pin.	20-10-09
Remove Valves.	20-05-17	Replacing Piston Pin Bushing.	20-10-10
Cylinder Head Measurement	20-05-18	Cleaning Piston	20-10-11
Removing Valve Seat	20-05-19	Remove Cylinder Liner.	20-10-13
Installing Valve Seat	20-05-20	Measure Piston Clearance	20-10-14
Grind Valve Seat	20-05-20	Deglaze Cylinder Liner and Clean O-Ring Grooves	20-10-15
Grind Valve	20-05-21	Clean Piston Cooling Orifice	20-10-15
Measure Valve Spring Strength.	20-05-21	Install Cylinder Liner and Block.	20-10-16
Install Valve in Cylinder Head.	20-05-21	Measure Cylinder Block	20-10-18
Install Cylinder Head.	20-05-22	Select Piston Type	20-10-19
Remove and Install Timing Gear Cover	20-05-22	Install Connecting Rod and Piston.	20-10-20
Remove and Install Crankshaft Front Oil Seal.	20-05-24		
Remove Camshaft	20-05-24		

W07;;2000 A 120485

CONTENTS — Continued

	Page		Page
GROUP 15—CRANKSHAFT, MAIN BEARING AND FLYWHEEL		GROUP 25—COOLING SYSTEM	
Special Tools	20-15-01	Water Pump Specifications	20-25-01
Crankshaft and Main Bearing Specifications	20-15-01	Thermostat Specifications	20-25-01
Flywheel and Flywheel Housing Specifications	20-15-03	Remove Water Pump	20-25-02
Crankshaft Pulley Specifications	20-15-03	Disassemble Water Pump	20-25-02
Measure Crankshaft End Play	20-15-03	Repair to Water Pump	20-25-02
Measure Main Bearing Clearance	20-15-04	Assemble Water Pump	20-25-03
Remove Crankshaft and Main Bearing	20-15-04	Install Water Pump	20-25-04
Measure Crankshaft	20-15-05	Remove Thermostat	20-25-05
Replacing Crankshaft Gear	20-15-07	Install Thermostat	20-25-05
Remove Crankshaft Rear Wear Ring	20-15-07		
Install Crankshaft and Main Bearings	20-15-07		
Remove Crankshaft Rear Oil Seal and Wear Ring	20-15-09		
Install Crankshaft Rear Oil Seal and Wear Ring	20-15-10		
Remove Flywheel Ring Gear	20-15-11		
Install Flywheel and Flywheel Housing	20-15-12		
 GROUP 20—LUBRICATION SYSTEM			
Essential Tools	20-20-01		
Oiling System Specifications	20-20-01		
Oil Cooler Specifications	20-20-03		
Remove and Install Oil Filter	20-20-03		
Remove and Install Oil Cooler	20-20-03		
Remove Oil Filter Nipple	20-20-04		
Install Oil Filter Nipple	20-20-04		
Remove and Install Dipstick Nipple	20-20-05		
Remove and Install Oil Pan	20-20-05		
Remove and Install Oil Bypass Valve	20-20-06		
Remove and Install Oil Pressure Regulating Valve and Seat	20-20-07		
Remove Oil Pan and Oil Pump	20-20-08		
Measure Oil Pump Parts	20-20-09		
Install Oil Pump and Oil Pan	20-20-10		

W07;;2000 B 010485

SPECIAL TOOLS

NOTE: Order tools from your SERVICE-GARD® Catalog, unless otherwise indicated.

Number	Name	Use
T26509	Lift Bracket	Engine removal and installation
T26508	Lift Bracket	Engine removal and installation

W07;;2001 A 030185

TORQUES

Engine Support Bolts 210 N·m (155 lb-ft)
Manifold Exhaust Locknut 5/16-in.

W07;;2001 B 060685

Most service procedures on the engine can be accomplished with the engine in the windrower. If the crankshaft is to be removed or engine overhauled, remove the engine as follows.

IMPORTANT: Be certain to plug all openings and cap all holes or lines that are disconnected to prevent contamination of a particular system.

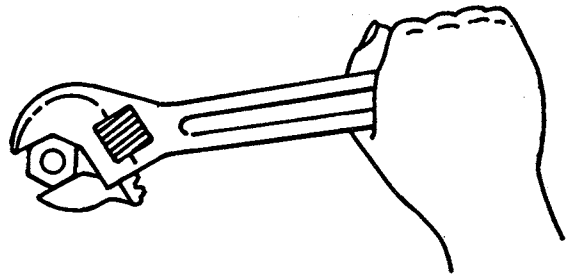

2MA;W9786 W07;;2505 C 191284

REMOVE ENGINE

If windrower is equipped with platform, remove it.

1. Open rear shielding.

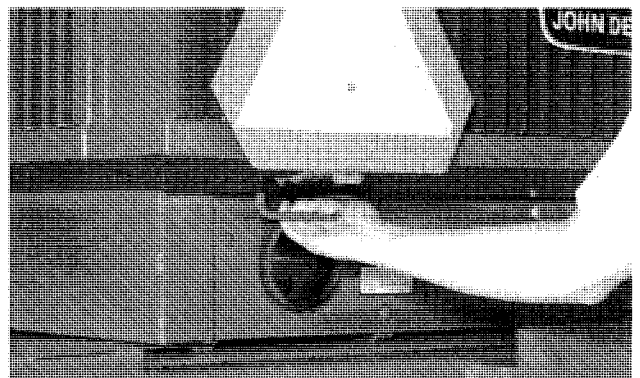

2MA;W9717 W07;;2505 D 120485

Engine Removal and Installation

2. Remove flanged nut (A) and detach stop cable (B) from windrower.

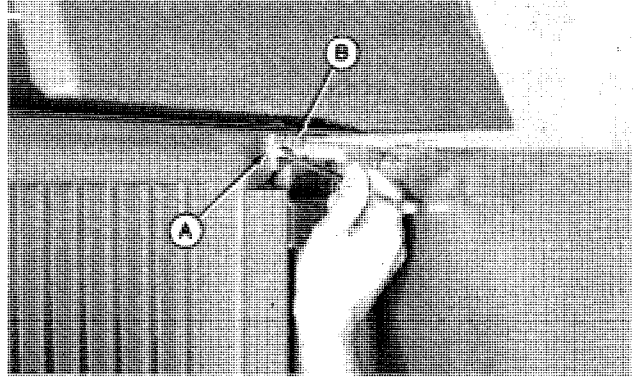

2MA;W10414 W07;;2505 E 191284

3. While supporting rear panel, remove cap screw and hinge bracket (A).

Let rear panel drop downwards from hinge pin (B) and remove from windrower.

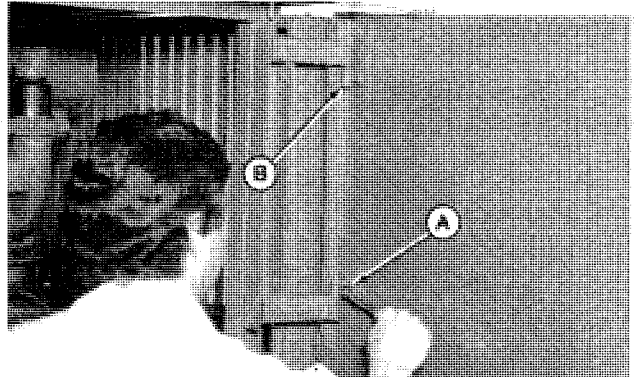

2MA;W10415 W07;;2505 F 191284

4. Support hinged hood and remove four flanged nuts (A). Remove hood from windrower.

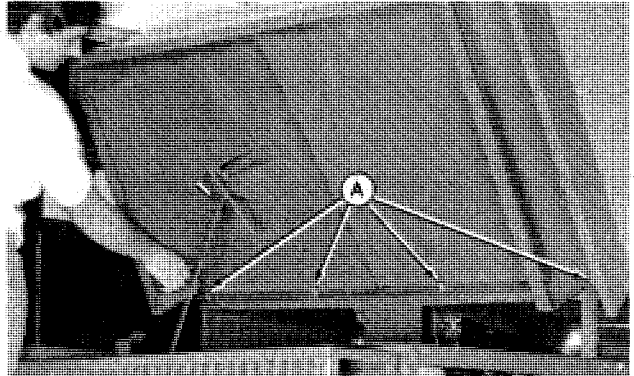

2MA;W10416 W07;;2505 G 191284

5. Loosen clamp and separate canister hose from manifold.

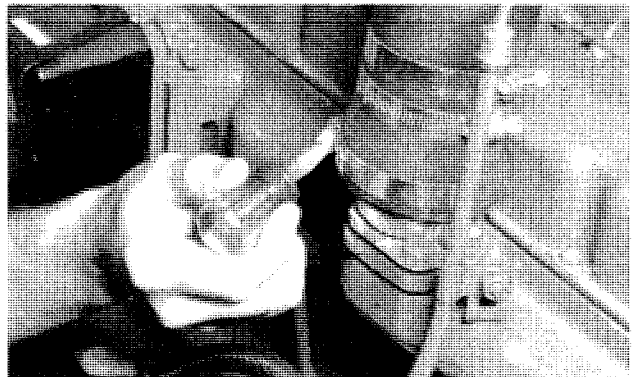

2MA;W10436 W07;;2001 C 030185

Engine Removal and Installation

6. If windrower is equipped with optional aspirated air cleaner, disconnect hose (A) from muffler or air cleaner.

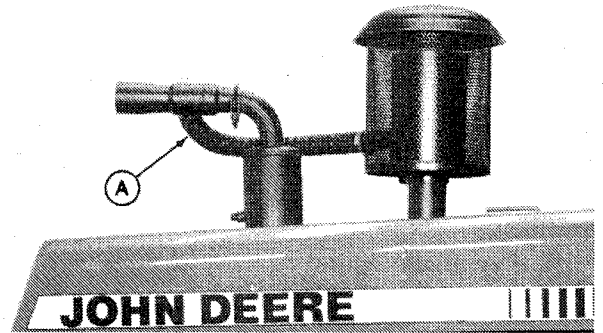

2MA;W10485 W07;;2001 D 030185

7. Loosen muffler clamp and remove muffler from exhaust manifold.

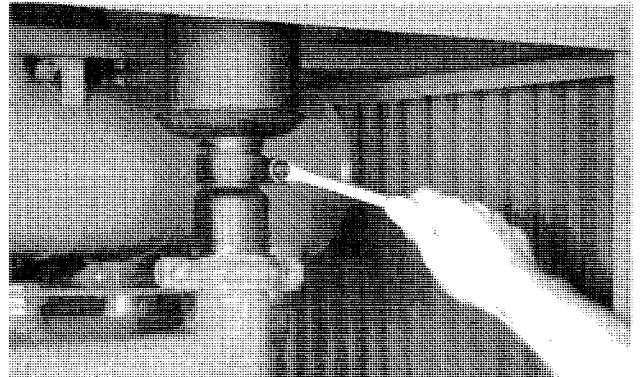

2MA;W10437 W07;;2001 E 030185

8. Remove four nuts (A) from underside of stationary hood.

NOTE: Leave bolts in position until stationary hood is removed.

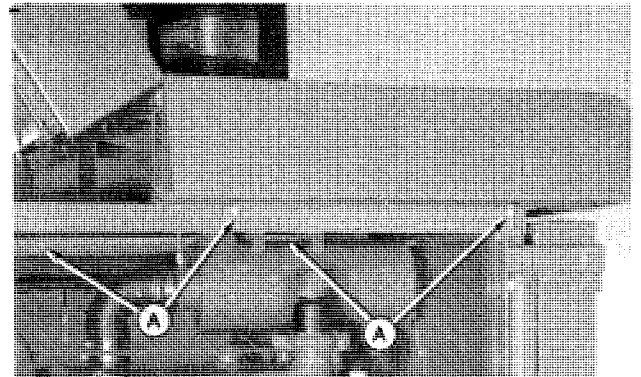

2MA;W10417 W07;;2505 J 191284

9. Open right side panel and support it. Remove two fasteners (A) from valve support bracket.

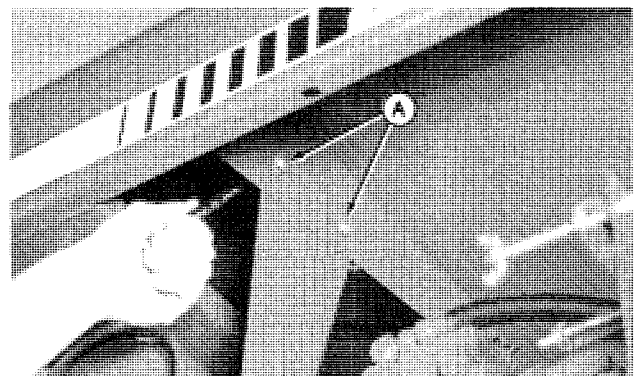

2MA;W10418 W07;;2505 K 191284

Engine Removal and Installation

10. Push up on stationary hood (A) until it clears hinge pin (B) on side panel (C).

Remove side panel and then stationary hood.

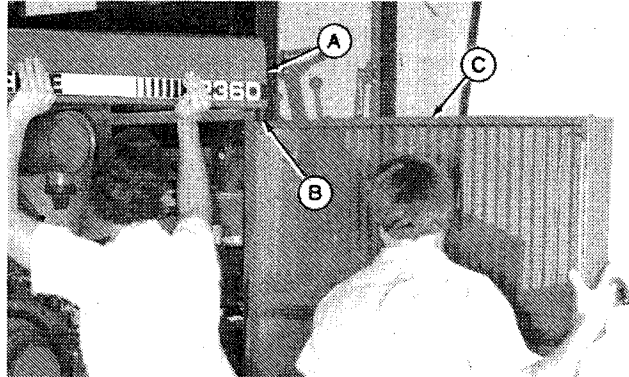

2MA;W10419 W07;;2505 L 191284

11. Disconnect negative (-) ground cable (A) from battery.

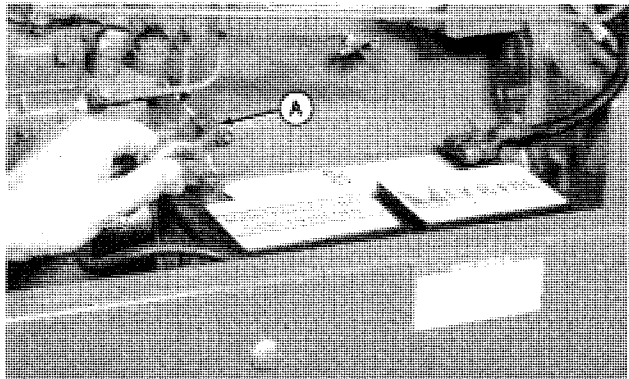

2MA;W9686 W07;;2001 F 030185

12. Disconnect temperature gauge wire from sending unit.

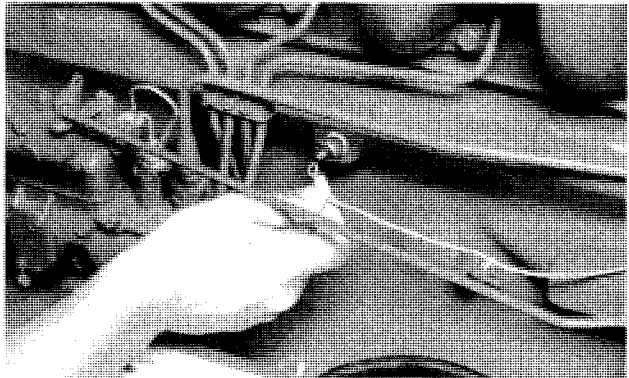

2MA;W10439 W07;;2001 G 030185

13. Disconnect working light wire (A) and red taillight wire (B).

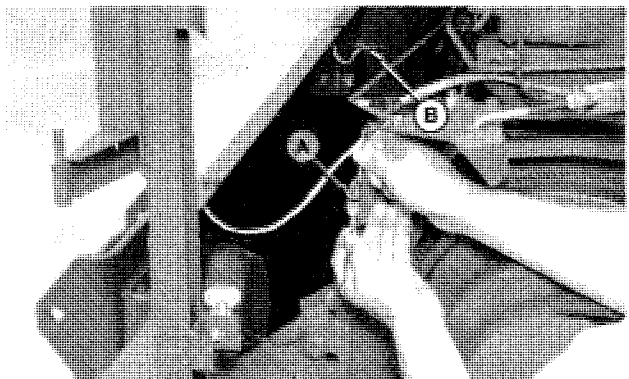

2MA;W10411 W07;;2505 O 191284

Engine Removal and Installation

14. Disconnect electric fuel shutoff cable (A) from fuel pump.

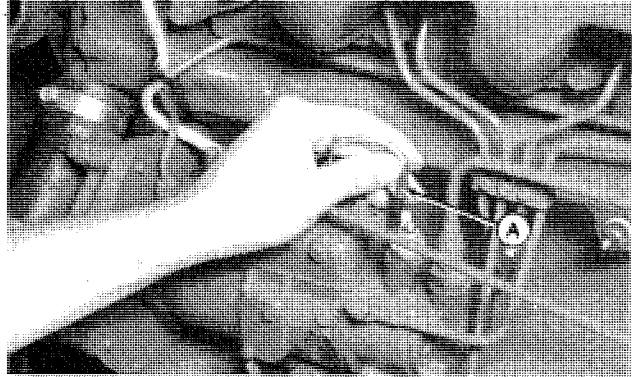

2MA;W10383 W07;;2001 H 030185

15. Remove 1/2-in. bolt, lock washer, and main circuit breaker from engine.

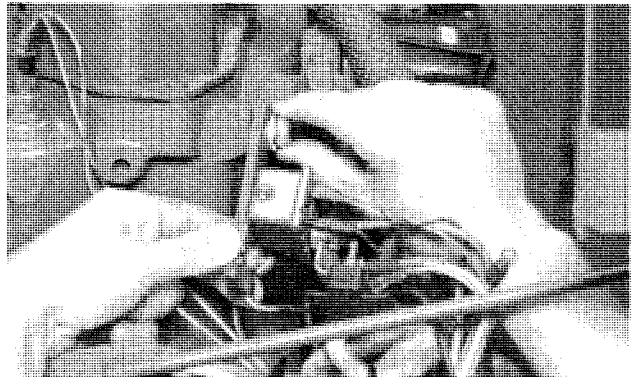

2MA;W10441 W07;;2001 I 030185

16. Remove temperature buzzer wire from engine switch.

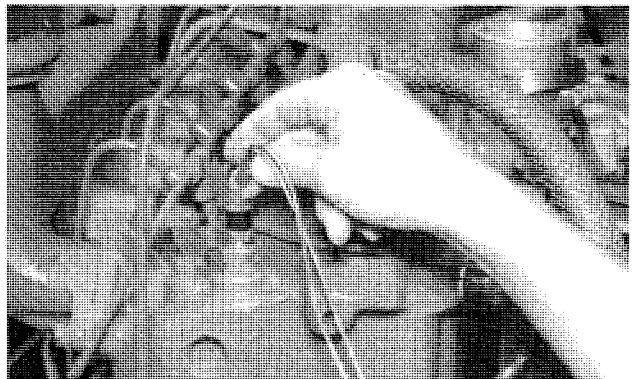

2MA;W10443 W07;;2001 J 030185

17. Remove oil pressure buzzer wire from sending unit.

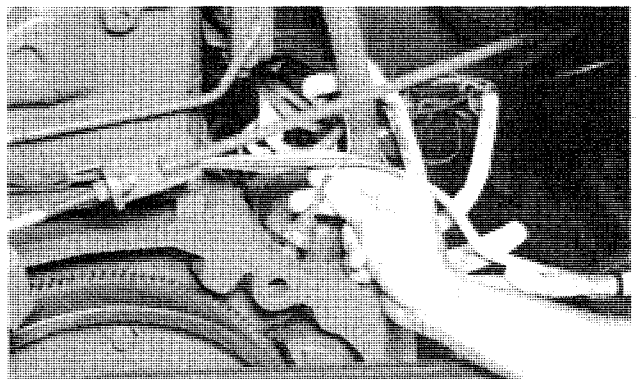

2MA;W10444 W07;;2001 K 030185

Engine Removal and Installation

18. Remove nut, washer, plastic shield, and positive (+) battery cables from starter solenoid.

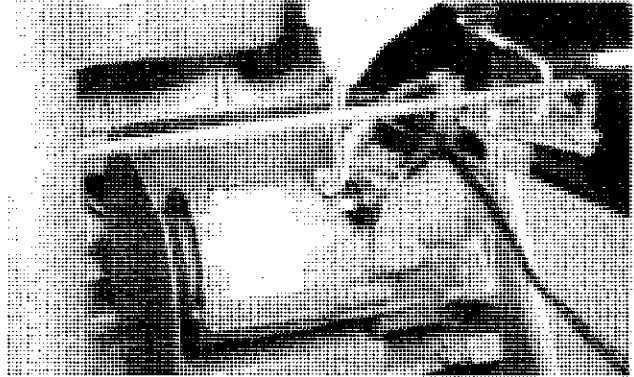

2MA;W10602 W07;;2001 L 030185

19. Remove nut and negative (-) wire from starter solenoid.

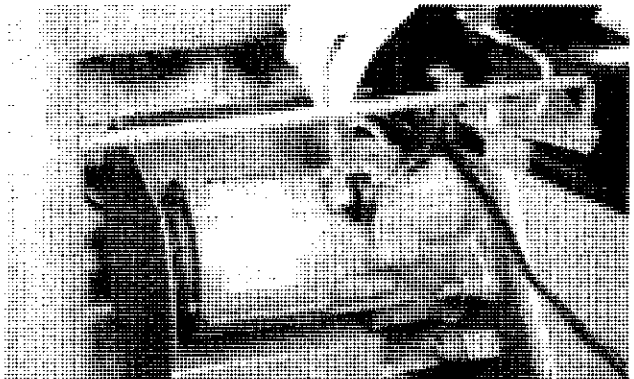

2MA;W10654 W07;;2001 M 030185

20. Disconnect wires from voltage regulator (A), alternator (B), and A-C compressor (C).

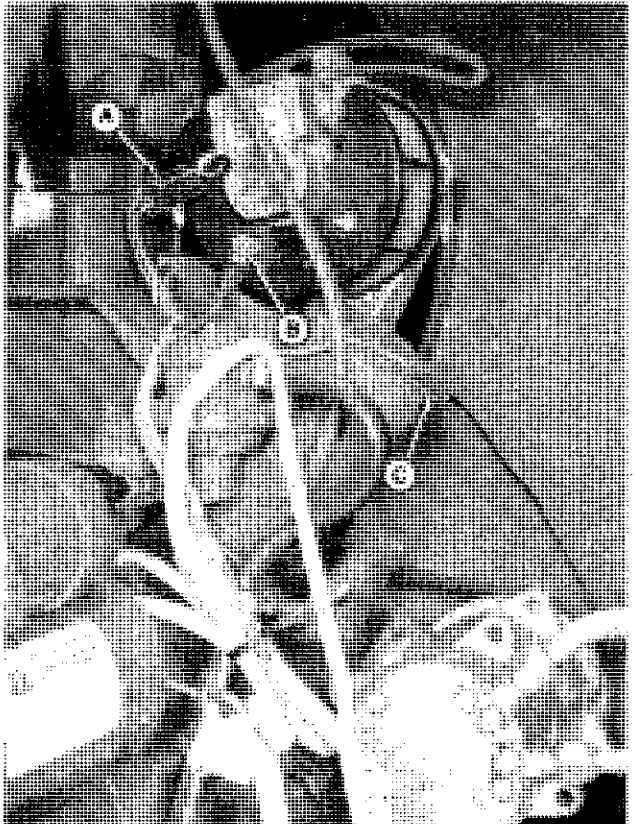

2MA;W10446 W07;;2001 N 030185

**Thank you very much for
your reading. Please Click
Here. Then Get COMPLETE
MANUAL. NO WAITING**



NOTE:

**If there is no response to
click on the link above,
please download the PDF
document first and then
click on it.**

Engine Removal and Installation

21. Remove belt tensioning hardware (A) and pivot hardware (B).

Remove compressor from support and drive belt. Secure to windrower frame clear of engine compartment.

IMPORTANT: Be sure not to disconnect, kink, or damage refrigerant hoses when repositioning compressor.

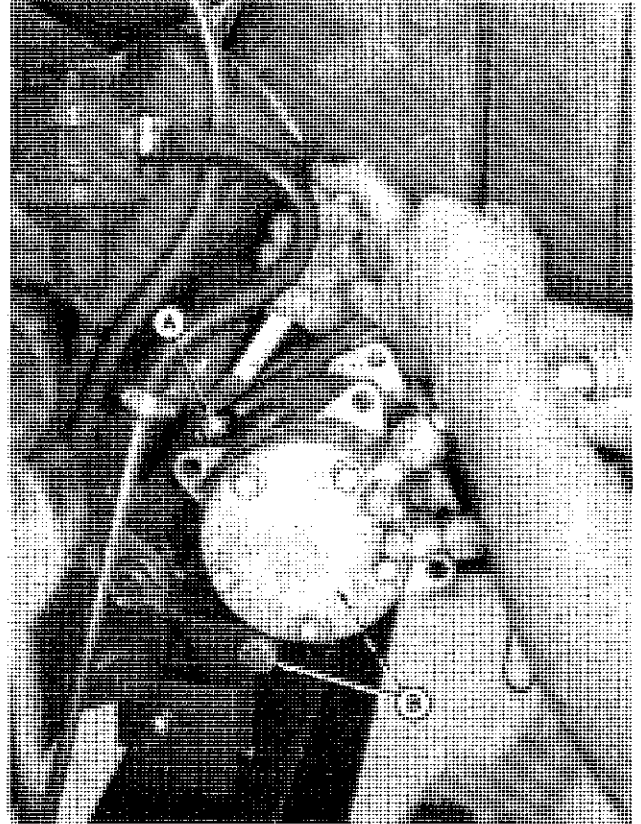

2MA;W10447 W07;;2001 Q 030185

22. Remove platform drive belt (A) from engine flywheel (B).

NOTE: Platform drive must be disengaged.

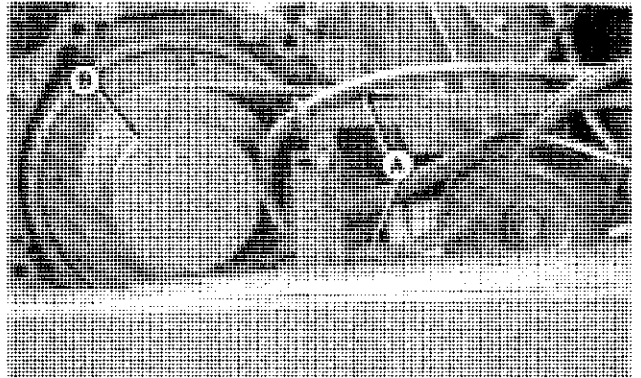

2MA;W10423 W07;;2001 P 120485

23. Loosen adjusting nuts (A) on tractor drive belt tensioner until belt will clear engine flywheel.

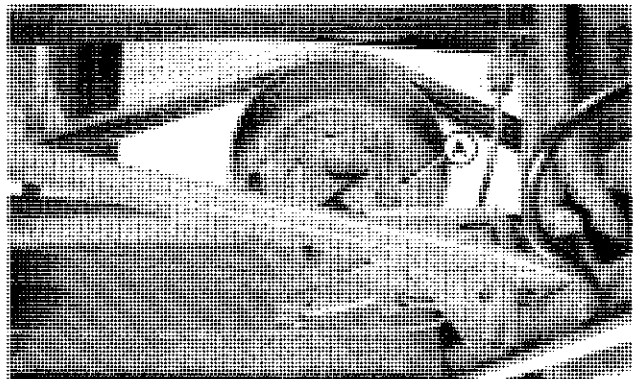

2MA;W10422 W07;;2001 Q 030185

Engine Removal and Installation

24. Remove tractor drive belt (A) from engine flywheel (B).

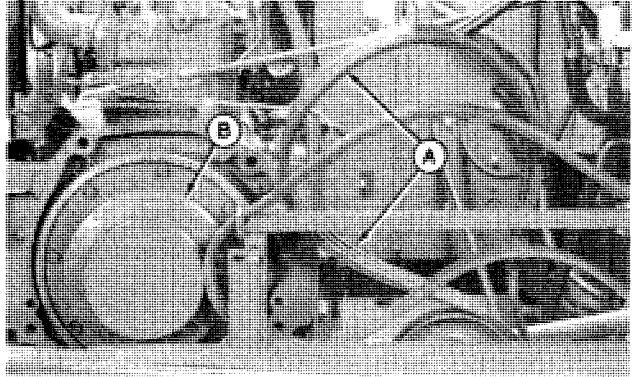

2MA;W10424 W07;;2001 R 030185

25. Remove cotter pin (A) and disconnect throttle linkage (B) from pivot plate (C).

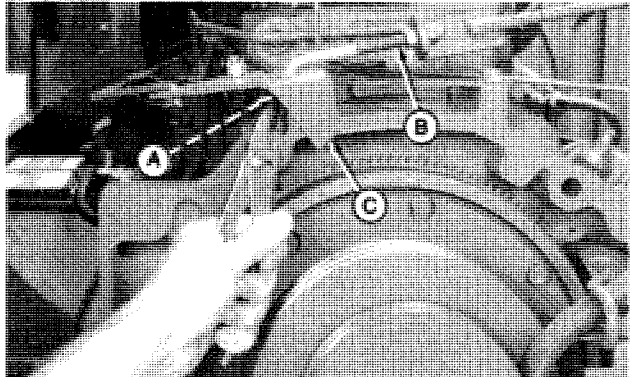

2MA;W10448 W07;;2001 S 030185

26. Drain engine coolant from radiator by opening drain valve (A).

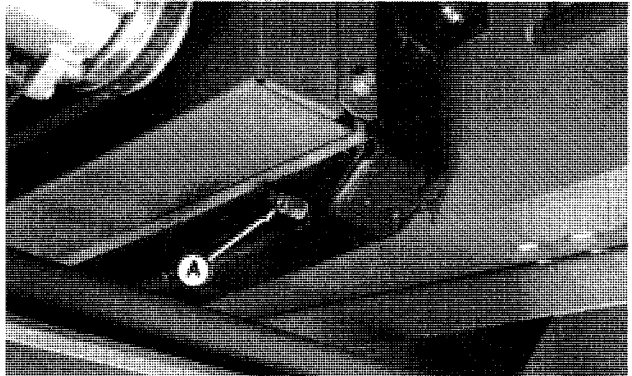

2MA;W10449 W07;;2001 T 030185

27. Loosen clamp and disconnect coolant return hose from radiator.



2MA;W10450 W07;;2001 U 030185

Engine Removal and Installation

28. Loosen clamp and remove coolant supply hose from water pump.

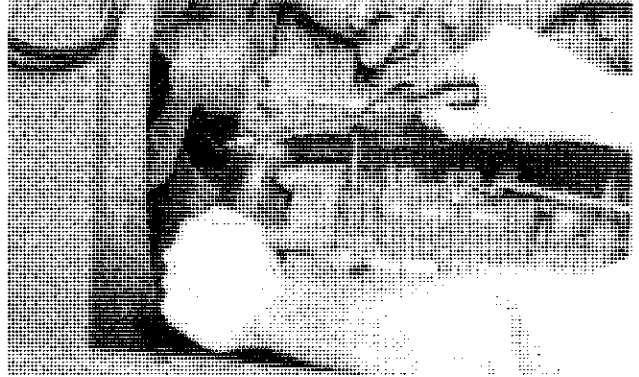

2MA;W10429 W07;;2001 V 030185

29. Loosen clamps (A) and remove heater hoses (B).

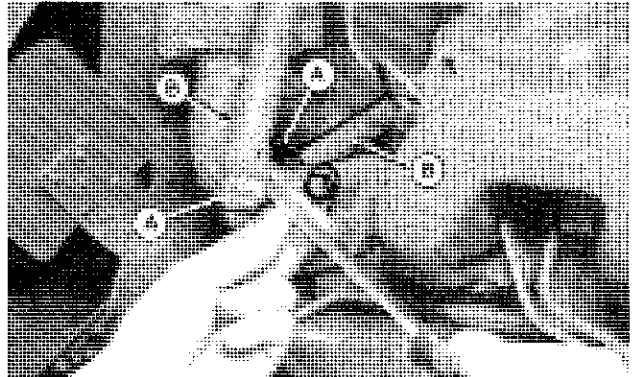

2MA;W10451 W07;;2001 W 030185

30. Remove fasteners (A) and strap (B) from fan shroud. Repeat steps on other side and separate fan shroud from radiator. Support shroud on fan.

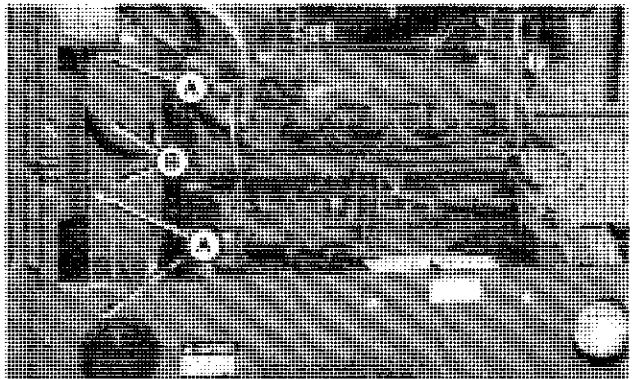

2MA;W10452 W07;;2001 X 030185

31. Disconnect engine negative (-) ground cable from frame.

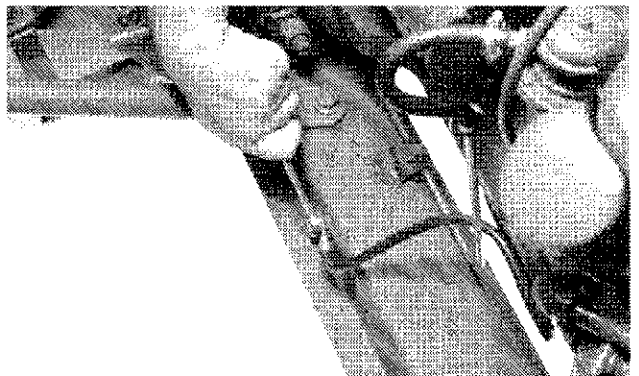

2MA;W10454 W07;;2001 Y 030185