



8850 Tractor



JOHN DEERE

TECHNICAL MANUAL 8850 Tractor

TM1254 (01FEB85) English

John Deere Waterloo Works
TM1254 (01FEB85)

LITHO IN U.S.A.
ENGLISH



8850 TRACTOR TECHNICAL MANUAL TM-1254 (FEB-85)

CONTENTS—REPAIR SECTIONS

SECTION 10—GENERAL

- Group 00—Specification and Special Tools
- Group 05—Predelivery, Delivery and After-Sale Services
- Group 10—Tune-up
- Group 15—Lubrication

SECTION 15—SEPARATION

- Group 00—Specifications and Special Tools
- Group 05—Front Drive
- Group 10—Fuel Tanks and Fenders
- Group 15—Front End
- Group 20—Front End and Engine From Clutch Housing
- Group 25—Engine
- Group 30—SOUND-GARD® Body
- Group 35—Front Hinge From Rear Hinge
- Group 40—Front Hinge
- Group 45—Clutch Housing
- Group 50—Rear Hinge
- Group 55—Torque Divider
- Group 60—Transmission
- Group 65—Final Drives

SECTION 25—ENGINE REPAIR

- Group 00—Specifications and Special Tools
- Group 05—Acquire Access to Cylinder Head, Valves and Camshaft
- Group 10—Cylinder Head, Valves and Camshaft
- Group 15—Acquire Access to Block, Liners, Pistons and Rods

- Group 20—Cylinder Block, Liners, Pistons and Rods
- Group 25—Acquire Access to Crankshaft, Main Bearings and Flywheel
- Group 30—Crankshaft, Main Bearings and Flywheel
- Group 35—Acquire Access to Lubrication System
- Group 40—Lubrication System
- Group 45—Acquire Access to Cooling System
- Group 50—Cooling System

SECTION 30—FUEL AND AIR SYSTEM REPAIR

- Group 00—Specifications and Special Tools
- Group 05—Acquire Access to Air Intake System
- Group 10—Air Intake System
- Group 15—Acquire Access to Diesel Fuel System
- Group 20—Diesel Fuel System
- Group 25—Speed Control Linkage

SECTION 40—ELECTRICAL REPAIR

- Group 00—Specifications and Special Tools
- Group 05—Harness Replacement
- Group 06—Connector Repair
- Group 10—John Deere Charging Circuit
- Group 15—Starter Circuit Repair
- Group 21—DELCO-REMY Starting Motor
- Group 25—Lighting Circuits
- Group 30—INVESTIGATOR™ II Warning System and Digital Tach. Repair
- Group 35—Accessory Circuits

Continued on next page

All information, illustrations and specifications contained in this technical manual are based on the latest information available at the time of publication. The right is reserved to make changes at any time without notice.

COPYRIGHT® 1985
DEERE & COMPANY
Moline, Illinois
All rights reserved
A JOHN DEERE ILLUSTRATION
Previous Edition
Copyright © 1984
Copyright © 1982
Copyright © 1981
DEERE & COMPANY

U10;0106EN AX2 040385

CONTENT—CONTINUED**SECTION 50—POWER TRAIN REPAIR**

- Group 00—Specifications and Special Tools
- Group 05—Remove/Install Clutch Oil Pressure Valve Housing
- Group 10—Clutch Oil Pressure Regulating Valve Housing
- Group 15—Clutch Operating Piston Housing
- Group 20—PERMA CLUTCH™
- Group 25—QUAD-RANGE™ Planetary
- Group 30—Independent PTO
- Group 35—Torque Divider and Drive Shafts
- Group 40—QUAD-RANGE™ Transmission
- Group 45—Shift Lever Assembly
- Group 50—Front Differential
- Group 55—Rear Differential Housing
- Group 60—Differential Lock Valves
- Group 65—Final Drives
- Group 70—Transmission Oil Filter Relief Valve Housing
- Group 75—Transmission Oil Cooler and Thermal Relief Valve

SECTION 60—STEERING/BRAKES REPAIR

- Group 00—Specifications and Special Tools
- Group 05—Remove/Install Power Steering Components
- Group 10—Steering Column
- Group 15—Metering Pump
- Group 20—Steering Valve
- Group 25—Steering and Feedback Cylinders
- Group 30—Remove/Install Brake Valve and Brake Accumulator
- Group 35—Brake Valve
- Group 40—Brake Accumulator
- Group 45—Bleeding Brakes and Testing Brake Assembly
- Group 50—Brake Pistons, Plates, and Disks

SECTION 70—HYDRAULIC REPAIR

- Group 00—Specifications and Special Tools
- Group 05—Charge Pump Assembly
- Group 10—Remove/Install Main Hydraulic Pump
- Group 15—Main Hydraulic Pump

- Group 20—Remove/Install Charge Circuit Valves and Attenuator

- Group 25—Charge Pump Control Valve
- Group 30—Hydraulic Filter Relief Valve Housing
- Group 35—Remove/Install HYDRA-CUSHIONED™ Seat Valve Assembly and Accumulator
- Group 40—Seat Valve Assembly
- Group 45—Remove and Install Pressure Control Valve
- Group 50—Pressure Control Valve
- Group 55—Remove/Install Rockshaft Components
- Group 60—Rockshaft Components
- Group 65—Lift Assist Cylinders
- Group 70—Draft Sensing Cylinders
- Group 75—Hitch Components
- Group 80—Remove/Install Selective Control Valves and Controls
- Group 85—Selective Control Valve and Coupler
- Group 90—Remote Cylinder
- Group 95—Transmission-Hydraulic System Clean-up Procedure

SECTION 80—MISCELLANEOUS REPAIR

- Group 00—Specifications and Special Tools
- Group 05—Wheels
- Group 10—Hinge Pins
- Group 15—Front Weight

SECTION 90—OPERATOR STATION REPAIR

- Group 00—Specifications and Special Tools
- Group 05—Air Conditioning System
- Group 06—Air Conditioning System Service
- Group 10—Heating System
- Group 15—HYDRACUSHIONED Seat
- Group 20—Miscellaneous Components

SECTION 95—MISCELLANEOUS OPTIONS

- Group 00—Specifications and Special Tools
- Group 60—Auxiliary Steering System
- Group 61—Auxiliary Brakes System
- Group 62—Auxiliary Trailer Brake

Introduction and Safety Information

INTRODUCTION

This technical manual is part of a twin concept of service.

FOS Manuals - for reference

Technical Manuals - for actual service

The two kinds of manuals work as a team to give you both the general background and technical details of shop service.

Fundamentals of Service (FOS) Manuals cover basic theory of operation, fundamentals of troubleshooting, general maintenance, and basic types of failures and their causes. They are for training new personnel and for reference by experienced technicians.

Technical Manuals are concise service guides for specific machines. They are on-the-job guides containing the information needed by the service technician.

There are two technical manuals covering these machines:

- The repair manual, identified by green section tabs, and
- The operation and test manual, identified by yellow section tabs. These sections correspond respectively to the 2-digit repair sections.

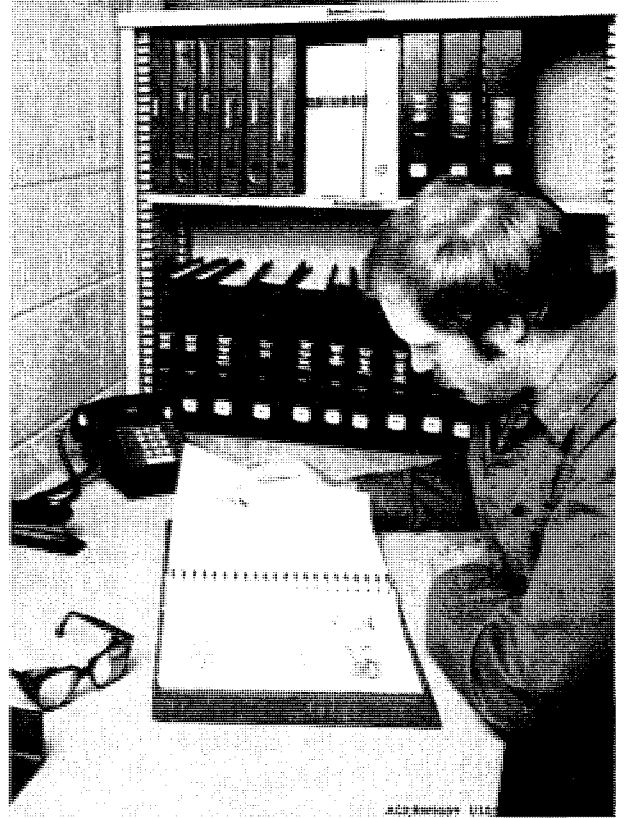

FEATURES OF THIS TECHNICAL MANUAL

- John Deere ILLUSTRATION format emphasizing more detailed pictures and fewer words.
- Instructions and illustrations grouped together in easy-to-use modules.
- Removal and Installation groups preceding some repair groups. These groups show how to remove and install components from the machine rather than from major components. They also show how to acquire access to major components of a machine.
- A section showing how to separate the tractor.

This technical manual was planned and written for you—an experienced service technician. Keep it in the shop where it is handy. Refer to it when you need to know correct service procedures or specifications.

Using the technical manual as a guide will reduce error and costly delay. It will also assure you the best in finished service work.

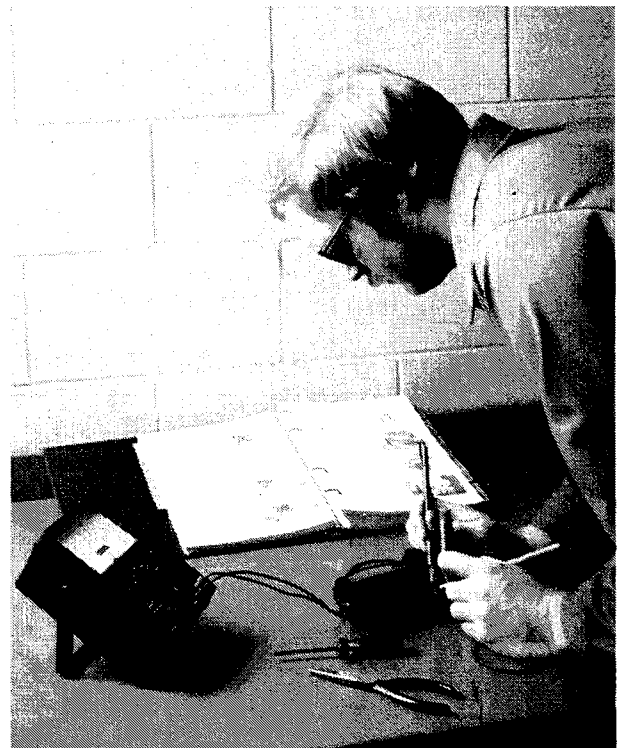

AC3;RW5560 U10;010INT B 101281

SAFETY MESSAGES



This safety alert symbol and word **CAUTION** identifies important safety messages in this manual and on tractor. When you see this symbol, be alert to the possibility of personal injury and carefully read message that follows.

U10:0101NT C 101281

IMPORTANT

The **IMPORTANT** message identifies potential problems which may cause consequential damage to tractor. Following recommended procedure will instruct technician how to avoid problem.

U10:0101NT D 101281

NOTES

The word *NOTE* is followed by a statement that identifies a qualification or exception to a previous statement. A "NOTE" may also identify nice-to-know information pertinent to, but not directly related to previous statement.

U10:0101NT E 101281

STAY CLEAR OF MOVING TRACTOR

Be sure everyone is clear of tractor and attached equipment before starting engine or moving steering wheel. Tractor and equipment move (A), even with transmission in PARK. Some steering movement often occurs as engine starts.

Never try to get on or off a moving tractor.

Before dismounting, place the transmission in PARK and lower implements to the ground. If tractor is to be left unattended, stop the engine and remove the key.

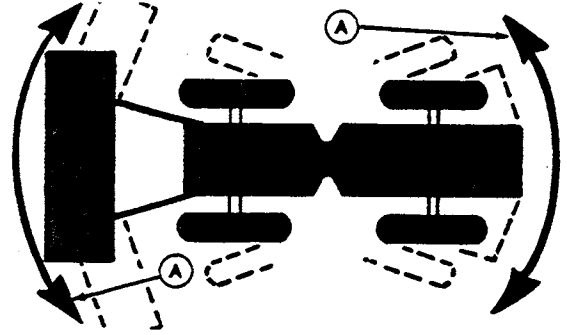

AC3;RW8078 U10;010INT F 250285

PREVENT MACHINE RUNAWAY

Avoid possible injury or death from machinery runaway.

Do not start engine by shorting across starter terminals. Machine will start in gear if normal circuitry is by passed.

NEVER start engine while standing on ground. Start engine only from operator's seat, with transmission in neutral or park.



AB6;TS177 U01;BYPAS1 040385

TRANSPORT TRACTOR SAFELY

Before descending a steep hill (A), shift to a low gear (B) to control the tractor with little or no braking. Never coast downhill.

When transporting on icy or graveled surfaces, be alert for skids which could result in loss of steering control. To decrease chance of skids, reduce speed and be sure tractor is properly ballasted.

Never tow tractor faster than 8 km/h (5 mph) with all wheels on the ground. With rear wheels raised, never tow tractor faster than 16 km/h (10 mph).

Use of radial ply tires require special precautions, see Operator Manual.

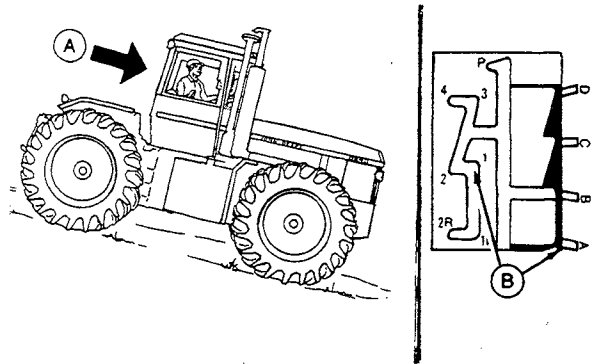

AC3;RW4421 U10;010INT G 030484

USE A SAFETY CHAIN

A safety chain will help control drawn equipment (B) should it accidentally separate from the drawbar (A) while transporting. Using the appropriate adapter parts, attach the chain to the tractor drawbar support or other specified anchor location. Provide only enough slack in the chain to permit turning. See your John Deere dealer for a chain with a strength rating equal to or greater than the gross weight of the towed machine.

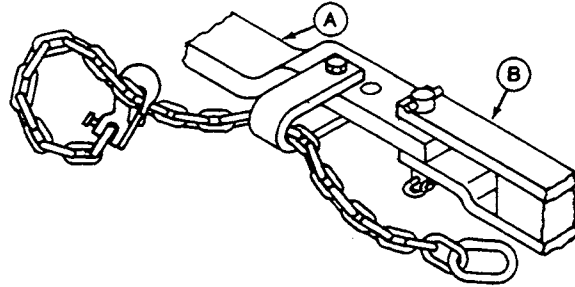

AB6;TS163 053;CHAIN 310884

TOW EQUIPMENT PROPERLY

Use caution when towing loads at transport speeds. Reduce speed if towed load weighs more than the tractor and is not equipped with brakes. Avoid hard braking applications. (Consult implement operator's manual for recommended transport speeds.)

Use additional caution when transporting towed loads under adverse surface conditions, when turning, or on inclines.

U01;TOW 061284

USE ADEQUATE SERVICE FACILITIES

Keep the service area clean and dry. Wet or oily floors are slippery. Wet spots can be dangerous when working with electrical equipment.

Make sure the service area is adequately vented.

Periodically check the shop exhaust system for leakage. Engine exhaust gas is dangerous.

Be sure all electrical outlets and tools are properly grounded.

Use adequate light for the job at hand.

Use lifting equipment and safety stands which have adequate strength for the job being performed.

Wear fairly tight clothing.

Know where the first aid kit and fire extinguishers are located, and know how to use them.

U10;010INT I 210183

SERVICE TRACTOR SAFELY

Do not service the tractor while it is in motion or while the engine is running.

Stay clear of hinge area when engine is running. Stop engine and remove key before working near hinge.

Drive shaft does not turn at engine start-up until clutch pedal is depressed and released. Be aware of sudden rotation of drive shaft as clutch is actuated.

Install lock bars (A) on tractor hinge before performing service work in hinge area. Be sure lock bars are removed before operating tractor.

Disconnect the battery ground cable before working on the electrical system or working in any area when you might accidentally contact electrical components. A short circuit could cause burns as well as damaging the electrical system.

Reinstall all shields removed during service.

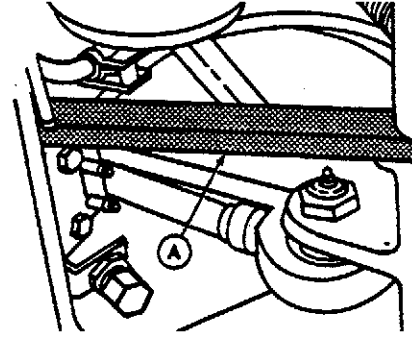

AC3;RW8506 U10;010INT AX2 2101B3

SERVICE TIRES SAFELY

Failure to follow proper procedures when mounting a tire on a wheel or rim can produce an explosion which may result in serious injury or death. Do not attempt to mount a tire unless you have the proper equipment and experience to perform the job.

When sealing tire beads on rims, never exceed 240 kPa (2.4 bar) (35 psi) or maximum inflation pressures specified by tire manufacturers for mounting tires. Inflation beyond this maximum pressure may break the bead, or even the rim, with dangerous explosive force. If both beads are not seated when the maximum recommended pressure is reached, deflate, reposition tire, relubricate bead, and reinflate.

Detailed agricultural tire mounting instructions, including necessary safety precautions, are contained in John Deere Fundamentals of Service (FOS) Manual 55. Such information is also available from the Rubber Manufacturers Association and from tire manufacturers.

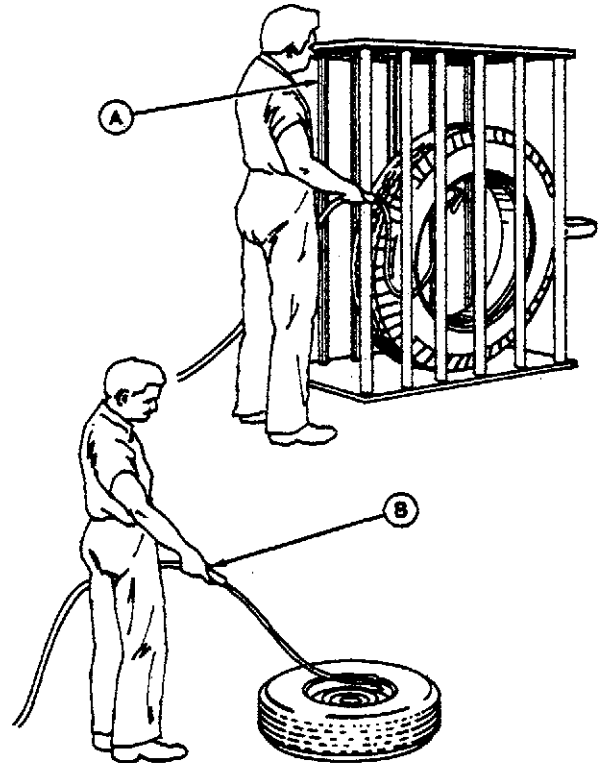

AC3;TS0123 U10;010INT L 0304B4

DO NOT MODIFY TRACTOR

Unauthorized modification to the machine may impair the function and/or safety and affect machine life.

Never modify structural members of SOUND-GARD body (A) by welding, bending, drilling or cutting as this might weaken the structure. If any structural member is damaged, replace the entire structure. Do not attempt repairs.

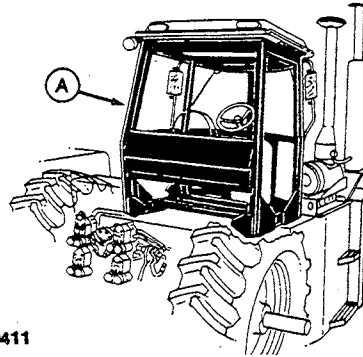

RW10411

AJ7;RW1041 1 U01;MODIFY 4WD 250585

KEEP ROPS INSTALLED PROPERLY

Make certain all parts are reinstalled correctly if the roll-over protective structure (ROPS) is loosened or removed for any reason. Tighten mounting bolts to proper torque.

The protection offered by ROPS will be impaired if ROPS is subjected to structural damage, is involved in an overturn incident, or is in any way altered. A damaged ROPS should be replaced, not reused.

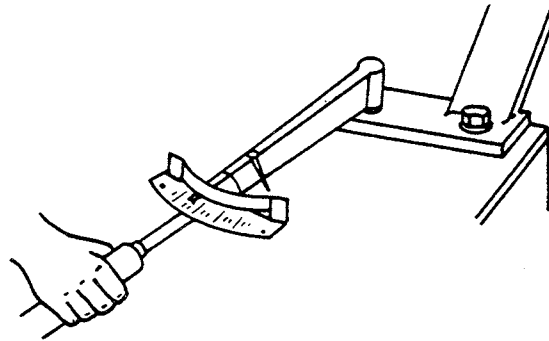

AB6;TS176 053;ROPS3 261184

OBSERVE ELECTRICAL SERVICE PRECAUTIONS

Keep all sparks and flames away from batteries, as gas given off by electrolyte is explosive. To avoid sparks, connect ground cable last and disconnect it first. When using a booster battery, follow instructions in Operator's Manual.

To avoid shocks and burns, disconnect battery ground cable before servicing any part of electrical system.

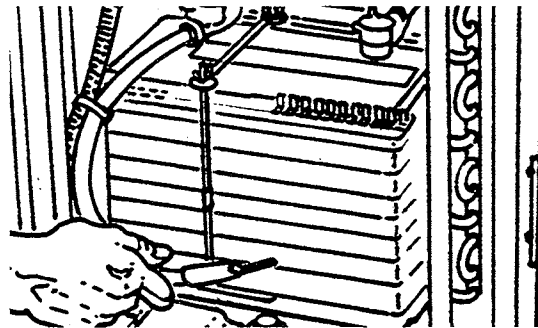

AC3;RW8074 U10;010INT BX2 061282

SERVICE COOLING SYSTEM SAFELY

If radiator cap (A) must be removed, do not remove it when engine is hot. Shut the engine off and wait until it cools. Then turn the cap to the first stop to relieve pressure before removing it completely.

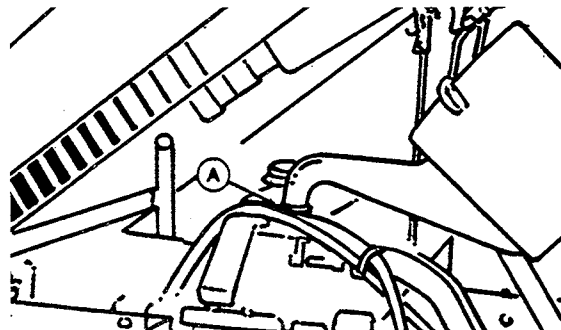

AC3;RW8076 U10;010INT SX2 061282

AVOID HIGH-PRESSURE FLUIDS

Escaping fluid under pressure can penetrate the skin causing serious injury. Relieve pressure before disconnecting hydraulic or other lines. Tighten all connections before applying pressure. Keep hands and body away from pinholes and nozzles which eject fluids under high pressure. Use a piece of cardboard or paper to search for leaks.

If ANY fluid is injected into the skin, it must be surgically removed within a few hours by a doctor familiar with this type injury or gangrene may result.

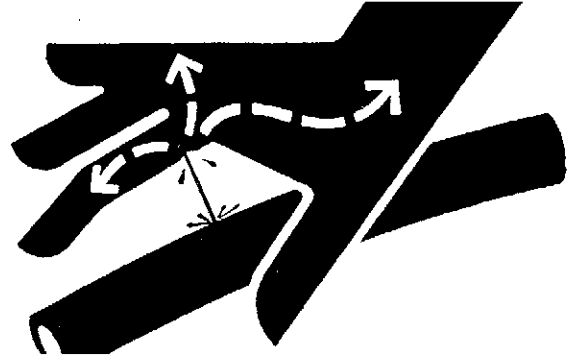

AB6;X9811 053;FLUID 100584

HANDLE CHEMICALS PROPERLY

SOUND-GARD body air filters (A) are not designed to filter out harmful chemicals. Follow instructions given in the implement operator's manual and those given by the chemical manufacturer when using agricultural chemicals.

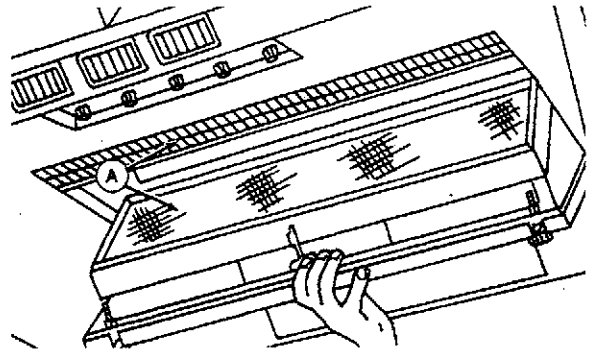

AJ7;RWS704L U01;HANDLE 2 311084

SERVICE BRAKE ACCUMULATOR SAFELY

Relieve all pressure from accumulator before disconnecting brake accumulator or brake valve. To do so open bleed screws and pump brake pedal with engine stopped, until pedal easily goes all way down.

The accumulator is charged with dry nitrogen to a pressure of 500 psi (3450 kPa) (35 bar). If it needs recharging, have job done only by a qualified service person and only with dry nitrogen.

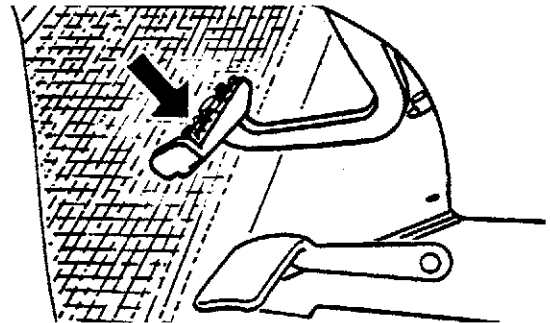

AC3;RW8103 U10;010INT FX1 220283

AVOID EXHAUST FUMES

Never run engine in a closed building. Make sure service area is adequately ventilated.

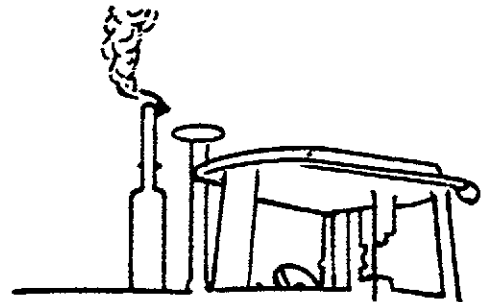

AJ7;RW8075 U01;FUMES 1 250285

AVOID EXPLOSIONS OR FIRE

Batteries produce explosive gas. Before using booster batteries, read instructions in operator's manual.

Before connecting or disconnecting battery charger, turn the charger off to avoid sparks. See instructions in operator's manual.

Be careful with starting fluid or any type fuel.

Never smoke while handling fuel.



AC3;RW5895 U10;AVOID FIRE 250285

PROTECT AGAINST NOISE

Prolonged exposure to loud noise can cause impairment or loss of hearing.

Wear a suitable hearing protective device such as earmuffs (A) or earplugs (B) to protect against objectionable or uncomfortable, loud noises.

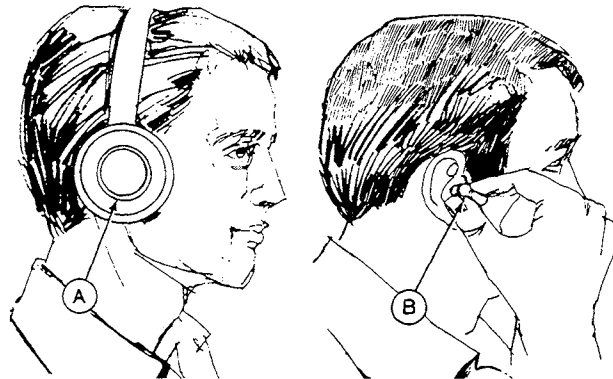

AC3;RW213 U10;010INT Q 100682

WEAR SAFETY EQUIPMENT

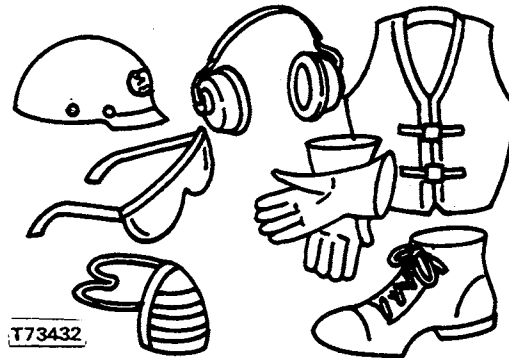

T73432

AC3;T73432 U10;SAFETY EQUIP 250285

Section 10 GENERAL

CONTENTS

GROUP 00 - SPECIFICATIONS AND SPECIAL TOOLS

General Tractor Specifications	10-00-01
Ground Speeds	10-00-02
Predelivery	10-00-02
Tune-up	10-00-03
Lubrication	10-00-03
English Torque Specifications	10-00-04
Metric Troque Specifications	10-00-04
Special Tools	10-00-05

GROUP 05 - PREDELIVERY, DELIVERY AND AFTER-SALE SERVICES

Dealer Predelivery Service	10-05-01
Charge Battery(ies) (If Needed)	10-05-01
If Equipped, Install Ether Aid Solenoid Wiring	10-05-02
Tighten Air Intake Hose Clamps	10-05-02
Adjust All Lamps	10-05-03
Aim Head Lamps	10-05-03
Remove SMV Plastic Cover	10-05-04
Check Tire Pressure	10-05-04
Adjust Wheel Spacing	10-05-04
Adjusting Front Fenders	10-05-04
Adjust Front Wheel Toe-In	10-05-04
On FWD: (If Equipped), Set Steering Stops	10-05-05
Torque Wheel Hardware To Specifications	10-05-05
Lubricate All Grease Fittings	10-05-05
Follow Break-In Procedure	10-05-05
Verify Factory Services	10-05-06
Is Engine Crankcase Oil Level Correct ..	10-05-06
Is Fuel Injection Sealing Cover (Or Pump Seals) Intact	10-05-06
Is Air Cleaner Element(s) Installed Correctly	10-05-06
Is Belt(s) Adjusted Correctly	10-05-07
Is Engine Coolant Level Correct	10-05-07
Is Transmission/Hydraulic System Oil Level Correct	10-05-07
Are Shields, Handrails, and Steps Installed Correctly	10-05-08

Is Clutch Pedal Adjusted Correctly	10-05-08
If 4WD, Are Safety Hinge Straps On Tractor	10-05-8
Was Battery(ies) Charged As Received From Factory	10-05-09
If Equipped, Does INVESTIGATOR™ II Warning System Operate Correctly ..	10-05-09
Are Instrument Panel Gauges And Lights Operating Correctly	10-05-09
Are All Lights Operating Correctly In All Positions	10-05-10
Is Neutral Start Switch Operating Correctly	10-05-10
Is Engine Fast And Slow Idle Adjusted Correctly	10-05-10
Does Engine Stop Knob Operate Correctly	10-05-10
Are Brakes Operating Correctly With Engine On/Off	10-05-11
Does Transmission Operate Correctly In All Gears (And In Park)	10-05-11
Does Hydraulic System Operate Properly	10-05-11
Does PTO Operate Correctly	10-05-12
Are Coolant Lines Free Of Leaks	10-05-12
Are Engine Oil Lines Free Of Leaks	10-05-12
Are Fuel Lines Free Of Leaks	10-05-12
Are Hydraulic/Transmission Lines Free Of Leaks	10-05-13
Are Seat Belts Installed And Operational, If Equipped	10-05-13
Are Decals Smooth And Neat	10-05-13
Is Paint Coverage Acceptable	10-05-13
Is Overall Tractor Appearance Acceptable	10-05-13
If Equipped, Does SGB Door Operate Properly	10-05-13
If Equipped, Is SGB Upholstery Neat In Appearance	10-05-13

Continued on next page

U10:010CON AX2 070263

CONTENTS—CONTINUED

**GROUP 05 - PREDELIVERY, DELIVERY AND
AFTER-SALE SERVICES - Cont.**

If Equipped, Is Interior of SGB	
Clean	10-05-14
Delivery Service	10-05-14
After Sale Inspection	10-05-15
Inspect Engine	10-05-16
Are There Any Oil, Fuel Or	
Coolant Leaks	10-05-16
Is Fan Belt Tension Correct	10-05-16
Are Engine Idle Speeds Correct	10-05-17
Does Fuel Shut-Off	
Operate Correctly	10-05-17
Is Throttle Lever Friction Disk	
Adjusted Correctly	10-05-17
Inspect Electrical System	10-05-17
Does Neutral Start Switch	
Operate Correctly	10-05-17
Do All Lights Operate Correctly	10-05-18
Does Air Conditioner Operate	
Correctly	10-05-18
Is Battery At Full Charge	10-05-19
Inspect Power Train	10-05-20
Is Transmission Operating In	
All Gears And In Park	10-05-20
Is Differential Lock Operating	
Correctly And Adjusted	
With Brake Pedal	10-05-20
Is PTO Operating Correctly And	
Are Shields In Place	10-05-20
Inspect Hydraulic System	10-05-21
Is Rockshaft Operating Correctly	10-05-21
Are There Any Visible Oil Leaks	10-05-21
Inspect Steering And Brakes	10-05-21
Do Brakes Operate Correctly	
With Engine On And Off	10-05-21
Does Steering Operate Correctly	
Both Left And Right	10-05-22
Inspect Operator Station	10-05-22
Are SGB Or ROPS Mounting	
Tight And Properly Installed	10-05-22
Is Seat Operating Correctly	10-05-23
Are All Gauges And Indicator	
Lights Operating Correctly	10-05-23
Are Following Fluid Levels Correct:	10-05-23
Engine Crankcase	10-05-23
Engine Coolant	10-05-24
Hydraulic System	10-05-24
Battery	10-05-24

Does Customer Understand	
Proper Operation and Maintenance	
Of Tractor	10-05-25

GROUP 10 - TUNE-UP

Preliminary Engine Tests	10-10-01
Remove and Inspect Air Cleaner	
Elements	10-10-01
Cleaning Element	10-10-03
Washing Element	10-10-03
Inspect Element	10-10-04
Tighten Air Intake Connections	10-10-04
Check Air Intake Vacuum	10-10-04
Clean Crankcase Vent Tube	10-10-05
Cooling System Components	10-10-06
Cleaning Grille Screens, Radiator and Oil	
Cooler	10-10-06
Yearly Cooling System Flush	10-10-07
Engine Cooler-Conditioner Filter	10-10-08
Test Radiator Cap	10-10-09
Checking Fan Belt Tension	10-10-10
Adjusting Fan Belt Tension	10-10-11
Adjusting Compressor or Alternator	
Belt Tension	10-10-11
Check Fuel Filters	10-10-11
Check Water Separator	10-10-11
Replace Water Separator Filter	10-10-12
Bleeding Fuel Lines	10-10-12
Check and Adjust Injection Pump	
Timing	10-10-12
Check and Adjust Slow and Fast Idle	
Speeds	10-10-14
Servicing Battery	10-10-15
Make Final Engine Test	10-10-15

GROUP 15 - LUBRICATION

Lubricate Tractor Properly	10-15-01
Engine Oil	10-15-01
Transmission - Hydraulic Oils	10-15-02
Grease	10-15-02
Use Approved Alternative Lubricants	10-15-03
Store Lubricants Correctly	10-15-03
Lubrication Services (Chart)	10-15-04
Check Engine Oil Level	10-15-05

Continued on next page

U10/010CON BX2 070283

CONTENTS—CONTINUED

GROUP 15 - LUBRICATION - Continued

Check Engine Oil and Oil Filter	10-15-05	Lubricate Steering Cylinder Rear	
Clean Crankcase Vent Tube	10-15-05	Pivot Pins	10-15-08
Check Transmission-Hydraulic Oil		Lubricate Steering Feedback Cylinder	
Level	10-15-06	Rear Pivot Pin	10-15-08
Replace Hydraulic Oil Filter	10-15-06	Lubricate Remote Grease Fittings	10-15-09
Change Transmission-Hydraulic Oil	10-15-06	Lubricate Wide Swing Drawbar	10-15-09
Clean Transmission-Hydraulic Oil		Lubricate Outer Bearing Supports	10-15-09
Filter Screens	10-15-07	Lubricate Lift Arms	10-15-09
Replace Transmission Oil Filter	10-15-07	Lubricate Center Link	10-15-10
Lubricate Axle Bearings	10-15-07	Lubricate Front Differential Rear Pivot ...	10-15-10
Lubricate Hinge Pins	10-15-08	Lubricate Front Differential Front	
Lubricate U-Joints	10-15-08	Pivot	10-15-10

SPECIFICATIONS AND SPECIAL TOOLS

GENERAL TRACTOR SPECIFICATIONS

ENGINE

Power (Factory observed PTO at 2100 rpm)	300 hp (224 kw)
Type	8-cylinder, V-8, dual valve in head, diesel, turbocharged and intercooled
Slow idle speed	800 rpm
Working speed range	1500 to 2100 rpm
Bore and stroke	5.51 X 5.00 in. (140 X 127 mm)
Displacement	955 cu. in. (15.6 L ³)
Compression ratio	14.2 to 1
Firing Order	1L-4R-2R-2L-3R-3L-4L-1R
Valve clearance	
Intake	0.016 in. (0.40 mm)
Exhaust	0.023 in. (0.060 mm)
Crosshead clearance	0.000 to 0.001 in. (0.000 to 0.025 mm)
Injection pump timing	TDC
Lubrication system	forced-feed, pressurized with full-flow and bypass filters

CAPACITIES

Fuel tank	240 U.S. gal. (908 L)
Cooling system	78 U.S. qts. (74 L)
Crankcase (with filter change)	51 U.S. qts. (48 L)
Transmission-hydraulic system	45.5 U.S. gal. (172.2 L)

TIRES AND TREADS See Section 80

GENERAL DIMENSIONS

Wheelbase	133 in. (3.38 m)
Overall length	258 in. (6.55 m)
Height to muffler cover*	157 in. (3.96 m)
Height to top of SOUND-GARD body*	129 in. (3.25 m)
Overall width	127.5 in. (3.24 m)
Width at roof	55 in. (1.38 m)
Turning radius	19 ft. (5.79 m)

SHIPPING WEIGHT** 36,074 lbs. (16,360 kg)

*Tractor equipped with 20.8 to 38 dual

**Equipped for average field service, without fuel and ballast

U10;010000 AXZ 070283

GROUND SPEEDS

Travel speeds are shown at right with 20.8-38 R-1 tires.
Adjust as follows for other tires:

Tire Size	Tread	Changes in Speeds
20.8-38	R-1	Base tire
20.8R-38	R-1	2.8% faster
20.8-38	R-2-0	1.4% faster
23.1-34	R-1	2.8% slower
23.1-34	R-2-0	2.0% faster
24.5-32	R-1	3.9% slower
24.5R-32	R-1	1.8% slower
24.5-32	R-2-0	Same as base tire
30.5L-32	R-1	1.0% slower
30.5L-32	R-1	0.5% slower
20.8-42	R-1	6.0% faster
20.8R-42	R-1	7.3% faster

NOTE: Speed listed should only be used for the speed the tractor is traveling at when using a specified gear.

* Ground speeds for tractors with transmission serial number TSGC1003096RX and up. Ground speeds in A, C, and D ranges are not affected by serial number change.

TRACTOR TRAVEL SPEEDS

Range	Gear	2100 Engine RPM	
		MPH	KM/H
A	1	2.08	3.35
	2	2.59	4.17
	3	3.76	6.05
	4	4.69	7.55
	1R	3.96	6.37
	2R	4.95	7.96
B	1	4.75	7.65
	2	5.70	9.17
	3	8.24	13.26
	4	10.29	16.56
	1R	8.76	14.10
	2R	10.94	17.60
C	1	5.53	8.90
	2	6.90	11.10
	3	9.99	16.07
	4	12.46	20.05
	1R	10.54	16.96
	2R	13.15	21.16
D	1	8.96	14.42
	2	11.18	17.99
	3	16.19	26.05
	4	20.20	33.50

U10;010000 BX2 040484

PREDELIVERY SPECIFICATIONS

Injection Pump Timing	TDC
Engine Speeds	
Slow Idle	800 rpm
Fast Idle	2300 rpm
Fast Idle at Full Load	2100 rpm
Clutch Pedal Height	5½ in. (140 mm)
Brake Pedal Free Travel	3 in. (8 mm)
Torques	
Wheel Sleeve Half-to-Wheel	300 ft-lbs. (407 N·m)
Rim Clamp-to-Wheel	170 ft-lbs. (230 N·m)
Outside Dual-to-Hub	300 ft-lbs. (407 N·m)
Air Intake Clamps	6 ft-lbs. (8.5 N·m)
Fan, Compressor, and Alternator Belt Tension	85-95 lbs. (380-425 N)

U10;010000 CX2 161181

TUNE-UP

Power (Factory Observed PTO at 2100 rpm)	300 hp (224 kw)
Compression	325 psi (2240 kPa) (22 bar)
Vacuum at 2100 rpm (clean air filters)	22-27 in. (5.47-6.72 (kPa)
Thermostat Opening Temperature	180°F (82°C)
Radiator Cap Pressure Release	14-17 psi (0.9-1.2 bar)
Engine Speeds	
Slow Idle	800 rpm
Fast Idle	2300 rpm
Fast Idle at Full Load	2100 rpm

U10;010000 DX2 061282

LUBRICATION

Engine Crankcase	50.7 U.S. qts. (48 L)
Transmission-Hydraulic System	45.5 U.S. gal. (172.2 L)
Service Intervals	
Check Engine Oil Level	10 Hours
Check Transmission-Hydraulic Oil Level	10 Hours
Change Engine Oil and Filters	200 Hours
Clean Engine Vent Tube	600 Hours
Change Hydraulic Oil Filter	600 Hours
Clean Filter Screens	1200 Hours
Change Transmission-Hydraulic Oil	1200 Hours
Change Transmission Filter	Annually or with indicator lamp
Lubricate Grease Fittings	
Hinge Pins	10 Hours
Steering Cylinder Pivot Pins	10 Hours
Feedback Cylinder Pivot Pins	10 Hours
U-joints and Slip Joints	10 Hours
Axle Bearings	10 Hours
Wide Swing Drawbar	10 Hours
Outer Shaft Bearing Supports	200 Hours
3-Point Hitch	200 Hours
Front Differential Pivots	600 Hours

U10;010000 EX2 070283

ENGLISH TORQUE SPECIFICATIONS

NOTE: Wrench torque tolerance is $\pm 20\%$.

Bolt Diameter	Plain Head*		Three Radial Dashes*		Six Radial Dashes*	
	lb-ft	N-m	lb-ft	N-m	lb-ft	N-m
1/4 in.	6	8	9	12	12	16
5/16 in.	10	14	18	24	25	34
3/8 in.	20	27	30	41	45	61
7/16 in.	30	41	50	68	70	95
1/2 in.	45	61	75	101	110	149
9/16	70	95	110	150	155	210
5/8 in.	95	128	155	210	215	290
3/4 in.	165	225	270	365	385	520
7/8 in.	170	230	435	590	620	840
1 in.	255	345	660	895	930	1260

Torque figures indicated above and in the Specification Sections of this manual are valid for non-greased or non-oiled threads and heads unless otherwise specified. Therefore, do not grease or oil bolts or cap screws unless otherwise specified in this manual.

* Torque value for bolts and cap screws are identified by their head markings.

U10;010000 FX2 250484

METRIC TORQUE SPECIFICATIONS

NOTE: Wrench torque tolerance is $\pm 20\%$.

Bolt Diameter	Property Class 8.8*		Property Class 10.9*	
	lb-ft	N-m	lb-ft	N-m
M5	5	6	7	9
M6	8	10	11	15
M8	18	25	27	37
M10	37	50	54	73
M12	64	87	96	130
M16	159	215	236	320
M20	321	435	458	620
M24	554	750	790	1070

Torque figures indicated above and in the Specification Sections of this manual are valid for non-greased or non-oiled threads and heads unless otherwise specified. Therefore, do not grease or oil bolts or cap screws unless otherwise specified in this manual.

* Torque value for bolts and cap screws are identified by their property class head markings.

U10;010000 GX2 250484

Thank you very much for your reading. Please Click Here. Then Get COMPLETE MANUAL. NO WAITING



NOTE:

If there is no response to click on the link above, please download the PDF document first and then click on it.

SPECIAL TOOLS

NOTE: Order tools from your Service-Gard Catalog, unless otherwise indicated.

JDST-28 Belt Tensioning Tool is used for checking fan belt tension.

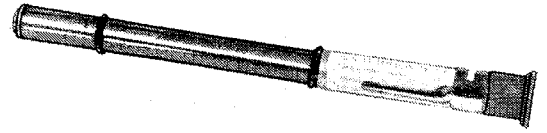

R 26415N

A14;R26415 N U03;01000 G 080181

D-05104ST Radiator Tester is used for pressure testing cooling system and radiator caps.

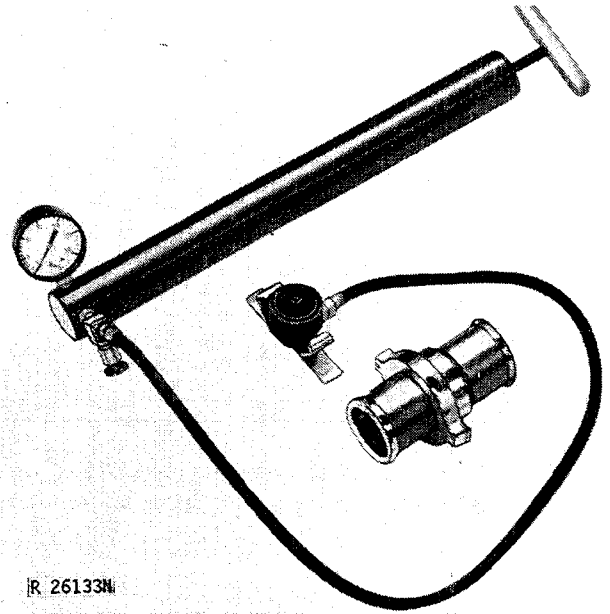

R 26133N

A14;R26133N U03;01000 I 070283

AR62377 Dry Element Cleaning Gun is used for cleaning air filter.

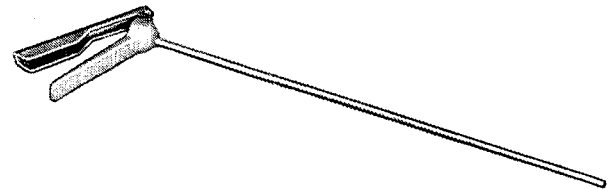

R27167N

A14;R27167 N U03;01000 J 080181

Specifications and Special Tools

D-05022ST Water Vacuum Gauge is used to measure air intake vacuum.

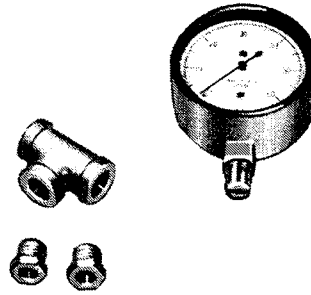

AC1/R27168 U10:010000 MX2 171181

JDG-241 Engine Rotation Tool (A) and JDG-242 Timing Pin (B) are used to turn engine to TDC to check injection pump timing.

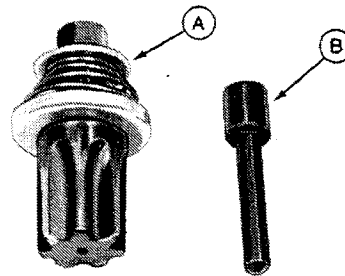

AC1/R26134 U10:010000 IX2 171181

D-19001TT Volt-Ohm-Amp Meter is used to test any electrical components for voltage, resistance, or current draw.

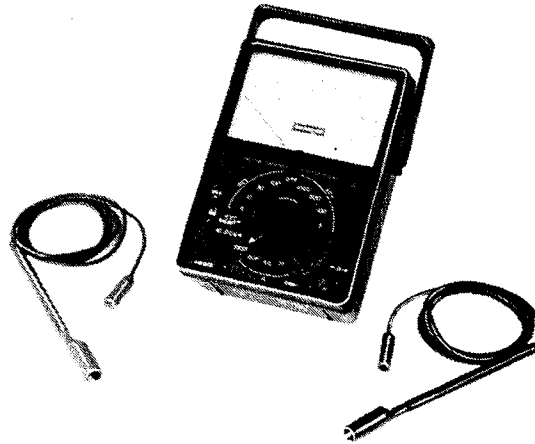

AC1/R28795 N U10:010000 JX2 171181

PREDELIVERY, DELIVERY AND AFTER-SALE SERVICES**DEALER PREDELIVERY SERVICE**

The John Deere delivery receipt, when properly filled out and signed by the dealer and customer, verifies that predelivery and delivery services were satisfactorily performed. When delivering the tractor, give the customer his copy of the delivery receipt and operators manual. Be sure to explain their purposes to him.

Because of the shipping factors involved, plus extra finishing touches necessary to promote customer satisfaction, there are certain predelivery services that must be performed by the dealer. These services are listed in the first of two sections on the predelivery form which is attached to the tractor. The second section is a list of factory inspections that must be verified by the dealer.

Fill the form in completely and sign it. Send a copy to the factory and file the original with the shop order for the job. This will certify that the proper predelivery service has been completed.

Using the following illustrated procedures, perform all services listed and check each job off as it is completed.

U03-01005 A 211281

1. CHARGE BATTERY (IES) (IF NEEDED).

Check batteries for proper charge. With stop cable pulled out, turn key on and crank engine for 5 seconds. This will remove the surface charge from batteries.

Remove side screens on right and left side and then remove negative and positive series connectors (A) from batteries.

Use D-19001TT Volt-Ohm Meter (B) to check voltage. Use chart to find what per cent of charge batteries are charged.

OPEN CIRCUIT VOLTAGE TEST

12-V battery	% of charge
12.6 or more	100
12.4	75
12.2	50
12.0	25
11.7 or less	0

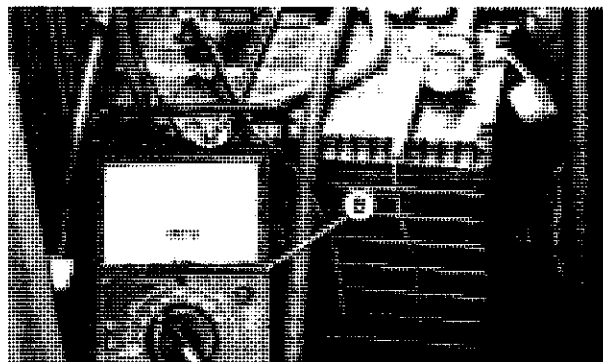

AC2:RW3167,RW3201 U10:010005 CAX2 061282

2. INSTALL STARTING FLUID CAN.

CAUTION: Starting fluid is highly flammable. Do not use near fire, sparks or flames.

IMPORTANT: To avoid engine damage, inject fluid only in small amounts and only while engine is turning. Do not depress button longer than one second at a time.

Install starting fluid can (A). To check operation, inject starting fluid by depressing button on dash.

IMPORTANT: To avoid drawing dust into engine, always keep a starting fluid can in position or clean bottom of canister and install bottom side up (B).

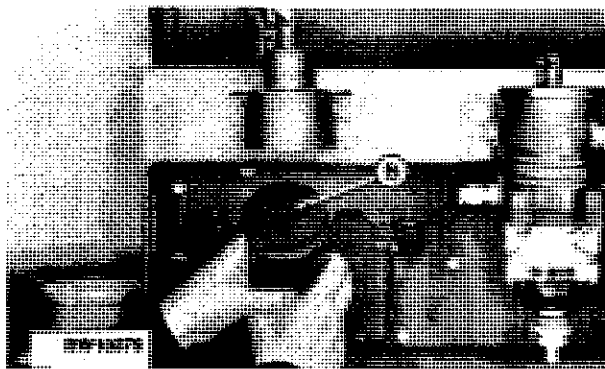
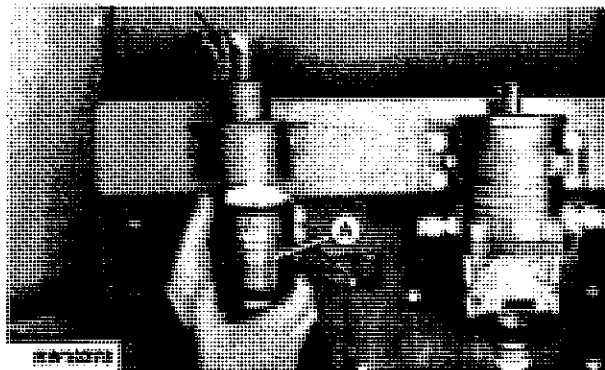

AC2:RW1037 8,RW1037 9 U10;010005 CBX2 040484

3. TIGHTEN AIR INTAKE CONNECTIONS

Tighten air intake connections at air cleaner (A) to 8.5 N·m (6 ft-lbs) torque.

NOTE: When sealing any joint on air intake pipe, refer to Section 30, Remove/Install - Air Intake System.

Inspect exhaust system for leaks or restrictions.

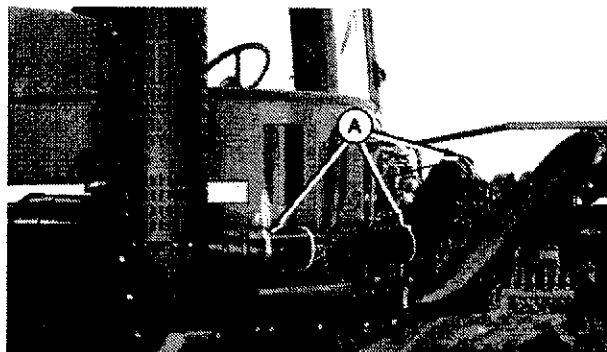

AC2:RW8524 U10;010005 CCX1 021282

4. ADJUST ALL LAMPS.

Make sure lights work properly when switch (A) is in following positions:

- OFF — To turn off lights
- W — To turn on warning lamps
- H — To turn on dual-beam head lamps, warning lamps, and red tail lamps
- F — To turn on dual-beam head lamps, and flood lamps

Adjust flood lamps for maximum field operation.

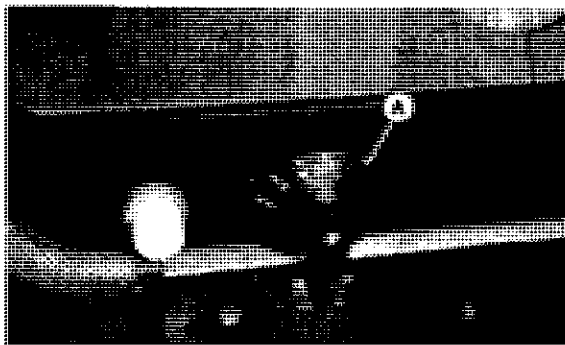

AC2:RW7840 U10;010005 CDX1 021282

4. ADJUST ALL LAMPS.

Make sure lights work properly when switch (A) is in following positions:

- OFF — To turn off lights
- W — To turn on warning lamps
- H — To turn on dual-beam head lamps, warning lamps, and red tail lamps
- F — To turn on dual-beam head lamps, and flood lamps

Adjust flood lamps for maximum field operation.

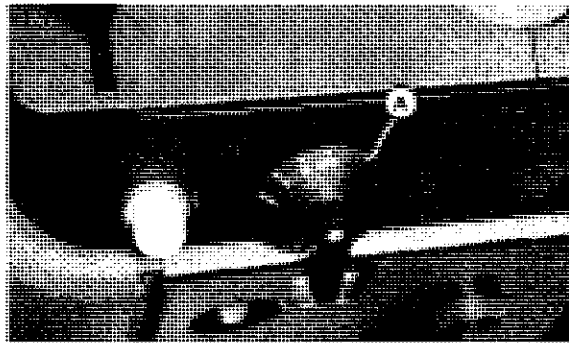

AC2:RW784C U10:010005 CDX1 021282

TO AIM HEAD LAMPS:

1. Park tractor on level ground, 8 m (25 ft.) from a wall.
2. Measure height of center lamps above the ground, and place a strip of masking tape on wall at same height (A).
3. Sight across steering wheel and hood ornament to locate tractor centerline, mark this spot on tape (B).

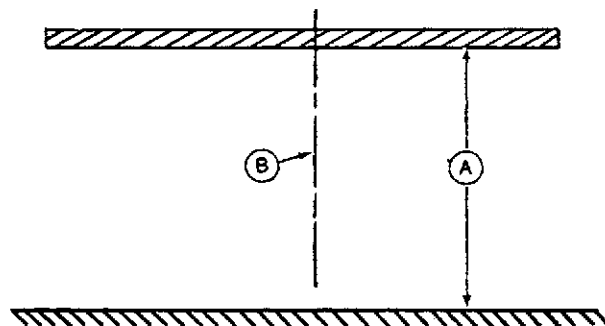

AC2:RW4890 U10:010005 BXX3 010782

4. From centerline mark a point 305 mm (12 in.) out in each direction (A). This locates a point directly in front of each lamp center.
5. Turn light switch to "H" and dimmer switch to low beam.
6. Locate small zone of bright light projected by each lamp. Cover other lamps if necessary. Top of zone should be 130 mm (5 in.) lower than lamp center (B). Left edge of zone should be 130 mm (5 in.) left of lamp center (C).

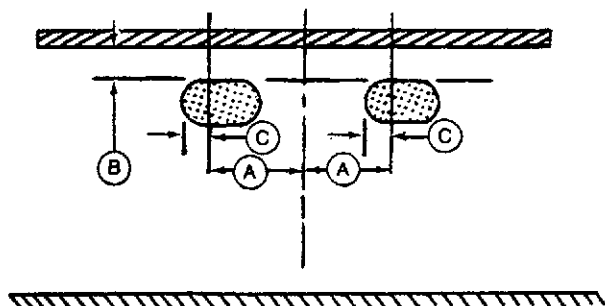

AC3:RW4891 U10:010005 BTX3 010782