



# 90 Skid-Steer Loader



JOHN DEERE

## TECHNICAL MANUAL

---

90 Skid-Steer  
Loader

TM1205 (01NOV78) English

John Deere  
Lawn & Grounds Care Division  
TM1205 (01NOV78)

LITHO IN U.S.A.  
ENGLISH



# 90 SKID-STEER LOADER

TECHNICAL MANUAL  
TM-1205 (NOV-78)

## CONTENTS

- SECTION 10 - GENERAL  
 Group 05 - Specifications  
 Group 10 - Lubrication and Periodic Service
- SECTION 25 - GASOLINE ENGINE REPAIR  
 Group 05 - Specifications and Tools  
 Group 10 - Engine Separation  
 Group 15 - Disassembly  
 Group 20 - Assembly
- SECTION 30 - FUEL REPAIR  
 Group 05 - Specifications  
 Group 10 - Carburetor  
 Group 15 - Governor
- SECTION 40 - ELECTRICAL REPAIR  
 Group 05 - Specifications  
 Group 10 - Starter
- SECTION 50 - POWER TRAIN REPAIR  
 Group 05 - Specifications  
 Group 10 - Hydrostatic Pump  
 Group 15 - Hydrostatic Motor  
 Group 20 - Final Drive
- SECTION 60 - STEERING AND BRAKE REPAIR  
 Group 05 - Steering  
 Group 10 - Brakes
- SECTION 70 - HYDRAULIC REPAIR  
 Group 05 - Hydraulic Pump  
 Group 10 - Hydraulic Cylinders
- SECTION 225 - GASOLINE ENGINE, FUEL AND  
 AIR OPERATION AND TESTS  
 Group 05 - Specifications  
 Group 10 - System Operation  
 Group 15 - Engine Analysis  
 Group 20 - Diagnosing Malfunctions
- SECTION 240 - ELECTRICAL OPERATION AND  
 TESTS  
 Group 05 - Specifications  
 Group 10 - System Operation  
 Group 15 - System Testing  
 Group 20 - Diagnosing Malfunctions
- SECTION 250 - POWER TRAIN OPERATION AND  
 TESTS  
 Group 05 - Specifications  
 Group 10 - System Operation  
 Group 15 - System Testing  
 Group 20 - Diagnosing Malfunctions
- SECTION 270 - HYDRAULIC OPERATION AND  
 TESTS  
 Group 05 - Specifications  
 Group 10 - System Operation  
 Group 15 - System Testing  
 Group 20 - Diagnosing Malfunctions

*(All information, illustrations, and specifications contained in this technical manual are based on the latest information available at the time of publication. The right is reserved to make changes at any time without notice.)*

Copyright © 1978  
 DEERE & COMPANY  
 Moline, Illinois  
 All Rights Reserved

## INTRODUCTION

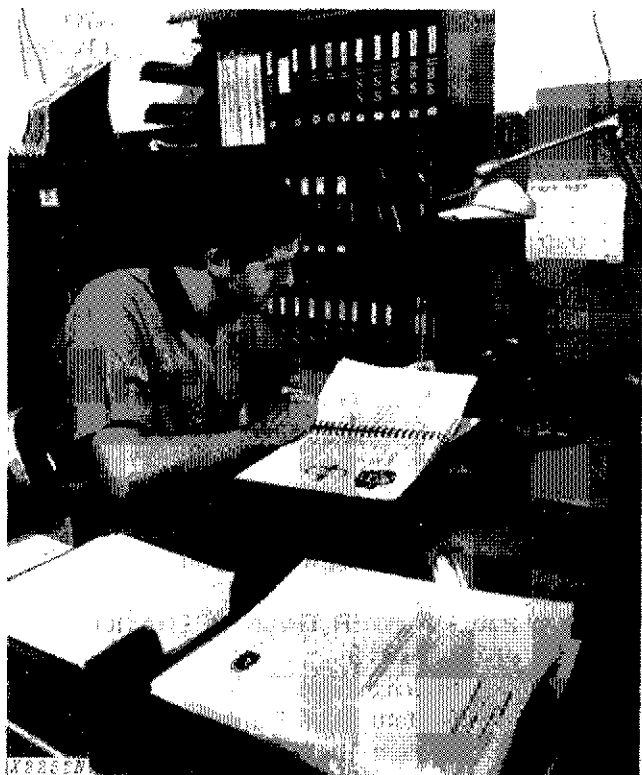

*Use FOS Manuals for Reference*

This technical manual is part of a twin concept of service:

- **FOS Manuals—for reference**
- **Technical Manuals—for actual service**

The two kinds of manuals work as a team to give you both the general background and technical details of shop service.

*Fundamentals of Service (FOS) Manuals* cover basic theory of operation, *fundamentals* of trouble shooting, *general* maintenance, and *basic* types of failures and their causes. FOS Manuals are for training new men and for reference by experienced men.

*Technical Manuals* are concise on-the-job service guides containing only the vital information needed for a specific machine.

When a serviceman should refer to a FOS Manual for more information, a FOS symbol like the one at the left is used in the TM to identify the reference.



*Use Technical Manuals for Actual Service*

Some features of this technical manual:

- *Table of contents at front of manual*
- *Exploded views showing parts relationship*
- *Photos showing service techniques*
- *Specifications grouped for easy reference*

This technical manual was planned and written for you—a journeyman mechanic. Keep it in a permanent binder in the shop where it is handy. Refer to it whenever in doubt about correct service procedures or specifications.

Using the technical manual as a guide will reduce error and costly delay. It will also assure you the best in finished service work.

### SI UNITS OF MEASURE

Because John Deere sells its products world-wide, U.S. units of measure are shown with their respective Metric equivalents throughout this technical manual. These equivalents are the SI (International System) Units of Measure.

# Section 10 GENERAL

## CONTENTS

	Page		Page
<b>GROUP 05 - SPECIFICATIONS</b>		<b>GROUP 10 - LUBRICATION AND PERIODIC SERVICE</b>	
Engine .....	05-1	Lubricants .....	10-1
Hydraulic System .....	05-1	Lubrication .....	10-2
Drive System .....	05-2	Periodic Service .....	10-4
Travel .....	05-2	As Required .....	10-5
Fluid Capacity .....	05-2	10 Hours or Daily .....	10-7
Tires .....	05-2	50 Hours or Weekly .....	10-8
Attachments .....	05-2	100 Hours .....	10-9
Operational Specifications .....	05-2	200 Hours .....	10-11
Dimensions .....	05-3	500 Hours .....	10-13
Bucket and Fork Specifications .....	05-4	1000 Hours or Annually .....	10-14

## Group 05 SPECIFICATIONS

### ENGINE

Make .....	Onan
Model .....	NHC-MS3406C
Fuel .....	Gasoline (Regular)
Cooling System .....	Air
Cylinders .....	2
Displacement .....	60 cu. in. (983.2 cm <sup>3</sup> )
Bore .....	3.56 in. (90.4 mm)
Stroke .....	3.0 in. (76.2 mm)
Horsepower .....	23 hp (17.1 kW)
Maximum Governed rpm .....	3200 rpm
Maximum Torque .....	41 ft-lbs (56 Nm) @ 2200 rpm
Electrical System .....	12-Volt with 20 amp flywheel and regulator
Battery .....	12-volt — 60 amp hr. Cold cranking amps rating @ 0°F — 500 @ -20°F — 380
Ignition System	
Point Gap .....	0.020 in. (0.58 mm)
Spark Plug	
Gap .....	0.025 in. (0.64 mm)
Type .....	Resistor

### HYDRAULIC SYSTEM

Pump Capacity .....	7.5 gpm (28.4 L/min) @ 3600 rpm gear type
Control	
Main Valve: Dual pedal, two-spool control valve	
Auxiliary Valve: Single pedal, single-spool control valve	
Relief Valve Setting	
Main Valve: 1750 psi (120 bar) (123 kg/cm <sup>2</sup> )	
Auxiliary Valve: 1600 psi (112.5 kg/cm <sup>2</sup> ) (110 bar)	
Filters	
Hydrostatic .....	10 micron
Hydraulic .....	100 mesh screen
Hydraulic Cylinders	
Lift (Double Acting):	
Bore Diameter .....	2 in. (50.8 mm)
Rod Diameter .....	1 in. (25.4 mm)
Stroke .....	22 in. (558.8 mm)
Tilt (Double Acting):	
Bore Diameter .....	2-1/2 in. (63.5 mm)
Rod Diameter .....	1-1/4 in. (31.8 mm)
Stroke .....	13-1/8 in. (333.4 mm)

### DRIVE SYSTEM

Two hydrostatic pumps with variable angle swashplate and two hydrostatic motors with fixed angle swashplate. Forward, rearward and turning movements are controlled by a T-bar control lever.

### TRAVEL

Speed ..... 0-4 mph  
(0-8 km/h)

Turning ..... 360° in its own length

### FLUID CAPACITY

Fuel Tank ..... 8 U.S. Gallons (30.4 L)  
Engine Lubricating Oil ..... 4 U.S. Quarts (3.8 L)  
Hydraulic/Hydrostatic Reservoir ..... 11 U.S. Gallons (41.8 L)  
Chain Case Reservoir ..... 1-1/2 U.S. Gallons (5.7 L)

### TIRES

Size	Operating Pressure
27x8.50-15	30 psi (2 bar) (2 kg/cm <sup>2</sup> )

### ATTACHMENTS

Auxiliary hydraulic valve kit, cylinder rod stops, earth bucket, utility bucket, pallet fork, utility fork, grapple, and SMV emblem.

### OPERATIONAL SPECIFICATIONS

Operating weight ..... 2825 lbs. (1 281.4 kg)  
Tipping load (SAE with 47 in. [1 194 mm] bucket) ..... 1400 lbs. (635 kg)  
Load Rating (1/2 SAE tip-up) ..... 700 lbs. (317.5 kg)  
Lift capacity to maximum height ..... 1300 lbs (590 kg)  
Raising time to full height (full) ..... 5 seconds  
Lowering time (empty) ..... 3 seconds  
Dumping time (full) ..... 2.5 seconds  
Rollback time (full rollback) ..... 2.5 seconds

**DIMENSIONS**

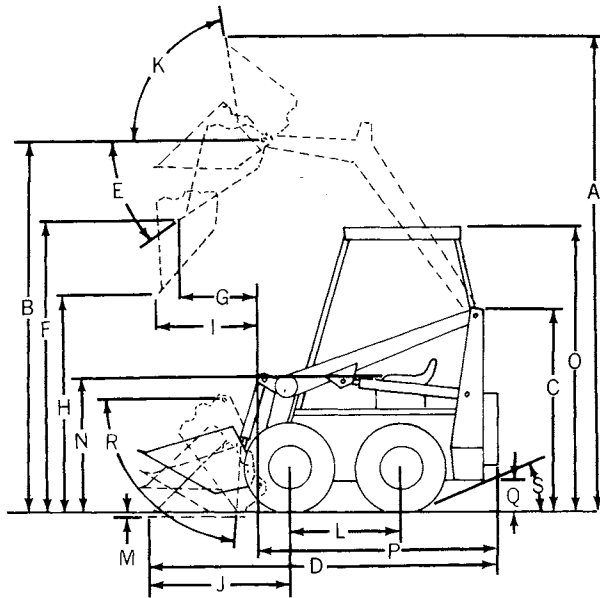

G10865

Fig. 1-Height and Length

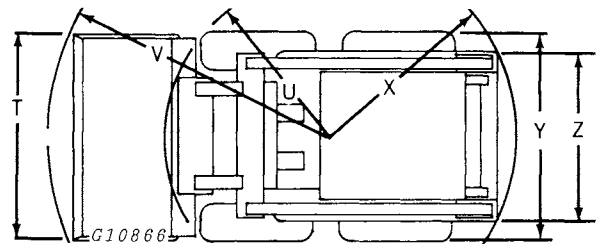

G10866

Fig. 2-Width

Specifications are in accordance with IEMC Standards  
 Dimensions are with 27x8.50-15 Tires and 47-Inch (1 194 mm) Earth Bucket

A - Overall height (lift arms raised).....	125 in. (3 175 mm)
B - Height to hinge pin (maximum).....	98 in. (2 489.2 mm)
C - Overall height.....	54 in. (1 372 mm)
D - Overall length (with bucket).....	102 in. (2 591 mm)
E - Dump angle.....	38°
F - Dump height.....	73 in. (1 854.2 mm)
G - Reach at maximum height.....	18 in. (457.2 mm)
H - Specified height.....	51.5 in. (1 308.1 mm)
I - Reach (specified height).....	27 in. (685.8 mm)
J - Reach (bucket on ground).....	26 in. (600.4 mm)
K - Maximum rollback (fully raised).....	86°
L - Wheelbase.....	30.75 in. (781 mm)
M - Digging depth (above ground).....	9/16 in. (14.3 mm)
N - Height to seat.....	33.5 in. (851 mm)
O - Overall height (with operator guard).....	74 in. (1 880 mm)
P - Overall length (less bucket).....	80 in. (2 032 mm)
Q - Ground clearance.....	6.75 in. (171.45 mm)
R - Maximum grading angle (bucket).....	108°
S - Angle of departure.....	23°
T - Bucket width.....	47 in. (1 194 mm)
U - Clearance circle, front (less bucket).....	35 in. (889 mm)
V - Clearance circle, front (with bucket).....	61 in. (1 549.4 mm)
X - Clearance circle, rear.....	47 in. (1 194 mm)
Y - Overall width (less bucket).....	45.5 in. (1 156 mm)
Z - Tread (27x8.50-15 tires).....	37 in. (940 mm)

**BUCKET AND FORK SPECIFICATIONS**

Item	Width	Length	Capacity		Weight
			SAE Struck	SAE Heaped	
Earth Bucket	47 in. (1 193.8 mm)	-----	-----	6 cu. ft. (0.14 m <sup>3</sup> )	150 lbs. (68 kg)
Light Material Bucket	52 in. (1 321 mm)	-----	9 cu. ft. (0.25 m <sup>3</sup> )	11 cu. ft. (0.31 m <sup>3</sup> )	162 lbs. (72 kg)
Utility Bucket	47 in. (1 193.8 mm)	-----	7 cu. ft. (0.20 m <sup>3</sup> )	9 cu. ft. (0.25 m <sup>3</sup> )	147 lbs. (66.68 kg)
Pallet Fork and Frame	30 in. (965.2 mm)	36 in. (914.4 mm)	-----	-----	220 lbs. (99.79 kg)
Utility Fork	39 in. (990.6 mm)	28 in. (711.7 mm)	-----	-----	155 lbs. (70.31 kg)



# Group 10

## LUBRICATION AND PERIODIC SERVICE

### LUBRICANTS

#### Engine Oil

If oil other than Torq-Gard Supreme™ is used, it must conform to the following specifications:

**Single Viscosity Oils**

API Service CD/SD  
MIL-L-2104C\*  
Series 3\*

**Multi-Viscosity Oils**

API Service CC/SE  
CC/SD or SD MIL-L46152

Select oil viscosity depending on the highest expected prevailing temperature for the fill period.

Air Temperature	John Deere Torq-Gard Oil	Other Oils	
		Single Viscosity Oil	Multi-Viscosity Oil
Above 32°F (0°C)	SAE 30	SAE 30	Not recommended
-10°F to 32°F (-23°C to 0°C)	SAE 10W-20	SAE 10W	SAE 10W-30
Below -10°F (-23°C)	SAE 5W-20**	SAE 5W**	SAE 5W-20**

\*As further assurance of quality, the oil should be identified as suitable for API Service Designation SD.

\*\*Some increase in oil consumption may be expected when SAE 5W-20 or SAE 5W oils are used. Check oil level more frequently.

#### Hydrostatic Fluid

Use John Deere All-Weather Hydrostatic Fluid or an equivalent Type "F" Automotive Automatic Transmission Fluid.

#### Greases

Use John Deere Multi-Purpose type lubricant or equivalent SAE multipurpose-type grease for all grease fittings.

### LUBRICATION



**CAUTION: Stop engine before lubricating loader.**

Replace missing grease fittings.

#### SYMBOLS



Lubricate with John Deere Multi-Purpose Lubricant or an equivalent SAE multipurpose-type grease at the hourly intervals indicated on the symbols.



Lubricate periodically with John Deere PT508 or equivalent oil.

#### LUBRICATION CHART

Component	5 Hours or Daily	Reference
1. Grapple Cylinder Pivot Points	Lubricate grease fittings.	See page 10-10-3.
2. Lift Arm and Cylinder Pivot Points	Lubricate grease fittings.	See page 10-10-3.
3. Tilt Cylinder and Quik-Tatch Pivot Points	Lubricate grease fittings.	See page 10-10-3.
	<b>100 Hours or Quarterly</b>	
4. Lift Arm Stop Pins	Lubricate guide rails and lock shafts.	See page 10-10-3.

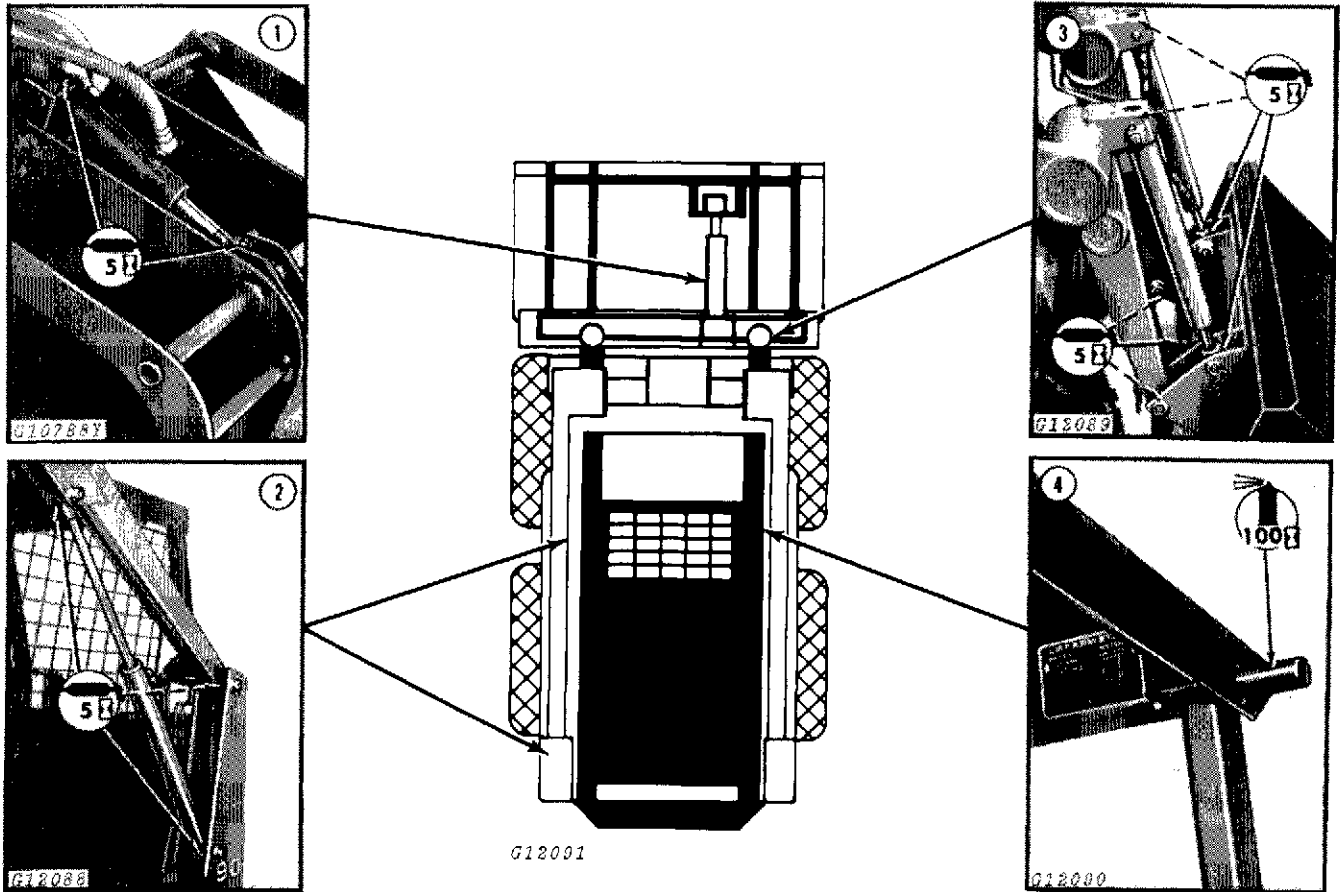

Fig. 1-Lubrication Points

## PERIODIC SERVICE

Component	As Required	Reference Page
1. Fuse	Replace.	10-10-5
2. Hydraulic Pump Drive Belt	Check tension.	10-10-5
3. Hydrostatic Pump Drive Belt	Check tension.	10-10-5
<b>10 Hours or Daily</b>		
4. Air Cleaner	Check element.	10-10-7
5. Engine Crankcase Oil	Check oil level.	10-10-7
6. Hydraulic/Hydrostatic System Reservoir	Check level.	10-10-8
7. Brakes	Check tension.	10-10-8
8. Fuel Tank	Check fuel level.	10-10-8
<b>50 Hours or Weekly</b>		
9. Tires	Check inflation.	10-10-8
10. Engine Air Cleaner	Check element.	10-10-8
<b>100 Hours</b>		
11. Ignition Points and Condenser	Replace.	10-10-9
12. Spark Plugs	Clean and regap.	10-10-10
13. Engine Crankcase Oil and Filter	Drain. Replace filter and refill.	10-10-10
<b>200 Hours</b>		
14. Hydraulic Pump Drive Belt	Check tension.	10-10-11
15. Hydrostatic Pump Drive Belt	Check tension.	10-10-11
16. Hydrostatic System Filter	Replace element.	10-10-11
17. Chain Case Breathers	Remove and clean.	10-10-11
18. Chain Case Reservoir	Check level.	10-10-12
19. Drive Chains	Check and adjust.	10-10-12
<b>500 Hours</b>		
20. Fuel Filter	Replace filter	10-10-13
21. Hydrostatic Pump Mounting Bolts	Check tightness.	10-10-13
22. Engine Cooling System	Clean air passages.	10-10-13
23. Engine Combustion Chambers	Remove deposits.	10-10-13
<b>1000 Hours or Annually</b>		
24. Engine Speed	Check rpm.	10-10-14
25. Engine Valve Tappets	Adjust clearance.	10-10-14
26. Fuel Tank	Drain and refill.	10-10-14
27. Crankcase Breather	Remove and clean.	10-10-14
28. Hydraulic/Hydrostatic System Reservoir and Strainer	Drain, inspect strainer and refill.	10-10-14
29. Battery	Clean terminals.	10-10-15
30. Chain Case Reservoir	Drain chain case.	10-10-16

## AS REQUIRED

## 1. Fuse

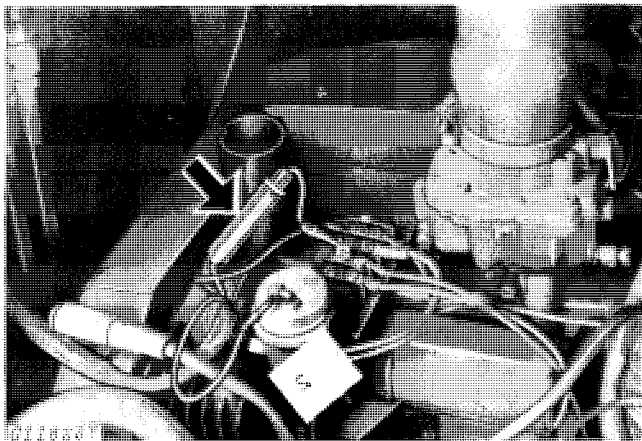

Fig. 2-Fuse

A 30-amp starter solenoid fuse is located on the left-hand side of the carburetor in the engine compartment.

A burned out starter solenoid fuse indicates a dead short in the wiring harness.

## 2. Hydraulic Pump Drive Belt

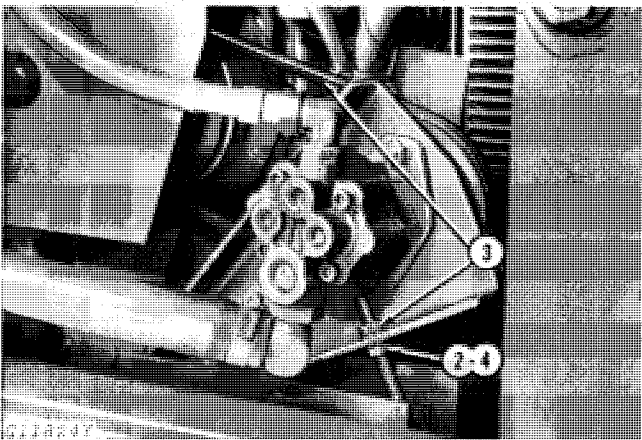

Fig. 3-Hydraulic Pump Drive Belt

1. (Not illustrated.) Open rear guard grille.
2. Loosen bottom lock nut on pump bracket.
3. Tighten top adjustment nut until belt has 3/8-inch (10 mm) deflection at 20 pounds (9 kg) pressure midway between sheaves.
4. Tighten bottom lock nut.

## 3. Hydrostatic Pump Drive Belt

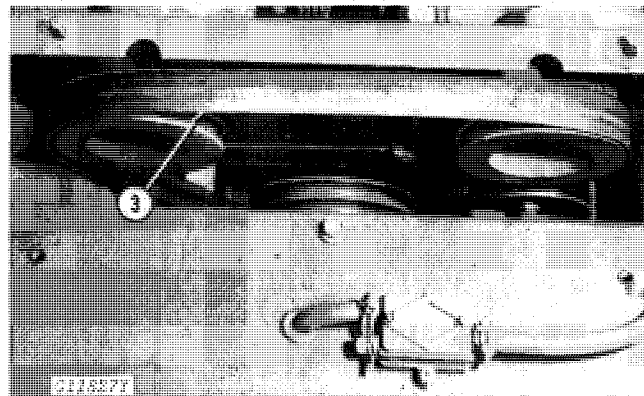

Fig. 4-Checking Belt Tension

1. (Not illustrated.) Remove seat.
2. (Not illustrated.) Remove screen.
3. With clutch lever engaged, check belt tension midway between pump sheaves.

Belt deflection should be 1/2-inch (15 mm) at 20 pounds (9 kg) pressure.

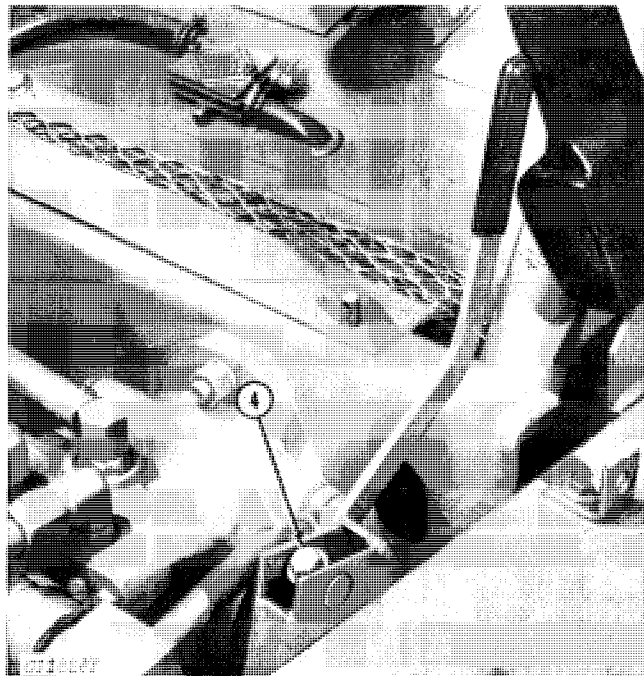

Fig. 5-Adjusting Belt Tension

4. Tighten adjustment screw at the base of the clutch lever until correct deflection is reached.

**NOTE:** Check drive belt for signs of wear or damage and replace if necessary.

AS REQUIRED—Continued

Belt Replacement

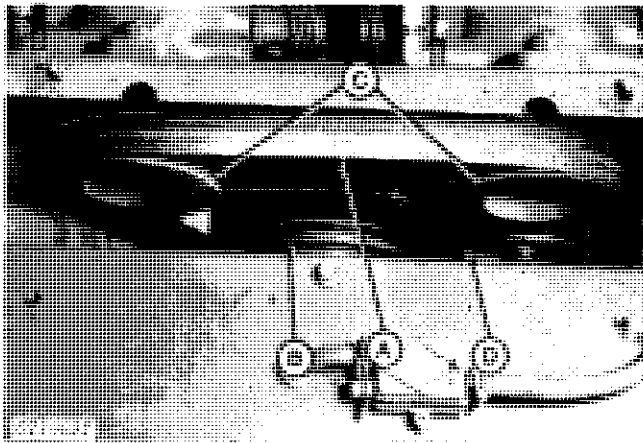

- A—Drive Belt
- B—Drive Pulley
- C—Pump Pulleys
- D—Drive Clutch Pulley

Fig. 6-Belt Replacement

*NOTE: Drive clutch must be disengaged. Install drive belt (A) under drive pulley (B).*

Route drive belt (A) over two pump pulleys (C) to inside of drive clutch pulley (D).

Pulley Alignment

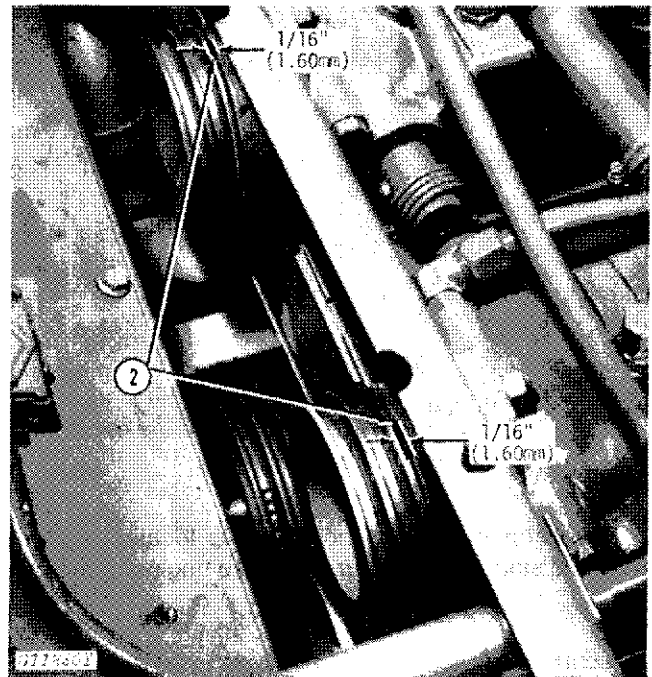

Fig. 7-Pulley Clearance

1. (Not illustrated.) Remove drive belt.
2. Clearance from pump pulley to bearing casting should be maintained at 1/16 inch (1.60 mm).

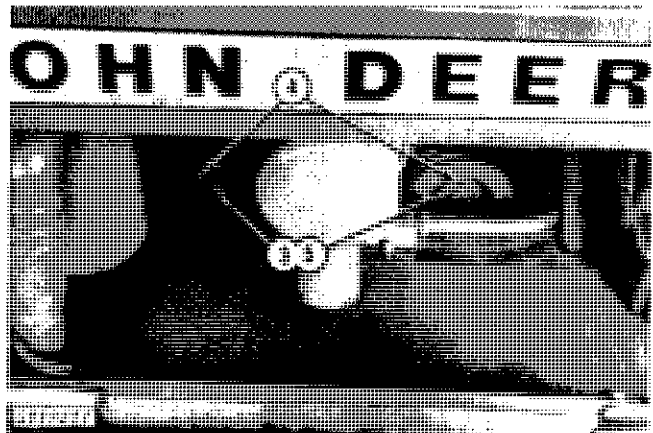

Fig. 8-Adjusting Pulley

3. If adjustment is necessary remove two cap screws from pulley.
4. Loosen pulley by installing screws into opposite set of tapped holes.
5. Locate pulley 1/16 inch (1.60 mm) from bearing casting and replace screws in original set of recessed holes.

*NOTE: Engine mounting bolts can be loosened to position engine pulley.*

**Thank you very much for  
your reading. Please Click  
Here. Then Get COMPLETE  
MANUAL. NO WAITING**



**NOTE:**

**If there is no response to  
click on the link above,  
please download the PDF  
document first and then  
click on it.**

## 10 HOURS OR DAILY

## 4. Air Cleaner

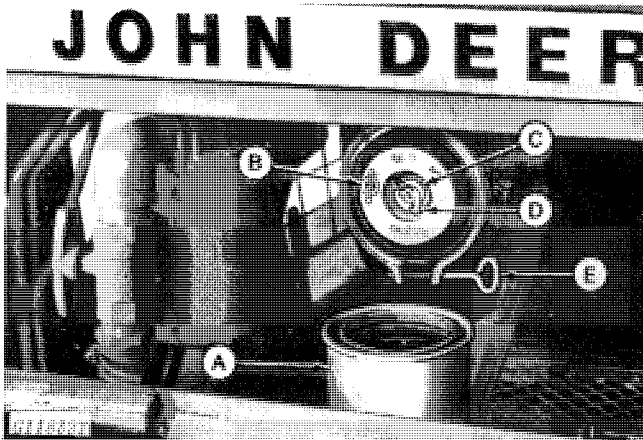

A—Dust Cap  
B—Element  
C—Gasket  
D—Wing Nut  
E—Clamp

Fig. 9-Air Cleaner

Check connections from air cleaner to carburetor.

**IMPORTANT: Replace element after six cleanings or annually, whichever comes first.**

Tap bottom plate of element lightly against palm of hand. If this method does not clean properly, use compressed air (under 30 psi [2.1 bar] 2.1 kg/cm<sup>2</sup>) OSHA regulations.

**IMPORTANT: Do not rupture element.**

**CAUTION:** Never wash element in fuel oil, gasoline or solvents. Do not oil element.

Wash element in warm water and non-sudsing detergent.

Rinse thoroughly.

Shake dry or use compressed air under 40 psi (2.8 bar) and allow to dry 24 to 72 hours.

**IMPORTANT: Protect element from freezing until dry.**

Inspect element. Hold the large end of element toward a bright light and look for holes or cracks. Replace if necessary.

When replacing dust cap make certain arrow on cap is pointing upward.

**IMPORTANT: Do not operate engine without element in place. Under no circumstances use a wet or damp element! Replace the element after not more than six washings or annually, whichever occurs first.**

## 5. Engine Crankcase Oil

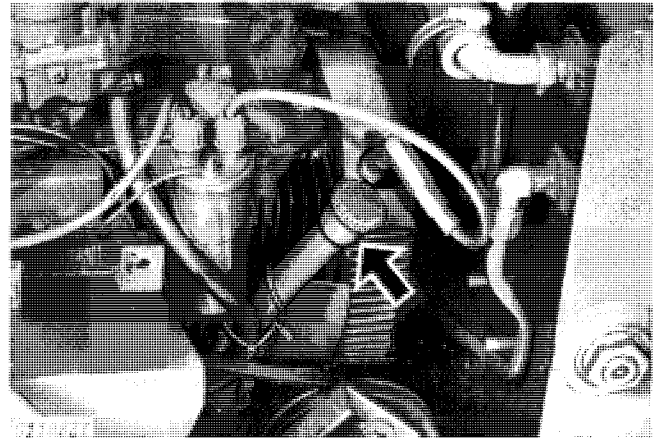

Fig. 10-Checking Oil Level

Check crankcase oil level with loader on a level surface and engine stopped.

Add oil as needed to mark on dipstick. See page 10-10-1 for proper viscosity.

**IMPORTANT: Do not overfill.**



## 6. Hydraulic/Hydrostatic System

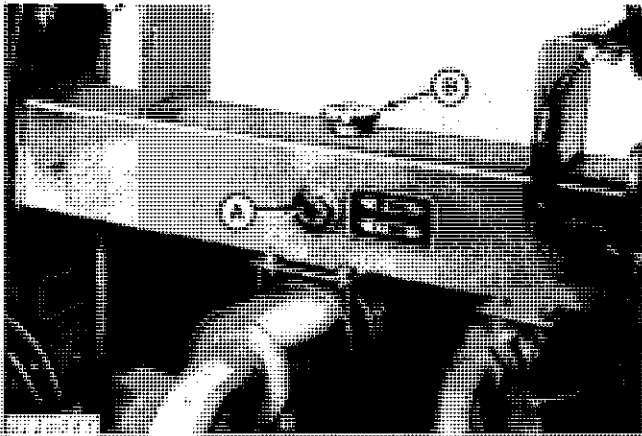

A—View Gauge B—Filler Spout

Fig. 11-Checking Fluid Level

Check oil level through view gauge (A).

**CAUTION:** Loosen cap slowly to allow pressure to escape.

Remove fill cap and add All-Weather Hydrostatic Fluid or an equivalent Type "F" Automotive Transmission Fluid through filler spout (B) until level is at top of view gauge.

## 7. Brakes

Check tension by depressing brake pedal. If travel is more than 4 inches (102 mm), adjustment is necessary.

### Brake Adjustment

1. (Not illustrated.) Remove operator's seat.
2. (Not illustrated.) Remove floor plate.

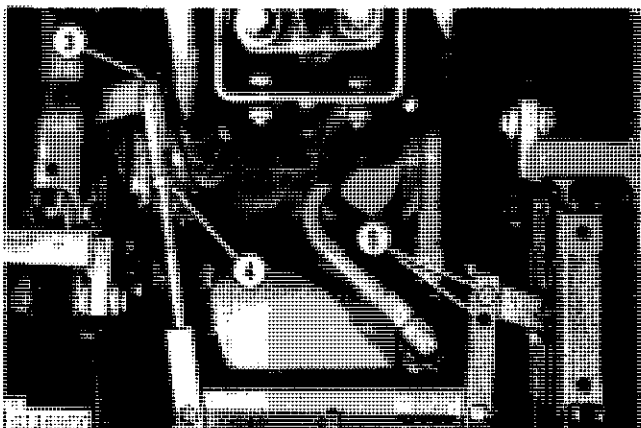

Fig. 12-Setting Pedal Travel

3. Remove cotter and clevis pin from linkage.
4. Loosen linkage nut and rotate clevis clockwise to tighten.

Check brake pedal for the correct travel setting of 1-1/4 inches (92 mm) to 2 inches (51 mm).

5. If more take-up is required, move pin to forward hole in linkage.

**NOTE:** If above procedure is unsuccessful, or brake is pulling to the left or right, brake pad replacement may be required.

### Brake Pad Replacement

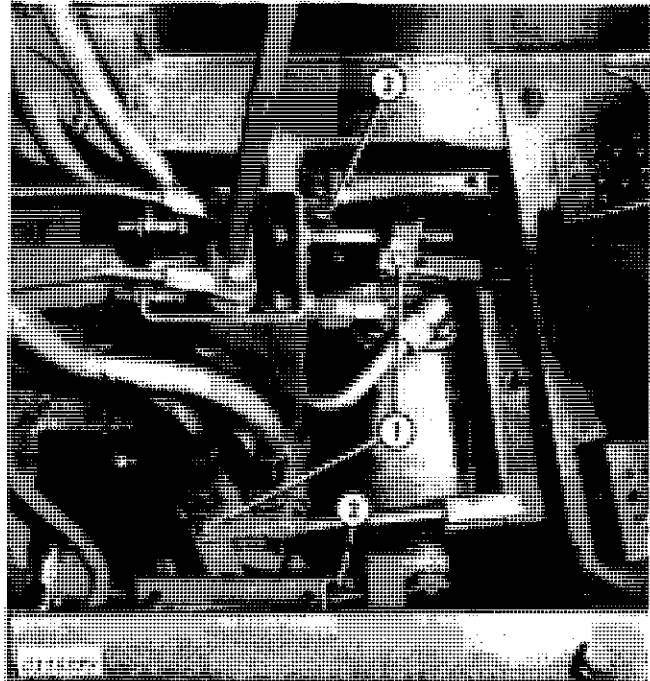

Fig. 13-Replacing Pad

1. Remove clevis and cotter pins from brake linkage.
2. Remove shoulder bolts from brake housings. Remove and replace brake pads.

## 8. Fuel Tank

Fill fuel tank with regular gasoline having an octane rating of 90 at the end of each day to prevent moisture from forming in tank.

### 50 HOURS OR WEEKLY

## 9. Tires

Check and inflate tires if necessary to 30 psi (2 bar) (2 kg/cm<sup>2</sup>).

## 10. Engine Air Cleaner

Remove air cleaner and tap it lightly on a hard surface to remove loose dirt particles.