

**John Deere
JD693-B
Feller-Buncher**

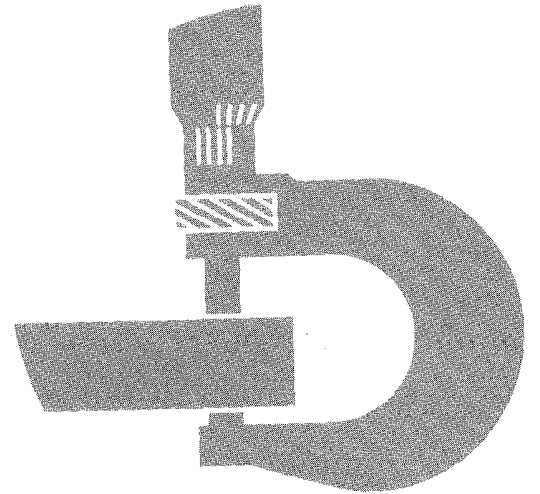

TECHNICAL MANUAL

TM-1170

Litho in U.S.A.

SECTION AND GROUP CONTENTS OF THIS MANUAL

SECTION I - GENERAL INFORMATION

- Group I - Contents, Index and Page List
- Group II - Introduction and Safety Information
- Group III - General Specifications
- Group IV - Predelivery, Delivery and After-Sales Service
- Group V - Lubrication

SECTION 1 - TRACKS

- Group 0130 - Tracks Systems
- Group 0199 - Specifications and Special Tools

SECTION 2 - AXLES AND SUSPENSION SYSTEMS

- Group 0201 - Drive Axle Housing and Support
- Group 0260 - Hydraulic System
- Group 0299 - Specifications and Special Tools

SECTION 4 - ENGINE

- Group 0400 - Engine Removal and Installation
- Group 0401 - Crankshaft and Main Bearings
- Group 0402 - Camshaft and Valve Actuating Means
- Group 0403 - Connecting Rods and Pistons
- Group 0404 - Cylinder Block
- Group 0407 - Oiling System
- Group 0408 - Ventilating System
- Group 0409 - Cylinder Head and Valves
- Group 0410 - Exhaust Manifold
- Group 0413 - Fuel Injection System
- Group 0414 - Intake Manifold
- Group 0416 - Turbocharger
- Group 0417 - Water Pump
- Group 0418 - Thermostats, Housings and Water Piping
- Group 0419 - Oil Cooler
- Group 0420 - Fuel Filter
- Group 0421 - Fuel Transfer Pump
- Group 0422 - Starting Motor and Fastenings
- Group 0433 - Flywheel, Housing and Fastenings
- Group 0499 - Specifications and Special Tools

SECTION 5 - ENGINE AUXILIARY SYSTEM

- Group 0505 - Cold Weather Starting Aids
- Group 0510 - Cooling Systems
- Group 0515 - Speed Controls
- Group 0520 - Intake System
- Group 0530 - External Exhaust Systems
- Group 0540 - Mounting Frame
- Group 0560 - External Fuel Supply Systems
- Group 0599 - Specifications and Special Tools

SECTION 16 - ELECTRICAL SYSTEMS

- Group 1671 - Batteries, Support and Cables
- Group 1672 - Alternator, Regulator and Charging System Wiring
- Group 1673 - Lighting System
- Group 1674 - Wiring Harness and Switches
- Group 1675 - Systems Controls
- Group 1676 - Instruments and Indicators
- Group 1699 - Specifications and Special Tools

SECTION 17 - FRAME, CHASSIS, OR SUPPORTING STRUCTURE

- Group 1740 - Frame Installation
- Group 1746 - Frame Bottom Guards
- Group 1749 - Chassis Weights

SECTION 18 - OPERATOR'S STATION

- Group 1810 - Operator Enclosure
- Group 1830 - Heating and Air Conditioning
- Group 1899 - Specifications and Special Tools

SECTION 19 - SHEET METAL AND STYLING

- Group 1910 - Hood or Engine Enclosure
- Group 1913 - Miscellaneous Shields
- Group 1921 - Grille and Grille Housing
- Group 1927 - Fenders

SECTION 20 - SAFETY, CONVENIENCE AND MISCELLANEOUS

- Group 2003 - Fire Extinguisher

SECTION 33 - BACKHOE AND EXCAVATOR

- Group 3315 - Controls Linkage
- Group 3340 - Frames
- Group 3360 - Hydraulic System
- Group 3399 - Specifications and Special Tools

SECTION 39 - SHEAR

- Group 3901 - Blades and Cutting Elements
- Group 3903 - Tongue and Forks
- Group 3915 - Controls Linkage
- Group 3940 - Frame
- Group 3960 - Hydraulic System
- Group 3999 - Specifications and Special Tools

SECTION 43 - SWING, ROTATION OR PIVOTING SYSTEM

- Group 4350 - Mechanical Drive Elements
- Group 4360 - Hydraulic System
- Group 4399 - Specifications and Special Tools

SECTION AND GROUP CONTENTS OF THIS MANUAL (Continued)

SECTION 90 - SYSTEM TESTING

- Group 9005 - General Information - Seven Basic
 Steps of Diagnosing and Testing
- Group 9010 - Engine
- Group 9015 - Electrical System
- Group 9020 - Power Train
- Group 9025 - Hydraulic System
- Group 9030 - Miscellaneous Components
- Group 9031 - Heating and Air Conditioning
- Group 9035 - Specifications and Special Tools

INDEX

A

Accessory relay	1674-2
Accumulator, pilot	3360-53
Adjusting cylinder	0130-10
After-sale inspection	I-IV-20
Air cleaner	I-IV-25
Air conditioner	I-IV-42
Air intake hoses	I-IV-25
Batteries	I-IV-26
Chain guides and slides hardware	I-IV-39
Clamp control pedal	I-IV-37
Clamp valve switch	I-IV-37
Crankcase oil level and filter	I-IV-21
Dual speed propel switch	I-IV-38
Engine crankcase vent tube	I-IV-40
Engine speeds	I-IV-27
Fan belt tension	I-IV-27
Flow divider	I-IV-39
Fluid leakage	I-IV-41
Fuel filters	I-IV-26
Fuel supply pump sediment bowl	I-IV-27
Fuel tank sump filter	I-IV-26
Grease fittings	I-IV-28
Hardware torque values	I-IV-41
House lock control switches	I-IV-36
House lock oil level	I-IV-24
Hydraulic system oil level and filters	I-IV-22
Indicator lights and gauges	I-IV-34
Pre-cleaner	I-IV-25
Propel brake oil level	I-IV-24
Propel pedals	I-IV-35
Radiator	I-IV-25
Seat	I-IV-39
Secondary boom and shear tilt control lever	I-IV-35
Shear control pedal	I-IV-37
Swing and primary boom control lever	I-IV-35
Swing gearbox oil level	I-IV-23
Track gearbox oil level	I-IV-23
Track rollers and idlers oil level	I-IV-24
Track sag	I-IV-39
Track shoe hardware	I-IV-40
Track tension check	I-IV-37
Air cleaner	0520-1
Air conditioning system	1830-4
Air conditioning system testing	9031-2
Air filters	1830-28
Air intake system	1830-27
Alternator indicator light	1676-4
Alternator, regulator and charging system wiring	1672-1
Axles and suspension systems	0201-1

B

Backhoe and excavator:	
Controls linkage	3315-3
Frames	3340-1
Hydraulic system	3360-1
Batteries, support and cables	1671-3
Blades and cutting elements, shear	3901-3
Boom cylinders	3360-21
Booms, primary and secondary	3340-1
Bumper, rear	1749-1

C

Cab guard, sweep and frame	1810-3
Cab relay testing	9015-47
Camshaft and valve actuating means	0402-1
Charging circuit testing	9015-34
Chassis weights	1749-1
Clamp assembly, lower	3903-1
Clamp assembly, upper	3903-3
Clamp cylinder	3960-9
Cold weather starting aids	0505-3
Component location:	
Electrical system	9015-10
Engine system	9010-1
Hydraulic system	9025-1
Power train system	9020-1
Compressor	1830-4
Compressor relief valve	1830-26
Condenser	1830-20
Connecting rods and pistons	0403-1
Control valve, axle system	0260-7
Control valve, backhoe and excavator	3360-6
Control valve pilot caps	3360-60
Control valve, swing system	4360-1
Controls linkage, backhoe and excavator	3315-3
Controls linkage, shear	3915-1
Cooling systems, engine	0510-1
Counterbalance valve, axle system	0260-16
Cover, main frame bottom	1746-2
Cover, swing motor	1913-1
Cover, undercarriage	1746-1
Crankshaft and main bearings	0401-1
Crossover relief valve, swing system	4360-4
Cylinder block	0404-1
Cylinder, boom	3360-21
Cylinder, clamp	3960-9
Cylinder head and valves	0409-1
Cylinder, secondary boom	3360-17
Cylinder, shear	3960-7
Cylinder, tilt	3360-14

D	
Delivery service	I-IV-20
Diagnosing malfunctions:	
Air conditioning system	9031-4
Electrical system	9015-6
Engine system	9010-6
Heating system	9031-1
Hydraulic system	9025-32
Power train system	9020-2
Track system	9030-1
Diagnosis and testing	9005-3
Drive axle housing and support	0201-3

E	
Electrical systems	1671-1
Electrical systems testing	9015-1
Engine	0400-1
Engine auxiliary systems	0505-1
Engine oil pressure gauge	1676-2
Engine system testing	9010-1
Engine water temperature gauge	1676-3
Evaporator	1830-23
Exhaust manifold	0410-1
Expansion valve	1830-24
External exhaust systems, engine	0530-1
External fuel supply systems, engine	0560-1

F	
Fenders	1927-1
Filter, air	1830-28
Filter, fuel, engine	0420-1
Filter, hydraulic oil	3360-26
Filter, oil engine	0407-1
Filter, pilot	3360-58
Fire extinguisher	2003-3
Fire suppression system	2003-5
Flow divider valves	0260-10
Fluid starting aid	0505-3
Flywheel, housing and fastenings	0433-1
Foot-operated pilot control valves	3360-37
Frame, backhoe and excavator	3340-1
Frame bottom guards	1746-1
Frame, main	1740-3
Frame, shear	3940-1
Frame, track	0130-3
Front idler	0130-5
Fuel filter	0420-1
Fuel gauge	1676-3
Fuel injection nozzles	0413-5
Fuel injection pump	0413-1
Fuel injection system	0413-1
Fuel tank	0560-1
Fuel transfer pump	0421-1
Fuses	1674-2

G	
Gauge, engine oil pressure	1676-2
Gauge, engine water temperature	1676-3
Gauge, fuel	1676-3
Gauge, hydraulic oil temperature	1676-3
Gauge lights	1673-1
Gauges, testing	9015-42
Greases	I-V-2
Grille	1921-1

H	
Hand held fire extinguisher	2003-3
Hand-operated pilot control valve	3360-28
Heater and air conditioning assembly	1830-3
Heater core	1830-2
Heater pipes and hoses	1830-2
Heater valve	1830-1
Heating system testing	9031-1
High and low refrigerant pressure switches	1830-27
Hood	1910-3
Horn switch	1674-1
Hour meter	1676-2
House lock assembly	4350-8
House lock solenoid testing	9015-45
House lock switches	1675-2
Hydraulic hose routing, backhoe and excavator	3360-11
Hydraulic hose routing, shear	3960-5
Hydraulic oil filter indicator light	1676-4
Hydraulic oil temperature gauge	1676-3
Hydraulic system testing	9025-1
Hydraulics, axle and suspension systems	0260-1
Hydraulics, backhoe and excavator	3360-1
Hydraulics, shear	3960-1
Hydraulics, swing system	4360-1

I	
Indicator lights testing	9015-47
Instrument panel	1676-1
Instruments and indicators	1676-1
Intake system, engine	0520-1
Intake manifold	0414-1

K	
Key switch	1674-1

L	
Light, alternator indicator	1676-4
Light, hydraulic oil filter indicator	1676-4
Light, plugged condenser indicator	1676-4
Light, Rome clamp valve indicator	1676-4
Lights, gauge	1673-1
Lubrication	I-V-1

M

Main frame	1740-3
Main frame bottom covers	1746-2
Main hydraulic pump	3360-1
Main hydraulic pump drive	3360-4
Malfunctions, diagnosing:	
Air conditioning system	9031-4
Electrical system	9015-6
Engine system	9010-6
Heating system	9031-1
Hydraulic system	9025-20
Power train system	9020-2
Track system	9030-1
Manifold, exhaust	0410-1
Manifold, intake	0414-1
Manifold, water	0418-1
Momentary house lock	1675-2
Motor, starting	0422-1
Mounting frame, engine	0540-1
Muffler	0530-1

N

Nozzle, fuel injection	0413-7
------------------------	--------

O

Oil cooler	0419-1
Oil cooler, hydraulic	3360-25
Oil cooler to reservoir hose	3360-26
Oil filters, hydraulic	3360-26
Oil system	0407-1
Oils	I-V-2

P

Permanent house lock	1675-2
Pilot accumulator	3360-53
Pilot filter	3360-58
Pilot shut-off valve	3360-46
Planetary drive	0201-7
Plugged condenser indicator light	1676-4
Power train system testing	9020-1
Pre-cleaner	0520-1
Predelivery service	I-IV-1
Air cleaner	I-IV-5
Air conditioner	I-IV-19
Air intake hoses	I-IV-5
Batteries	I-IV-5
Clamp control pedal	I-IV-15
Clamp valve switch	I-IV-16
Crankcase oil level	I-IV-1
Dual speed propel switch	I-IV-17
Engine speed check	I-IV-7
Fan belt tension	I-IV-6
Final check	I-IV-19
Flow divider	I-IV-17

Predelivery service—Continued

Fuel filters	I-IV-6
Fuel supply pump sediment bowl	I-IV-6
Grease fitting check	I-IV-7
Hardware torque values	I-IV-18
House lock control switches check	I-IV-16
House lock oil level	I-IV-4
Hydraulic system oil level	I-IV-2
Indicator lights and gauges	I-IV-13
Pre-cleaner	I-IV-4
Propel brake oil level	I-IV-4
Propel pedal check	I-IV-14
Radiator	I-IV-5
Secondary boom and shear tilt control lever	I-IV-15
Seat operation	I-IV-17
Shear control pedal	I-IV-16
Swing and primary boom control lever check	I-IV-15
Swing gearbox oil level	I-IV-2
Track gearbox oil level	I-IV-3
Track rollers and idlers oil level	I-IV-3
Track shoe hardware	I-IV-18
Track sag	I-IV-18
Pressure reducing valve	3360-50
Pressurizer motor	1830-27
Propel brake assembly	0260-4
Propel motors	0260-1
Propel switch, two speed	1675-3
Pump, engine water	0417-1
Pump, fuel injection	0413-1
Pump, fuel transfer	0421-1
Pump, oil, engine	0407-1
Pump, main hydraulic	3360-1

R

Radiator	0510-1
Receiver-dryer	1830-21
Reservoir, hydraulic oil	3360-25
Roller, track	0130-7
Rome clamp valve	3960-4
Rome clamp valve circuit testing	9015-42
Rome clamp valve indicator light	1676-4
Rome clamp valve switch	1675-1
Rotary manifold	0260-13

S

Safety information	I-II-2	Specifications and torque values—continued	
Secondary boom cylinder	3360-17	Engine system testing	9035-1
Shear	3901-1	Exhaust manifold	0499-13
Solenoid valve, axles and suspension systems	0260-19	Flywheel, housing and fastenings	0499-24
Solenoid valve, swing system	4360-4	Fuel injection system	0499-14
Special Tools:		General	I-III-1
Air conditioning system	1899-3	Hydraulic system testing	9035-11
Air conditioning system testing	9035-16	Instruments and indicators	1699-3
Alternator, regulator and charging system wiring	1699-5	Intake manifold	0499-16
Backhoe and excavator hydraulic system	3399-5	Oil cooler, engine	0499-20
Batteries, support and cables	1699-4	Oiling system, engine	0499-8
Camshaft and valve actuating means	0499-27	Shear blade and cutting elements	3999-1
Connecting rods and pistons	0499-29	Shear hydraulic system	3999-2
Crankshaft and main bearings	0499-26	Shear tongue and forks	3999-1
Cylinder block	0499-30	Starting motor and fastenings	0499-21
Cylinder head and valves	0499-32	Swing system hydraulics	4399-5
Engine removal and installation	0499-25	Control valve	4399-5
Engine system testing	9035-2	Swing motor	4399-6
Fuel injection system	0499-34	Swing system mechanical drive elements	4399-1
Hydraulic system testing	9035-13	House lock assembly	4399-1
Shear hydraulic system	3999-3	Swing drive assembly	4399-2
Starting motor and fastenings	0499-38	Undercarriage	4399-1
Swing system mechanical drive elements	4399-7	Thermostats, housings and water piping	0499-19
Track systems	0199-5	Track systems	0199-1
Turbocharger	0499-36	Track systems testing	9035-14
Water pump	0499-37	Turbocharger	0499-17
Specifications and torque values:		Water pump	0499-18
Air conditioning system	1899-1	Wiring harness and switches	1699-3
Air conditioning system testing	9035-15	Speed controls, engine	0515-1
Alternator, regulator and charging system wiring	1699-1	Sprocket	0130-5
Axle and suspension system hydraulic system	0299-4	Start switch	1674-1
Backhoe and excavator hydraulic system	3399-1	Starting aid solenoid testing	9015-33, 9015-42
Batteries, support and cables	1699-1	Starting aid switch	1674-1
Camshaft and valve actuating means	0499-3	Starting aids, cold weather	0505-3
Connecting rods and pistons	0499-5	Starting motor and fastenings	0422-1
Crankshaft and main bearings	0499-2	Storage of feller-buncher	I-IV-1
Cylinder block	0499-7	Supports, engine	0540-1
Cylinder head and valves	0499-11	Swing motor cover	1913-1
Drive axle housing and support	0299-1	Swing system	4360-1
Electrical system testing	9035-4	Switch, horn	1674-1
Engine break-in	0499-1	Switch, house lock	1675-2
Engine cooling systems	0599-1	Switch, key	1674-1
Engine external fuel supply systems	0599-1	Switch, Rome clamp valve	1675-1
Engine removal and installation	0499-1	Switch, start	1674-1
		Switch, starting aid	1674-1
		Switch, thermal	1830-27
		Switch, thermostat	1830-25

T

Tests and adjustments:
Air conditioning system 9031-18
Alternator, 42-amp (-3871) 1672-7, 1672-12
Alternator, 62-amp (3872-) 1672-19, 1672-25
Batteries 1671-4
Compressor 1830-17
Electrical system 9015-30
Engine system 9010-9
Hydraulic system 9025-34
Starting motor and fastenings 0422-2, 0422-5
Turbocharger 0416-2
Thermal switch 1830-27
Thermostat switch 1830-25
Thermostats, housings and water piping 0418-1
Tilt cylinder 3360-14
Tongue and forks, shear 3903-1
Track drive 0201-3
Track frame and undercarriages 0130-3
Track idler recoil spring 0130-9
Track rollers 0130-7
Track systems 0130-3
Tracks 0130-12
Track systems testing 9030-1
Turbocharger 0416-1
Two speed propel switch 1675-3
Two speed shift solenoid testing 9015-45

U

Undercarriage 4350-3
Undercarriage covers 1746-1

V

Valve, clamp 3960-1
Valve, compressor relief 1830-26
Valve, control, axle system 0260-7
Valve, control, backhoe and excavator 3360-6
Valve, control, swing system 4360-1
Valve, counterbalance 0260-16
Valve, crossover relief, swing system 4360-4
Valve, expansion 1830-24
Valve, flow divider 0260-10
Valve, foot-operated pilot control 3360-37
Valve, hand-operated pilot control 3360-28
Valve, heater 1830-1
Valve, pilot shut-off 3360-46
Valve, pressure reducing 3360-50
Valve, Rome clamp 3960-4
Valve, shear 3960-1
Valve, solenoid, axles and
suspension systems 0260-18
Valve, solenoid, swing system 4360-4
Ventilator outlet tube 0408-1

W

Water manifold 0418-1
Water pump 0417-1
Wiring harness 1674-1

INTRODUCTION

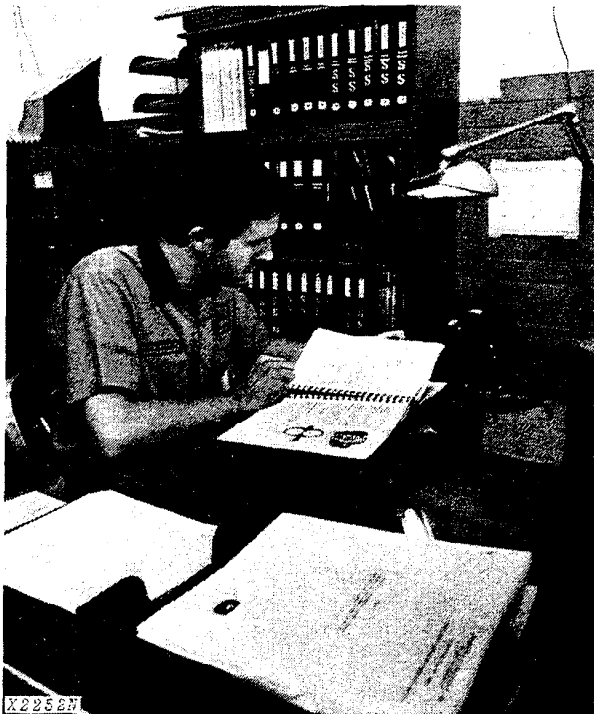

Use FOS Manuals for Reference

This technical manual is part of a twin concept of service:

The two kinds of manuals work as a team to give you both the general background and technical details of shop service.

•FOS Manuals—for reference

Fundamentals of Service (FOS) Manuals cover basic theory of operation, *fundamentals* of trouble shooting, *general* maintenance, and *basic* types of failure and their causes. FOS Manuals are for training new personnel and for reference by experienced technicians.



When a service technician should refer to a FOS Manual for more information, a FOS symbol like the one at the left is used in the technical manual.

•Technical Manuals—for actual service

Technical Manuals are *concise* service guides for *specific* machines. Technical manuals are on-the-job guides containing only the vital information needed by a service technician.



Use Technical Manuals for Actual Service

This technical manual was written for you—an experienced service technician. Keep it in a permanent binder in the shop where it is handy. Read it when you need to know correct service procedures or specifications.

Some features of this manual:

- Inside front cover - "Table of Contents".
- Section 1 - Contents, safety information, general specifications and general services.
- Sections 1 through 43 - Removal, repair, testing (components removed), installation, and adjustment.
- Section 90 - Detailed explanation of system operation, diagnosis, visual inspection, testing, and adjustments.
- Specifications are listed and illustrated at the end of each section.

MAINTENANCE WITHOUT ACCIDENT WORK SAFELY



T27999N

 This safety alert symbol identifies important safety messages in this manual and on the feller-buncher. When you see this symbol, be alert to the possibility of personal injury and carefully read the message that follows.

**EVERY EMPLOYER HAS A
SAFETY PROGRAM. KNOW
WHAT IT IS!**

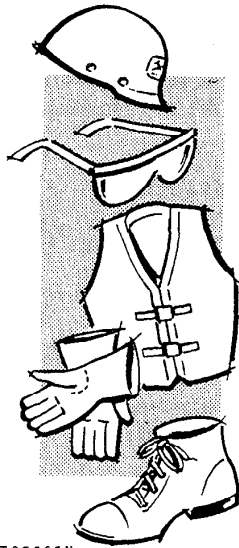

T27501N

See your shop supervisor for specific instructions on a job, and the safety equipment required.

For instance, you may need: Hard hat, safety shoes, safety goggles, heavy gloves, reflector vest, ear protectors, respirator.

Litho in U.S.A.

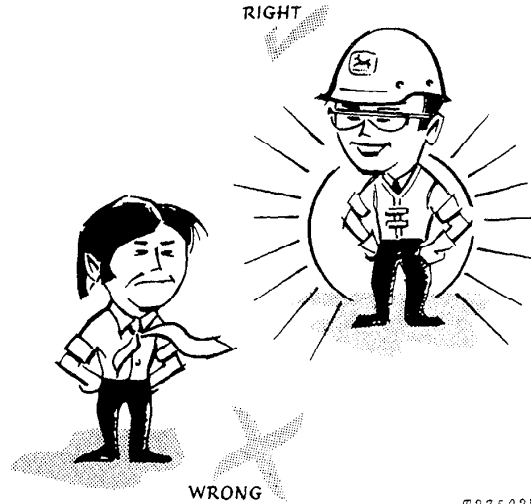

BE ALERT!

Plan ahead. Work safely. Know how to use a first-aid kit and a fire extinguisher. Know where to get aid.

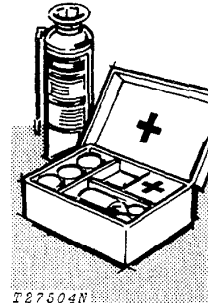

T27504N

Maintenance Area

Make sure the maintenance area has enough ventilation.

Keep the maintenance area CLEAN AND DRY. Oily and wet floors are slippery. Greasy rags are a fire hazard. Wet spots are dangerous when working with electrical equipment.

Keep starting aids in a cool, well-ventilated place, out of reach of unauthorized personnel.

MAINTENANCE WITHOUT ACCIDENT

AVOID FIRE HAZARDS -

Fuel Is Dangerous!

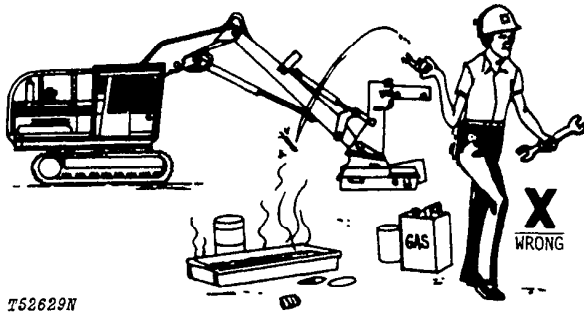

Do not smoke while putting fuel in the fuel tank.
Do not smoke while working with material that will start on fire easily.

Stop the engine before filling the fuel tank.
If the engine is hot, use care when putting fuel in the fuel tank.

Do not use gasoline or diesel fuel for cleaning parts.
Use solvents that will not start on fire.

Battery Gas Is Highly Flammable!

When charging batteries, be sure there is enough ventilation.



Do not check the battery charge by putting metal objects across the posts.

Do not let sparks or open flame near batteries.
Do not smoke near battery.

Flame Is Not a Flashlight!

NEVER USE OPEN FLAME AROUND THE MACHINE.

KNOW WHERE FIRE EXTINGUISHERS ARE KEPT!

UNDER ALL MAINTENANCE CONDITIONS -

Do not work on the equipment unless you are approved to do so. Then be sure you know the safe and correct procedure.

Never work on equipment while it is being operated.

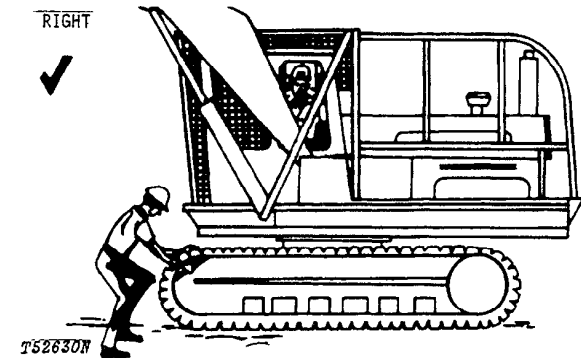

When the engine is running, avoid working on equipment.

If you must work on the machine with the engine running, ALWAYS USE TWO service technicians. One must be at the controls. The other must be within sight of the operator.

KEEP HANDS AWAY FROM MOVING PARTS.

Put a support under all raised equipment.

Never work under a raised shear.

Lower the shear to the ground.

If the machine is on a slope, use blocks to hold it in place.

Do not lift heavy parts by yourself. Use hoisting equipment for this.

TAKE CARE! WATCH OUT FOR OTHER PEOPLE IN THE AREA.

When drilling, grinding, or hammering metal, wear safety glasses.

BE CAREFUL DURING SERVICE AND REPAIR

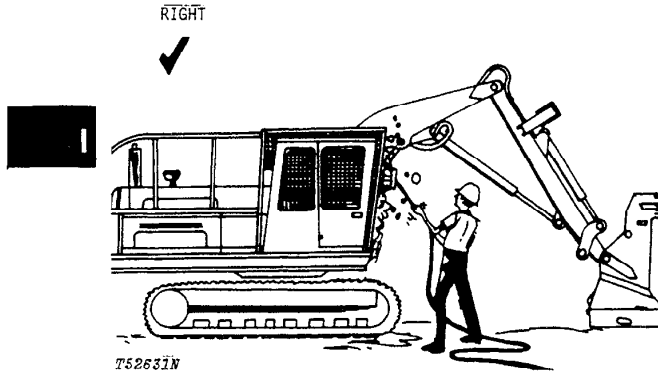

Keep ALL equipment free of dirt and oil.

Clean oil, grease, mud, ice or snow from the operator's station, steps and hand rails.

When getting the engine ready for storage, remember that inhibitor changes easily into gas and is dangerous. After adding the inhibitor, seal and tape openings. When you are not using the inhibitor, keep the can tightly closed.

Do not remove the radiator cap unless you can hold your hand on the radiator tank. First, loosen the cap slowly to the stop. Then release all pressure in the cooling system before removing the cap.

Check the exhaust system regularly for leaks.

Release hydraulic pressure before working on the hydraulic system. Stop the engine. Lower the shear to the ground. Move the control levers until the boom and shear do not move.

When checking hydraulic pressure, be sure to use the correct test gauge.

Before working on the fuel system, close the fuel shutoff valve.

Before working on the electrical system, or making a major overhaul, disconnect the batteries.

Before working on the hydraulic system release hydraulic pressure. Remove the hydraulic reservoir filler cap slowly. Open the diffuser vent.

KNOW EQUIPMENT IS READY!

All parts must be in good condition and fastened in place.

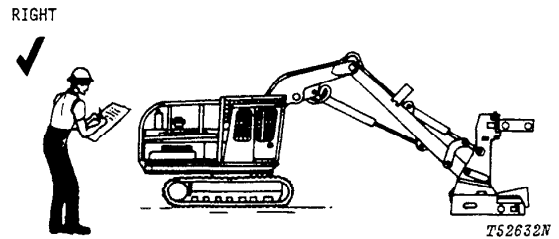

Carefully inspect all systems for leaks.

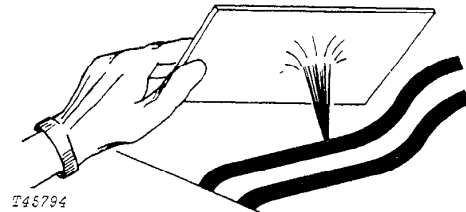

Use a piece of cardboard or wood, rather than hands, to search for suspected leaks.

Escaping fluid under pressure can penetrate the skin.

If injured by escaping fluid, see a doctor at once.

Group III

GENERAL SPECIFICATIONS

(Specifications and design subject to change without notice. Wherever applicable, specifications are in accordance with SAE Standards. Except where otherwise noted, these specifications are based on a unit equipped with Rome Tree Shear and standard equipment.)

Power (at 2400 engine rpm):	SAE	DIN
Gross	141 hp (105.1 kW)	
Net	131 hp (97.7 kW)	133 PS

Net engine flywheel power is for an engine equipped with fan, air cleaner, water pump, lubricating oil pump, fuel pump, alternator, and muffler. The gross engine power is without fan. Flywheel power ratings are under SAE standard conditions of 500 ft. (152 m) altitude and 85°F (29°C) temperature, and DIN 6270 conditions (non-corrected). No derating is required up to 10,000 ft. (3 000 m) altitude.

Engine: John Deere turbocharged diesel, vertical 6-cylinder, valve-in-head, 4-stroke cycle.

Bore and stroke 4.25x4.75 in. (108x121 mm)
 Piston displacement 404 cu. in. (6 620 cm³)
 Compression ratio 15.5 to 1
 Maximum torque

 @ 1600 rpm 375 lb-ft (508 Nm) (51.8 kg-m)
 NACC or AMA (U.S. Tax) horsepower 43.3
 Lubrication Pressure system w/full-flow filter
 Cooling . Pressurized w/thermostat and fixed bypass
 Fan Suction
 Air cleaner w/restriction indicator Dry
 Electrical system 12 volt w/alternator
 Batteries (2) 12 volt . Reserve capacity: 420 minutes

Hydraulic System:

Two open-center pumps mounted in tandem are coupled directly to the flywheel.
 Total flow is 84 gpm (5.3 L/s) at rated engine rpm.
 System operating pressure is 2500 psi (17 238 kPa) (175.7 kg/cm²).

Relief valves:

Boom (2)	3000 psi (20 685 kPa)	(210.9 kg/cm ²)
		3750 psi (25 856 kPa)
		(263.6 kg/cm ²)
Crowd (2)	3000 psi (20 685 kPa)	(210.9 kg/cm ²)
Tilt (2)	3000 psi (20 685 kPa)	(210.9 kg/cm ²)
Clamps (2)	3000 psi (20 685 kPa)	(210.9 kg/cm ²)
Shear (1)	3000 psi (20 685 kPa)	(210.9 kg/cm ²)

Oil filtration Three 10 micron filter elements in return lines

Cylinders	Bore	Rod Diameter
Boom (2)	5 in. (127 mm)	2.75 in. (70 mm)
Crowd and tilt	5.5 in. (140 mm)	3.25 in. (83 mm)

All cylinders have phenolic wear rings. Boom and crowd cylinders have a built-in hydraulic cushion at each end of the stroke. Tilt cylinder has hydraulic cushion at rod end. Full-frontal hydraulic oil cooler is in front of engine coolant radiator.

Swing Mechanism:

Swing 360-degree, continuous
 Turntable bearing Single row, ball.
 Case-hardened ring and pinion gears run in lubricant.

Undercarriage:

Propel motors (one for each track) ... High-torque 2-speed hydraulic motors with planetary drives. Wet multiple-disk brakes automatically release while propelling, and apply when stationary. Independent drive to each track permits counter-rotation.
 Undercarriage, car body, and track frame ... Each track frame is a formed, reinforced U-channel. Track frames are joined by reinforced boxed car body with swing bearing mount.
 A full-length combination chain guide and track support keep the rollers on the track chain and help prevent track shoe bending. Track motors and plumbing are completely enclosed to prevent damage.

Track Rollers and Idlers:

9 rollers and 1 idler per track. All rollers and idlers have metal-faced seals. Idlers have heavy-duty spring recoil mechanisms. Through-hardened steel slides support and guide upper track.

Track Shoes:	Ground Contact	Ground Pressure
Width	Shoes	
24 in. (608 mm)	Triple open-center semi-grousers	6136 sq. in. (39 577 cm ²) 8.0 psi (55.2 kPa) (0.56 kg/cm ²)
24 in. (608 mm) (optional)	Single-bar open-center	6136 sq. in. (39 577 cm ²) 8.0 psi (55.2 kPa) (0.56 kg/cm ²)
30 in. (762 mm) (optional)	Triple open-center semi-grousers	7670 sq. in. (49 472 cm ²) 6.4 psi (44.1 kPa) (0.45 kg/cm ²)

Track adjustment Hydraulic

Cab:

Steel, with urethane soundproofing on ceiling and walls and cushioned neoprene floor mat. Safety glass on all sides and top. Front and rear windows open. Front window is removable.

Seat:

Fully adjustable, foam rubber cushioned seat.

Controls:

Two levers for boom, crowd, tilt, and swing. Two levers control forward and rearward movement of right and left tracks. Two pedals control shear and clamps. Toggle switch controls tree accumulator.

Servicing and Vandal Protection:

Swingaway service doors expose built-in platforms for easy access to engine and hydraulic systems. Crank-operated bolts secure service doors. Cab and access covers to fuel tank, radiator, and air filters lock with ignition key.

Operating Information:

Width	9 ft. 5-1/2 in. (2.88 m)
Swing speed	7 rpm
Gradability	70 percent
Travel (2-speed)	0 to 0.9 mph (1.45 km/h) 0 to 1.7 mph (2.74 km/h)

Rome Shear

Maximum cutting radius (from center of swing)	27 ft. 6 in. (8.38 m)
Minimum cutting radius (from center of swing)	12 ft. (3.66 m)
Total cutting area	1923 sq. ft. (178.6 m ²)
Lift at 25 ft. (7.62 m)	3000 lb. (1 361 kg)
Maximum tree butt diameter	20 in. (51 cm)
Base width	41 in. (1.04 m)
Top grab opening	48 in. (1.22 m)
Blade thickness	0.75 in. (19 mm)
Weight	4500 lb. (2 041 kg)

John Deere Shear:

Maximum tree radius (from center of swing)	27.6 ft. (8.4 m)
Minimum cutting radius (from center of swing)	13.9 ft. (4.25 m)
Total cutting area	625 sq. ft. (58.1 m ²)
Lift at 25 ft.	3300 lb. (1 485 kg)
Maximum tree butt diameter	18 in. (46 cm)
Top grab opening	19 in. (48 cm)
Blade thickness	0.625 in. (16 mm)
Weight	3400 lb. (1 530 kg)

Capacities:

	U.S.	Imp.	Liters
Fuel tank	60 gal.	50.0 gal.	227.1
Cooling system	11.25 gal.	9.4 gal.	42.6
Engine lubrication	18 qt.	15.0	17.0
Engine lubrication, including filter	20 qt.	16.7 qt.	18.9
Hydraulic system	80 gal.	66.7 gal.	302.8
Planetary propel drive	10 qt.	8.3 qt.	9.4
Swing drive	8 qt.	6.7 qt.	7.5

Additional Standard Equipment:

- Electric hour meter
- Alternator charge indicator light
- Hydraulic oil filter pressure warning light
- Engine coolant temperature gauge
- Fuel gauge
- Hydraulic oil temperature gauge
- Engine oil pressure gauge
- Key switch
- Cold weather starting aid
- Horn
- Deluxe seat
- Positive-position hand throttle
- Counterweight 4200 lb. (1 906 kg) each
- Cab with heater and soundproofing

Operating weight w/boom and Rome shear

49,000 lb. (22 226 kg)

Special Equipment:

- 2000 lb. (907 kg) counterweight
- 24 in. (609 mm) single-bar open-center grouser
- 30 in. (762 mm) triple open-center semigrousers
- Air conditioner-heater
- Defroster fan
- Engine coolant heater

JD693-B FELLER-BUNCHER OPERATING DIMENSIONS

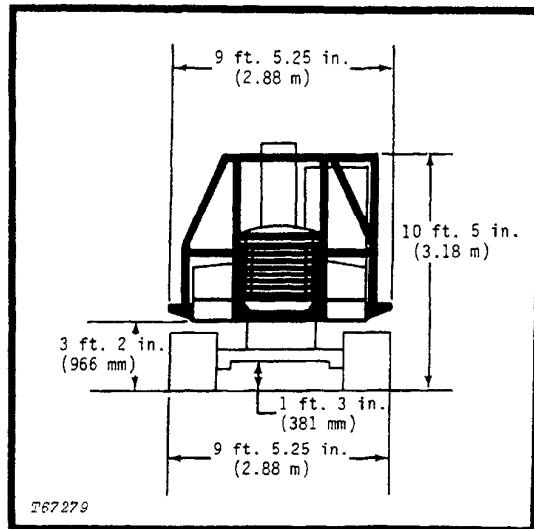
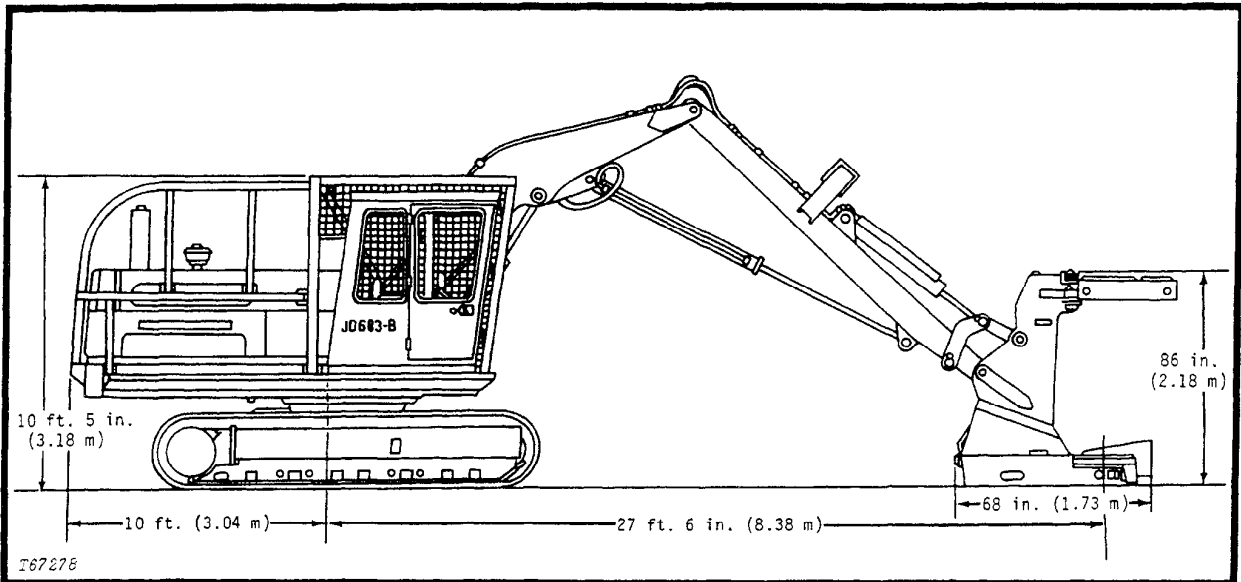

Group IV PREDELIVERY, DELIVERY, AND AFTER-SALE SERVICES

TEMPORARY FELLER-BUNCHER STORAGE

After receiving your feller-buncher from the factory and before putting the machine into temporary storage, perform the following checks.

1. Check battery electrolyte level. Charge the battery, if necessary.
2. Check engine coolant level. Keep coolant 1 in. (25.4 mm) below filler neck.
3. Fill fuel tank.
4. Check crankcase oil level. Oil must be between marks on dipstick after machine has been shut down for 10 minutes.
5. Release hydraulic pressure by stopping engine, lowering tree shear and operating control levers until the boom or shear does not move.

PREDELIVERY SERVICE

The service technician must carefully check and service the machine before the dealer delivers it to the customer. When the customer receives a machine that is correctly prepared, the customer is well-satisfied. For these reasons, correct predelivery service is very important to the dealer and the customer.

If adjustments are needed, see procedures in the After-Sale section.

Use the following list when getting a unit ready for delivery to the customer.

1. Crankcase Oil Level

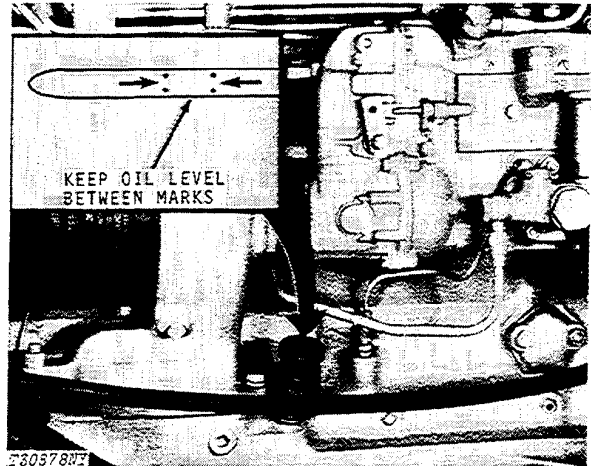

Fig. 1-Crankcase Dipstick

Check crankcase oil level when unit is on level ground and engine off.

Wait for 10 minutes after shutdown for oil to drain down.

Keep oil level between marks on dipstick.

Do not operate engine with oil level below bottom mark.

NOTE: There is a two-quart (1.89 L) difference between the bottom mark and the top mark on the dipstick.

Crankcase oil level checked Yes No

Oil added _____ qts. (L)

2. Hydraulic System Oil Level

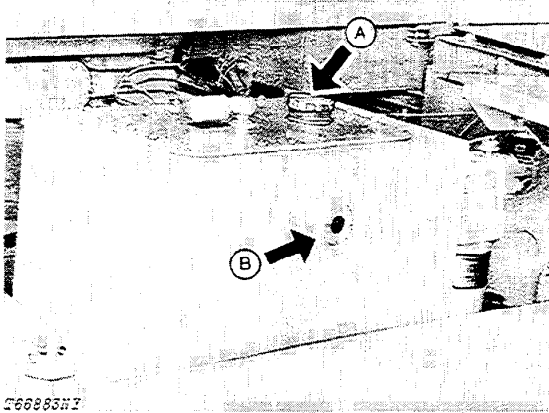

A—Reservoir Breather-Filler Cap B—Oil Level Window

Fig. 2-Hydraulic Reservoir

Check reservoir oil level when machine is on level ground.

Oil level must be to middle of oil level window when boom, secondary boom, and tilt cylinders are extended approximately halfway.

Add 2-1/2 gallons (9.5 L) of oil to raise oil level in reservoir 1" (25.4 mm).

If oil is needed, add oil specified on page I-V-2.

Oil level checked Yes No

Oil added _____ qts. (L)

3. Swing Gearbox Oil Level

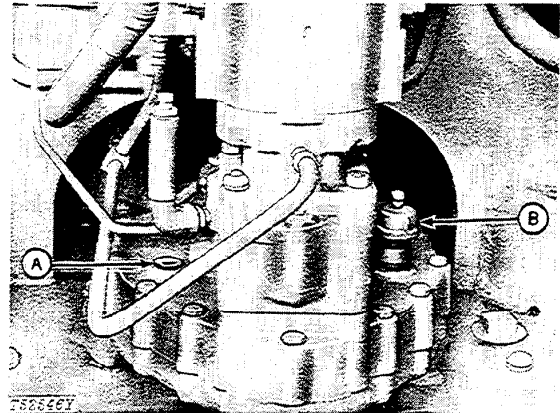

A—Check Plug B—Pipe Cap

Fig. 3-Swing Gearbox

Check oil level.

Remove check plug.

Oil must be to bottom of check plug hole. If not, remove pipe cap. Add oil specified on page I-V-2.

Install check plug and pipe cap.

Swing gearbox oil level checked Yes No

Oil added _____ qts. (L)

4. Track Gearbox Oil Level

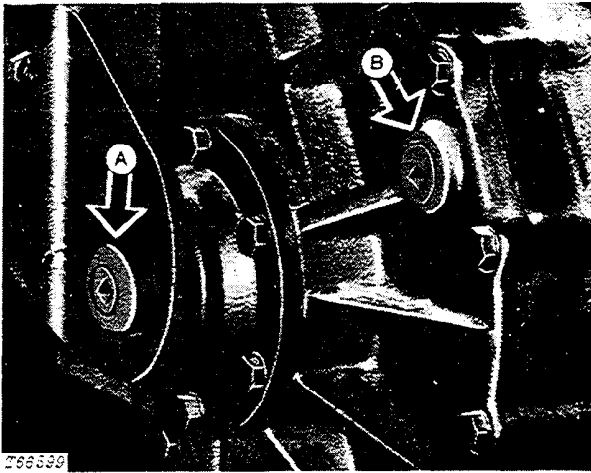

A—Check Plug B—Fill Plug

Fig. 4-Track Gearbox

Remove check plug.

Oil must be to check plug hole.

If not, remove fill plug. Add oil specified on page I-V-2.

Install fill plug and check plug.

Check other gearbox in same manner.

Track gearbox oil level checked	Yes	No
Oil added	_____ qts. (L)	

5. Track Rollers and Idlers Oil Level

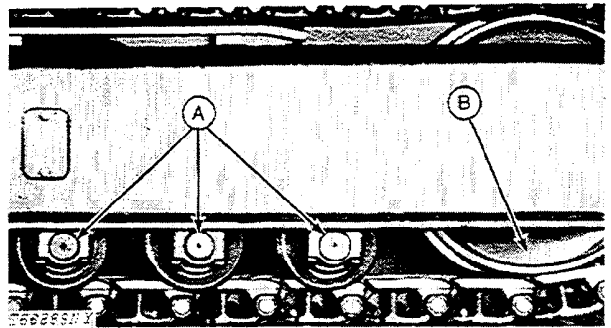

A—Track Rollers B—Front Idler

Fig. 5-Track Rollers and Idler

Check oil level of rollers and idlers.

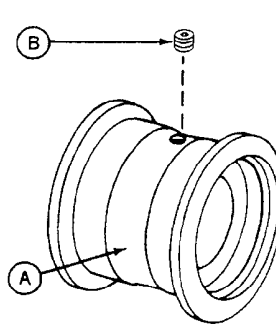

T52540

A—Roller
 B—Pipe Plug

Fig. 6-Track Roller

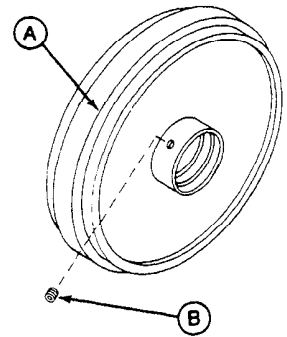

T52541

A—Idler
 B—Pipe Plug

Fig. 7-Idler

To check the oil level, turn the roller or idler so the pipe plug is at a 45° angle from the top. Remove the pipe plug. Oil must be to the bottom of the plug hole. If not, fasten a plastic tube to an oil can. Add oil through the plug hole. Use oil specified on page I-V-2.

Capacity of roller or idler is 11.5 ounces (0.34 L).

Put Loctite sealant on pipe plug. Install plug flush with surface.

Rollers and idlers oil level checked	Yes	No
Oil added	_____ qts. (L)	

6. House Lock Oil Level

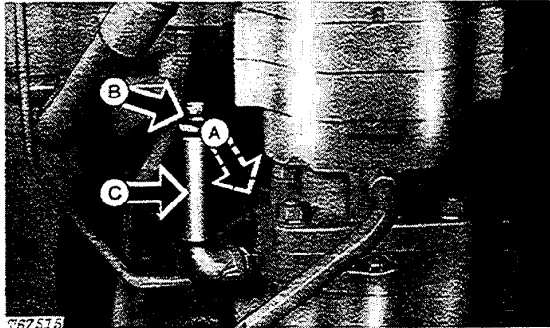

A—Pipe Plug C—Coupling
 B—Vent and Bushing

Fig. 8—House Lock Oil Level

Stop the engine. Remove the pipe plug (A). Oil must be at the bottom of the pipe plug hole. If not, remove the vent and bushing (B). Add oil specified on page I-V-2 through the coupling (C).

Install the pipe plug, vent, and bushing.

House lock oil level checked Yes No
 Oil added _____ qts. (L)

7. Propel Brake Oil Level

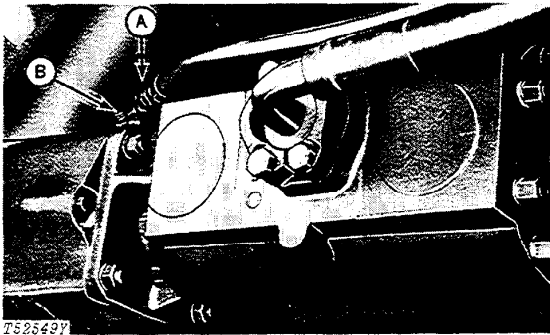

A—Pipe Plug B—Vent Tube

Fig. 9—Propel Brake

Check the oil level as follows:

1. Remove the cap screw from the propel motor cover. Pull the cover to the rear.
2. Remove the pipe plug. Oil must come out of the pipe plug hole.

Litho in U.S.A.

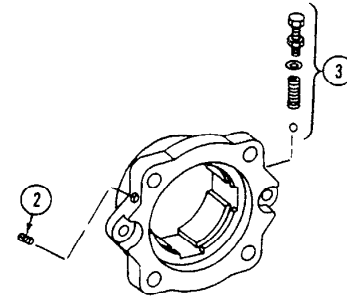

T63778N

Fig. 10—Propel Brake Oil Level

3. If not, remove the breather vent, washer, spring, and steel ball. Put these parts in a safe place. Add oil specified on page I-V-2.

4. Install all parts.

IMPORTANT: If the breather vent is dirty, flush it with fuel oil or solvent. Use compressed air to clean the breather vent.

Propel brake oil level checked Yes No
 Oil added _____ qts. (L)

8. Pre-Cleaner

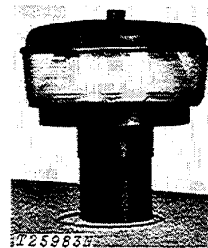

Fig. 11—Pre-Cleaner

Check pre-cleaner bowl. Clean it, if necessary.

Pre-cleaner checked Yes No

9. Air Cleaner

Check air filter indicator light. If the indicator light glows red, clean primary element. Install new primary and safety elements, if necessary.

Air cleaner checked Yes No

10. Air Intake Hoses

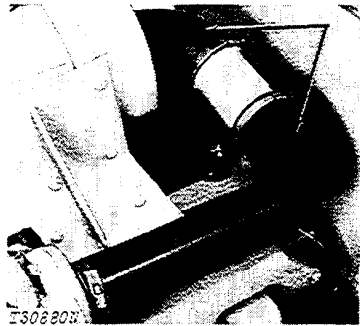

Fig. 12-Air Intake Hoses

Check hose clamps. Tighten, if necessary. Inspect hoses for cracks.

Air intake hoses checked Yes No

11. Radiator

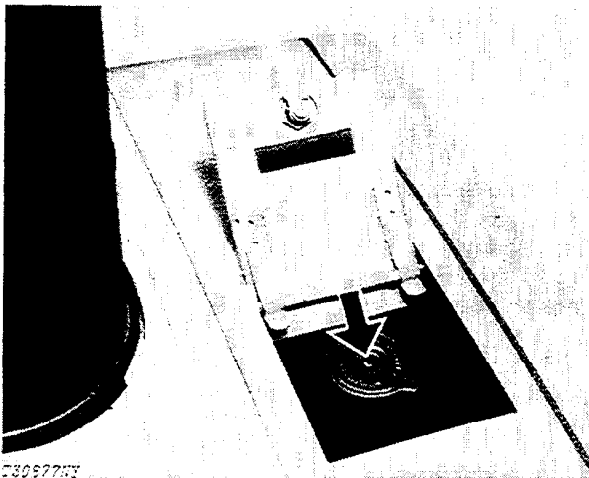

Fig. 13-Radiator Cap

CAUTION: Do not remove the radiator filler cap unless you can hold your hand on the radiator tank. First, loosen the cap slowly to the stop. Then release all pressure in the cooling system before removing the cap.

Check the coolant level. Keep the level 1 in. (25 mm) below the bottom of the filler neck when the engine is cold.

Use clean water for warm weather. Use a solution of 50% clean water and 50% permanent antifreeze (ethylene glycol with approved rust inhibitor) for cold weather.

DO NOT overfill the radiator.

Tighten the filler cap.

Check for leaks or loose connections. Clean radiator fins, if necessary.

Coolant level checked Yes No

12. Batteries

Check the electrolyte level of the batteries. If distilled water is not available, use clean soft water. Do not use hard water. Remove dirt from the top of the batteries with a damp cloth. Put petroleum jelly on terminals.

IMPORTANT: Never add water to the batteries in freezing weather unless the engine will be run 2 or 3 hours.

Check battery connections.

Punch date code on batteries.

Batteries checked Yes No

13. Fuel Filters

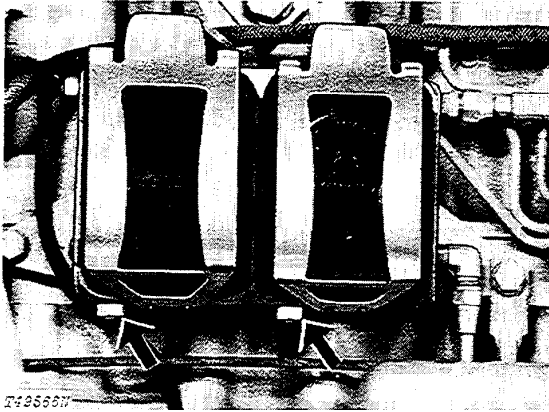

Fig. 14-Fuel Filter Drain Screws

Check fuel filters. Drain sediment, if necessary.

Loosen drain screws on bottom of fuel filters. Allow all water and sediment to drain. Tighten drain screw.

Remove air from the fuel system. See page I-IV-28.

Fuel filters checked Yes No

14. Fuel Supply Pump Sediment Bowl

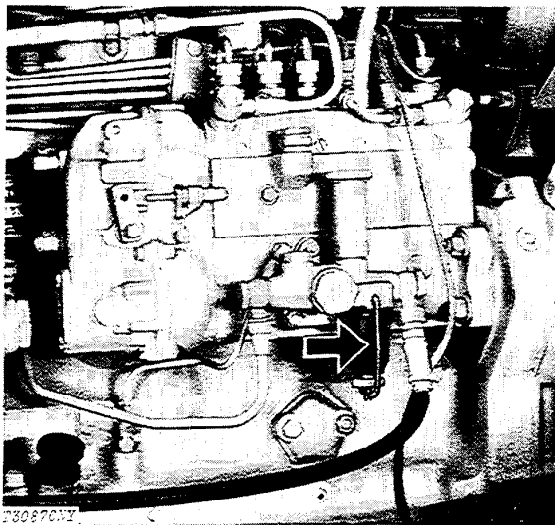

Fig. 15-Fuel Supply Pump Sediment Bowl

Remove fuel supply pump sediment bowl by releasing clamp from pump body.

Remove filter screen from inside bowl. Clean it with diesel fuel.

Clean sediment bowl. Install screen.

Install sediment bowl.

Remove air from fuel system. See page I-IV-28.

Sediment bowl checked Yes No

15. Fan Belt Tension

Check the tension of the fan belts.

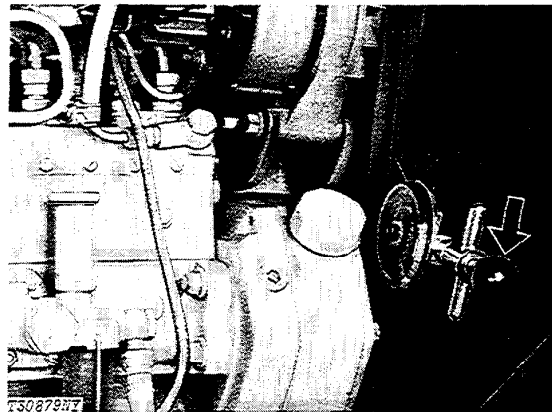

Fig. 16-Strand Tension Gauge

Strand tension gauge: Immediately after the engine stops (run the engine 5 minutes or more), check the belt tension. If strand tension is less than 50 lb. (223 N), let the engine cool 10 to 15 minutes. Then make tension 90 lb. (400 N). Check the front belt only.

Tension tester: A force of 20 lb. (89 N) halfway between the pulleys must move the belt 3/4 in. (19 mm).

Adjustment: Loosen the alternator bracket and adjusting cap screws.

**Thank you very much
for your reading.**

Please Click Here

**Then Get More
Information.**