

John Deere JD401-B Tractor and Loader

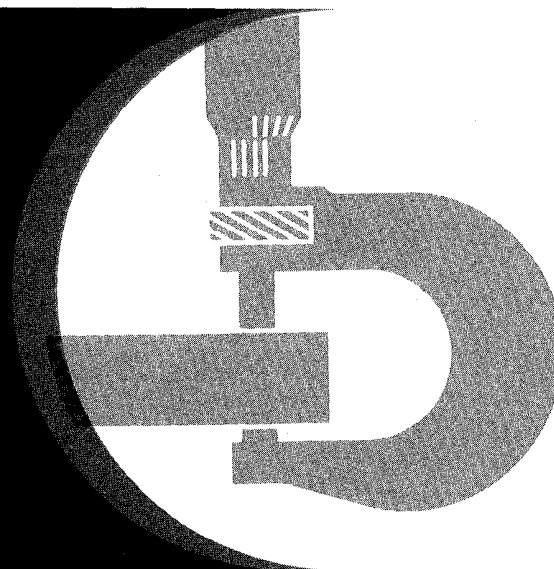

TECHNICAL MANUAL

TM-1091

Litho in U.S.A. (T) (Revised)

JD401-B Tractor and Loader

Technical Manual

TM-1091 (Jan-79)

CONTENTS

- Section 10 - GENERAL
 - Group 5 Specifications
 - Group 10 Predelivery, Delivery, and After-Sale Services
 - Group 15 Lubrication
- Section 20 - ENGINE
 - Group 5 Engine Removal and Installation
 - Group 10 Basic Engine
 - Group 15 Engine Lubrication System
 - Group 20 Engine Cooling System
 - Group 25 Fuel System
 - Group 30 Speed Control Linkage
 - Group 35 Air Intake System
 - Group 40 Specifications and Special Tools
- Section 30 - ELECTRICAL SYSTEM
 - Group 5 Batteries
 - Group 10 Charging System
 - Group 15 Starting System
 - Group 20 Ignition System
 - Group 25 Gauges and Switches
 - Group 30 Specifications and Special Tools
- Section 40 - POWER TRAIN
 - Group 5 Clutch Assemblies
 - Group 10 Transmission
 - Group 15 Reverser
 - Group 20 PTO Systems
 - Group 25 Differential and Parking Brake
 - Group 30 Final Drives
 - Group 35 Specifications and Special Tools
- Section 50 - HYDRAULIC SYSTEM
 - Group 5 Transmission Pump
 - Group 10 Main Hydraulic Pump
 - Group 15 Reverser Clutch Control Valve
 - Group 20 Independent PTO
 - Group 25 Pressure Control Valve
 - Group 30 Power Steering Valve
 - Group 35 Brake Valve
 - Group 40 Loader Control Valve
 - Group 45 Selective Control Valve
 - Group 50 Rockshaft System
 - Group 55 Miscellaneous Hydraulic Components
 - Group 60 Hydraulic Cylinders
 - Group 65 Specifications and Special Tools
- Section 60 - MISCELLANEOUS COMPONENTS
 - Group 5 Manual Steering
 - Group 10 Front End Assembly
 - Group 15 Loader Frame, Boom and Bucket
 - Group 20 Three-Point Hitch
 - Group 25 Specifications and Special Tools
- Section 70 - SYSTEM TESTING
 - Group 5 General Information
 - Group 10 Engine
 - Group 15 Electrical System
 - Group 20 Power Train
 - Group 25 Hydraulic System
 - Group 26 Hydraulic System (Analyzer)
 - Group 30 Miscellaneous Components
 - Group 35 Specifications and Special Tools

Index

The specifications and design information contained in this manual were correct at the time this machine was manufactured. It is John Deere's policy to continually improve and update our machines. Therefore, the specifications and design information are subject to change without notice. Wherever applicable, specifications and design information are in accordance with SAE and ICED standards.

Copyright 1973
DEERE & COMPANY
Moline, Illinois
All rights reserved

INTRODUCTION

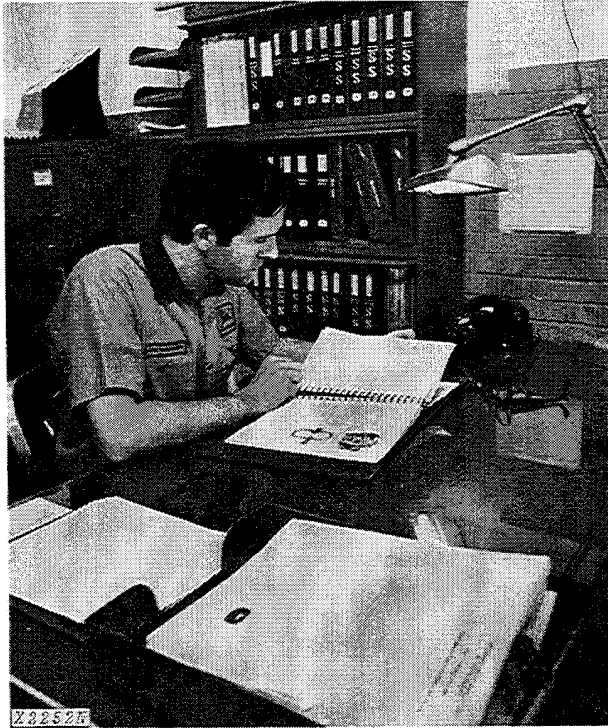

Use FOS Manuals for Reference

This technical manual is part of a twin concept of service:

The two kinds of manuals work as a team to give you both the general background and technical details of shop service.

•FOS Manuals—for reference

Fundamentals of Service (FOS) Manuals cover basic theory of operation, *fundamentals* of trouble shooting, *general* maintenance, and *basic* types of failures and their causes. FOS Manuals are for training new personnel and for reference by experienced technicians.



When a service technician should refer to a FOS Manual for more information, a FOS symbol like the one at the left is used in the TM to identify the reference.

•Technical Manuals—for actual service

Technical Manuals are concise service guides for a specific machine. Technical manuals are on-the-job guides containing only the vital information needed by an experienced service technician.



Use Technical Manuals for Actual Service

This technical manual was planned and written for you—an experienced service technician. Keep it in a permanent binder in the shop where it is handy. Refer to it whenever in doubt about correct service procedures or specifications.

Some features of this manual:

- Inside front cover - "Table of Contents" and "Maintenance Without Accident".
- Section 10 - General specifications and services.
- Sections 20 through 60 - Removal, repair, testing (components removed), installation, and adjustment.
- Section 70 - Detailed explanation of system operation, diagnosis, visual inspection, testing, and adjustments.
- Specifications grouped and illustrated at the end of each section.
- Inside rear cover—Index.

MAINTENANCE WITHOUT ACCIDENT WORK SAFELY



T27999

 This safety alert symbol identifies important safety messages in this manual and on the tractor. When you see this symbol, be alert to the possibility of personal injury and carefully read the message that follows.

**EVERY EMPLOYER HAS A
SAFETY PROGRAM. KNOW
WHAT IT IS!**

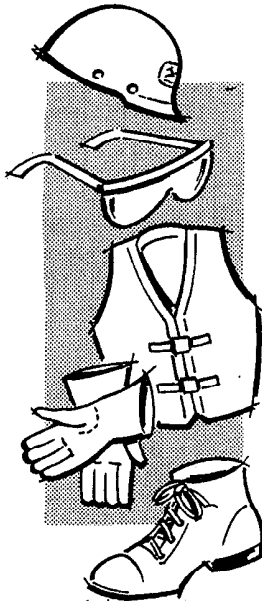

T27501N

Consult your shop foreman for specific instructions on a job, and the safety equipment required.

For instance, you may need: Hard hat, safety shoes, safety goggles, heavy gloves, reflector vests, ear protectors, respirators.

Litho in U.S.A.



T27502N

BE ALERT!

Plan ahead—work safely—know how to use a first-aid kit and a fire extinguisher—and where to get aid and assistance.

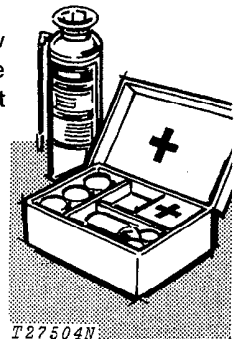

T27504N

Maintenance Area

Make sure the maintenance area is adequately vented.

Keep maintenance area **CLEAN AND DRY**. Oily and wet floors are slippery; greasy rags are a fire hazard; wet spots are dangerous when working with electrical equipment.

Store starting aids in a cool and well-ventilated place, out of the reach of unauthorized personnel.

MAINTENANCE WITHOUT ACCIDENT

AVOID FIRE HAZARDS—

Fuel Is Dangerous!

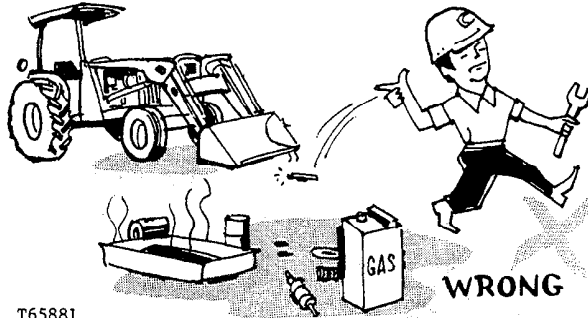

T65881

Don't smoke while refueling.

Don't smoke while handling highly flammable material.

Engine should be shut off when refueling.

Use care in refueling if the engine is hot.

Don't use open pans of gasoline or diesel fuel for cleaning parts. Good commercial, nonflammable solvents are preferred.

Battery Gas Is Highly Flammable!

Provide adequate ventilation when charging batteries.



T27508N

Don't check battery charge by placing metal objects across the posts.

Don't allow sparks or open flame near batteries.

Don't smoke near battery.

Flame Is Not a Flashlight!

NEVER USE OPEN FLAME AROUND THE MACHINE.

KNOW WHERE FIRE EXTINGUISHERS ARE KEPT!

UNDER ALL MAINTENANCE CONDITIONS—

Do not perform any work on the equipment unless authorized to do so. Then be sure you know the safe and proper procedure.

Follow recommended procedures.

Never service the equipment while it is being operated.

Avoid working on equipment with the engine running.

RIGHT

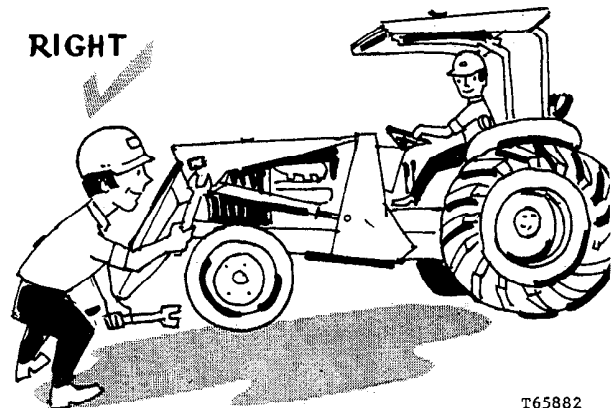

T65882

If it is necessary to make checks with the engine running, **ALWAYS USE TWO** service technicians—one, the operator, at the controls, the other checking within sight of the operator.

KEEP HANDS AWAY FROM MOVING PARTS

Support all raised equipment.

Never work under raised bucket.

Lower bucket to ground.

If the machine is on an incline, block it securely.

Use hoisting equipment for lifting heavy parts.

TAKE CARE! WATCH OUT FOR OTHER PEOPLE IN THE VICINITY

Wear safety glasses when drilling, grinding, or hammering metal.

SERVICING PRECAUTIONS

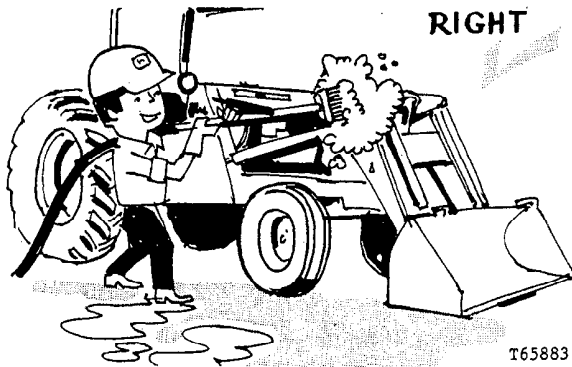

Keep ALL equipment free of dirt and oil.

Be sure to clean any oil, grease, mud, ice, or snow from floor of operator's compartment and stepping points.

When preparing the engine for storage, remember that inhibitor is volatile and therefore dangerous. Seal and tape openings after adding the inhibitor. Keep container tightly closed when not in use.

Don't remove the radiator cap until coolant temperature is below the boiling point. Then loosen cap slowly to the stop to relieve pressure before removing.

Periodically check exhaust system for excessive leakage.

Relieve hydraulic pressure before working on hydraulic system: shut off engine, lower bucket to ground, and move control levers and steering wheel until no response is felt.

When checking hydraulic pressure, be sure to use the correct test gauge.

PRECAUTIONS DURING REPAIR

Before working on hydraulic system relieve hydraulic pressure.

Before repairing the electrical system, or performing a major overhaul, disconnect batteries.

KNOW EQUIPMENT IS READY!

Check guards, canopies, safety guards — all protective devices installed on the unit. Every one should be in place and secure.

CHECK IT OUT!

- GUARDS
- CANOPIES
- SHIELDS
- PROTECTIVE DEVICES
- ROLL-OVER PROTECTIVE STRUCTURES
- SEAT BELTS, ETC.

RIGHT

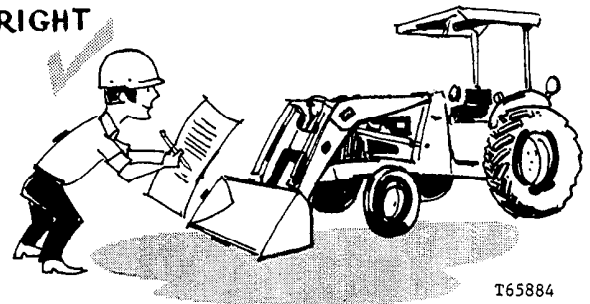

Carefully inspect equipment for visual defects—leaks in fuel, lubrication, and hydraulic systems. Do not search for pressurized fluid leaks with your hands. Use cardboard or wood to search for leaks.

Section 10 GENERAL

CONTENTS OF THIS SECTION

	Page		Page
GROUP 5 - SPECIFICATIONS		GROUP 15 - LUBRICATION	
General Machine Specifications	5-1	Oils and Greases	15-1
GROUP 10 - PREDELIVERY, DELIVERY, AND AFTER-SALE SERVICES			
Temporary Machine Storage	10-1		
Predelivery Service	10-1		
Delivery Service	10-12		
After-Sale Inspection	10-12		

Group 5 GENERAL MACHINE SPECIFICATIONS

(Specifications and design subject to change without notice. Wherever applicable, specifications are in accordance with ICED and SAE Standards. Except where otherwise noted, these specifications are based on a unit equipped with 14.9-24, 6 ply rating rear tires; 7.50/8.00-16, 6 ply rating front tires; 3/4 cu. yd. (0.57 m³) bucket; and standard equipment.)

Power (@ 2,500 engine rpm):

	SAE	DIN
Gross	66 hp (49.2 kW*)	
Net	62 hp (46.2 kW)	65.9 PS

Net engine flywheel power is for an engine equipped with fan, air cleaner, water pump, lubricating oil pump, fuel pump, alternator, and muffler. Gross engine power is without fan. Flywheel power ratings are under SAE standard conditions of 500 ft. altitude and 85°F temperature and DIN 70 020 standard conditions of 760 mm Hg barometer (sea level) and 20°C temperature.

*In the International System of Units (SI), power is expressed in kilowatts (kW).

Engine: John Deere, 4-cylinder diesel, valve-in-head, 4-stroke cycle

Bore and stroke

4.02x4.33 in.
(102x110 mm)

Piston displacement

219 cu. in.
(3588 cm ³)

Compression ratio

16.2 to 1

Maximum torque @ 1,300 rpm

160 lb-ft
(217 Nm) (22.1 kg-m)

NACC or AMA (U.S. Tax) horsepower	25.65
Main bearings	5
Lubrication	Pressure system with full flow filter
Cooling	Pressurized with thermostat and fixed bypass
Fan	Suction
Air cleaner	Dry
Electrical system	12 volt with alternator
Battery (12 volt) reserve capacity	110 minutes
Engine Clutch	Foot-operated, single 11 in. (279 mm; plate without reverser, 10 in. (254 mm) plate with reverser.

Transmission . . . Constant mesh, 8 forward speeds, 4 reverse with helical gears and sliding collars; mechanical shuttle. Optional hydraulic direction reverser provides 8 speeds forward and 8 reverse; hydraulic wet clutches, no clutching required.

Gear	Travel Speeds:			
	mph		km/h	
	Fwd.	Rev.	Fwd.	Rev.
1	1.3	1.6	2.1	2.6
2	1.9	2.2	3.1	3.5
3	2.9	3.3	4.7	5.3
4	4.0	4.7	6.4	7.6
5	5.3	6.3	8.5	10.1
6	7.6	9.0	12.2	14.5
7	11.2	13.5	18.0	21.7
8	15.7	18.7	25.3	30.1

Final Drives Inboard, planetary

Brakes ...Hydraulically-actuated, fully enclosed wet-disk. Self-equalizing. Foot-operated individually or simultaneously.

Steering Manual

Turning radius (brake applied) .. 10 ft. 7 in. (3.23 m)
Loader clearance circle, dia.

(brake applied) 35 ft. 6 in. (10.85 m)

Number of turns, far left to far right 3.3

Hydraulic System: Closed-center

Max pressure 2350 psi (162 bar)

Loader control 2-lever

Pump ... Piston, constant pressure, variable-displacement, 13 gpm (49 L/min) @ 2500 engine rpm

Hydraulic

Cylinders:	Bore	Stroke
Boom	2.25 in. (57 mm)	33.28 in. (845 mm)
Bucket	2.25 in. (57 mm)	24.36 in. (624 mm)
Cylinder rods.....	Ground, heat-treated, chrome-plated, polished	
Boom cylinder rods	1.5 in. (38 mm) dia.	
Bucket cylinder rods	1.25 in. (32 mm) dia.	

Tires:	Front	Rear
Turf	27-9.50-15, 6 ply rating, I1 Terra-tires 27-9.50-15, 10 ply rating, I1 Terra-tires	18.4-16A, 6 ply rating, R3
Utility	11L-15, 8 ply rating, F3 7.50/8.00-16, 6 ply rating F3	14.9-24, 6 ply rating, R4 14.9-24, 6 ply rating, R1 16.9-24, 6 ply rating, R3 17.5L-24, 8 ply rating, R4

Front Axle Swept-back, adjustable

Wheel Treads (dependent on tires and front axle):

Front 49 to 74 in. (1.25 to 1.88 m)

Rear 48 to 76 in. (1.22 to 1.93 m)

Dimensions:

Height to top of hood..... 4 ft. 7 in. (1.40 m)

Overall height to top of muffler... 6 ft. 7 in. (2.01 m)

Overall height to top of canopy .. 7 ft. 2 in. (2.18 m)

Overall width w/60 in. tread width 6 ft. 3 in. (1.90 m)

Overall length 15 ft. 11 in. (4.85 m)

Overall length w/3-point hitch..... 17 ft. (5.18)

Wheelbase..... 79.4 in. (2.02 m)

Ground clearance

(under front axle)..... 1 ft. 5 in. (430 mm)

Ground clearance, min. 11 in. (279 mm)

Capacities:

	U.S.	Liters
Cooling system	3 gal.	11.4
Fuel tank	19.5 gal.	73.8
Engine lubrication, including filter.....	6 qt.	5.7
Transmission-hydraulic system	10 gal.	37.9

Additional Standard Equipment:

- Oil pressure indicator light
- Alternator charge indicator light
- Coolant temperature gauge
- Key switch safety start
- Cushioned seat
- Vertical muffler with rain cap
- Transistorized voltage regulator
- Fenders
- Anti-freeze
- Two-position disk rear wheels
- 3/4 cu. yd. (0.57 m³) loader bucket
- Air cleaner restriction indicator
- Cold weather starting aid
- Rear PTO (continuous "live" or independent 540 rpm)
- Speed hour meter
- Horn

SAE Operating Weight 6280 lb. (2 849 kg)

DIMENSIONS

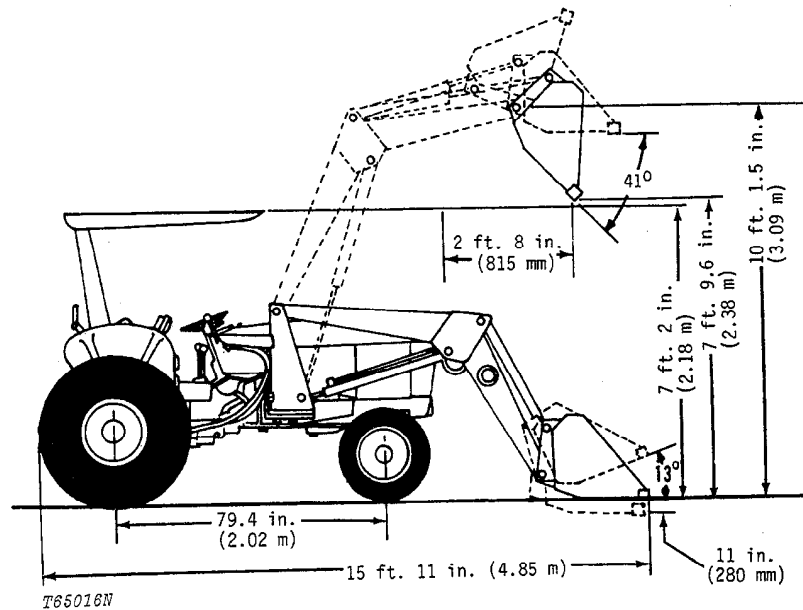

Special Equipment

- Batteries (2) reserve capacity: 220 minutes
- Cigar lighter
- Deluxe seat
- Differential lock
- Fixed front axle
- Foot throttle
- Front grille guard
- Fuel gauge
- Hydraulic direction reverser
- Lights
- Mid PTO (1,000 rpm "live," w/rear PTO)
- Muffler extension (vertical muffler)
- Parking brake
- Power steering
- Rear muffler
- Remote hydraulic cylinder
- ROPS and seat belt, w/ or w/o canopy
- Single or dual remote-cylinder control w/quick-connect couplers
- Swinging drawbar
- 3-inch seat belt
- 3-point hitch (Category 1 or 2 w/sway blocks and regular or short links)
- Tool box

LOADER SPECIFICATIONS

Buckets:	Nominal Heaped Capacity	Width
	3/4 cu. yd. (0.57 m ³)	73.8 in. (1.58 m)

Operating Information:

Breakout force	4000 lb. (17.92 kN) (1814 kg)
Lifting capacity, full height	2500 lb. (1134 kg)
Raising time to full height	5.1 sec.
Bucket dump time	2.9 sec.
Lowering time (power)	3.0 sec.
Rollback time	2.6 sec.
Float-down time	6.1 sec.
Minimum recommended rear ballast	2000 lb. (910 kg)

Group 10 PREDELIVERY, DELIVERY, AND AFTER-SALE SERVICES

TEMPORARY UNIT STORAGE

After receiving your unit from the factory and before putting the machine into temporary storage, perform the following checks and services.

For long term storage (over 30 days) information, consult your JD401-B operator's manual.

1. Check battery electrolyte level and charge the battery, if necessary.
2. Check engine coolant level. Maintain midway between the radiator core and filler neck.
3. Fill the fuel tank.
4. Check crankcase oil level. Oil must be between marks on dipstick after machine has been shut down for 10 minutes.
5. Relieve hydraulic pressure by stopping engine, lowering bucket and operating control levers and steering wheel until system fails to respond.
6. Reduce shipping pressure of all tires to the inflation pressure listed on page 10-10-2.

PREDELIVERY SERVICE

Because of the shipping factors involved, plus extra finishing touches that are necessary to promote customer satisfaction, proper predelivery service is of prime importance to the dealer and the customer.

Use the following list when preparing a unit for delivery to the customer.

1. Air Cleaner

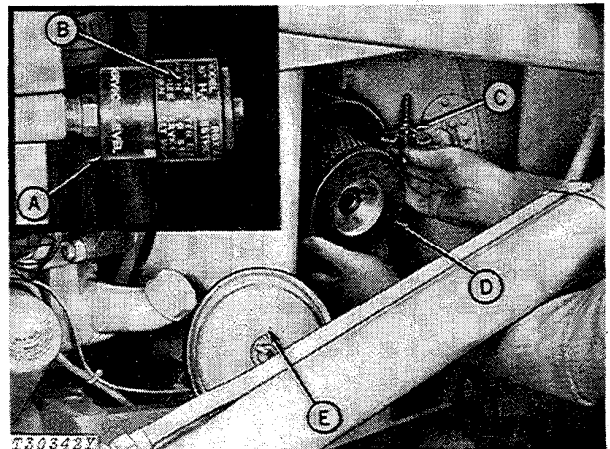

- A—Restriction Indicator
B—Red Signal
C—Wing Nut
D—Element
E—Cover

Fig. 1-Air Cleaner

Check air filter restriction indicator (A). If red signal can be fully seen, remove element (D) and clean. Install a new element if necessary.

Element checked Yes No

2. Radiator

Check engine coolant level.

CAUTION: Do not remove radiator filler cap unless the engine is cool. Then loosen the cap slowly to the stop to relieve pressure before removing the cap.

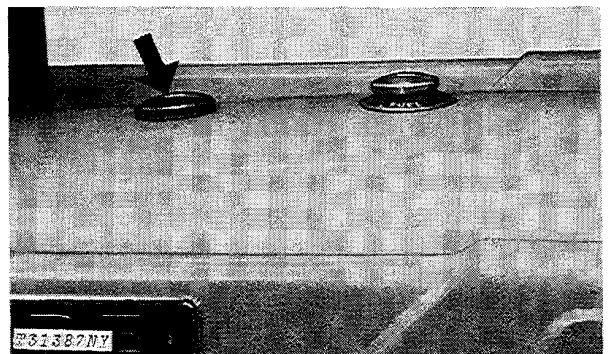

Fig. 2-Radiator Filler Cap

Maintain coolant level midway between the radiator core and the filler neck. If needed add clean soft water for warm weather, or a solution of 50% clean water and 50% ethylene glycol (permanent type antifreeze with approved rust inhibitor) for cold weather.

Check cooling system for loose connections and leaks.

Coolant level checked Yes No

3. Tire Pressure

Check tire pressure with an accurate gauge having 1 psi (0.07 bar) graduations.

Inflate tires according to the chart below.

FRONT TIRE INFLATION

Tire Size	Type	PR	Inflation Pressure		
			With Towed or Rear-Mounted Equipment	With Light Front-Mounted Equipment	With Heavy Front-Mounted Equipment
7.50/8.00-16	F-3	6	28 psi (1.9 bar)	32 psi (2.2 bar)	36 psi (2.5 bar)
27x9.50-15	I-1	6	35 psi (2.4 bar)	40 psi (2.8 bar)	Do not use
27x9.50-15	I-1	10	55 psi (3.8 bar)	60 psi (4.1 bar)	65 psi (4.5 bar)
11L-15	F-3	8	40 psi (2.8 bar)	40 psi (2.8 bar)	40 psi (2.8 bar)

REAR TIRE INFLATION

Tire Size	PR	Inflation Pressure		
		With Little Ballast or No Rear-Mounted Equipment	With Moderate Ballast or Light Rear-Mounted Equipment	With Maximum Ballast or Heavy Rear-Mounted Equipment
14.9-24	6	14 psi (1.0 bar)	16 psi (1.1 bar)	18 psi (1.2 bar)
16.9-24	6	18 psi (1.2 bar)	20 psi (1.4 bar)	22 psi (1.5 bar)
17.5L-24	8	24 psi (1.7 bar)	24 psi (1.7 bar)	24 psi (1.7 bar)
18.4-16A	6	14 psi (1.0 bar)	14 psi (1.0 bar)	Do not use

Tire pressure checked Yes No

4. Battery

Check battery electrolyte level. If distilled water is not available, use clean soft water. Avoid use of hard water. Remove foreign material from top of battery and coat terminals with petroleum jelly. Check vent holes in battery caps.

IMPORTANT: Never add water to battery in freezing weather unless engine will be run 2 or 3 hours.

Punch date code on battery.

Battery checked Yes No

5. Crankcase Oil Level

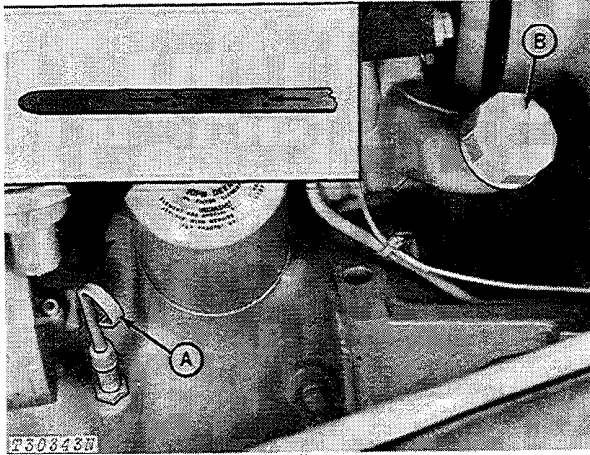

A—Dipstick B—Oil Filler Cap

Fig. 3-Crankcase Oil Level

Check crankcase oil level with machine on level ground. (Allow a minimum of 10 minutes for the oil to drain down before checking.) If oil level is at or below bottom mark on dipstick, add oil specified on page 10-15-1 to bring oil level to between marks on dipstick. Do not operate engine with oil level below the bottom mark.

Crankcase oil level checked	Yes	No
Oil added		qts. (L)

6. Transmission Oil Level

Check transmission-hydraulic oil level.

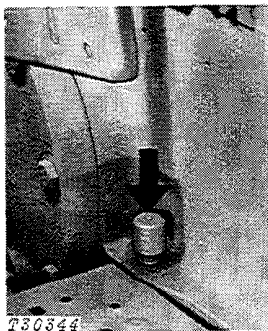

Fig. 4-Transmission-Hydraulic System Dipstick Resting On Top Threads

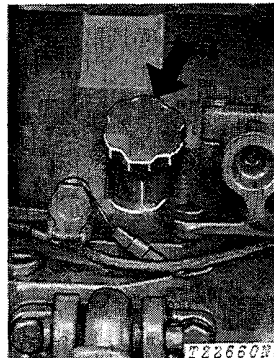

Fig. 5-Transmission-Hydraulic System Filler Cap

Run engine two to three minutes to fill oil circuits. Check oil level with machine on level ground, engine running at slow idle, rockshaft and any equipment lowered, reverser lever (if equipped) locked in neutral, parking brake engaged (if equipped), range shift lever in park, and clutch engaged. Remove dipstick and wipe off oil. Insert dipstick with cap resting on threads of tube (not screwed in place). If oil level is down to bottom mark on dipstick, add oil. Remove filler cap on rockshaft housing and add oil specified on page 10-15-1 to bring oil level to top mark on dipstick.

Oil level checked	Yes	No
Oil added		qts. (L)

7. Fuel Tank

Fill fuel tank with correct fuel. Check action of fuel gauge.

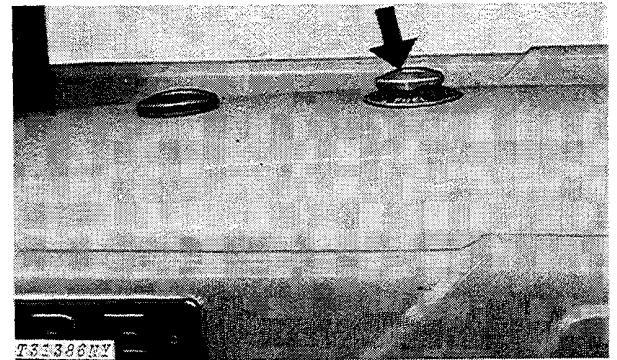
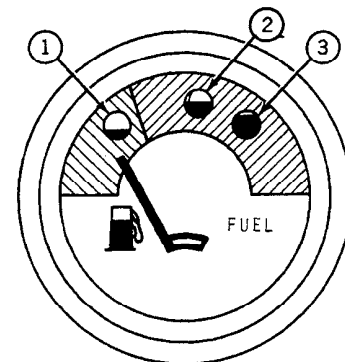

Fig. 6-Fuel Tank Filler Cap



T31392

1—Empty Tank

2—Half Full Tank

3—Full Tank

Fig. 7-Fuel Gauge

Fuel tank filled	Yes	No
Fuel gauge checked	Yes	No

8. Grease Fittings

All grease fittings were lubricated and checked before the unit left the factory. However, to insure customer satisfaction, check each fitting shown. Lubricate, if necessary, with John Deere Multi-Purpose Grease or an equivalent.

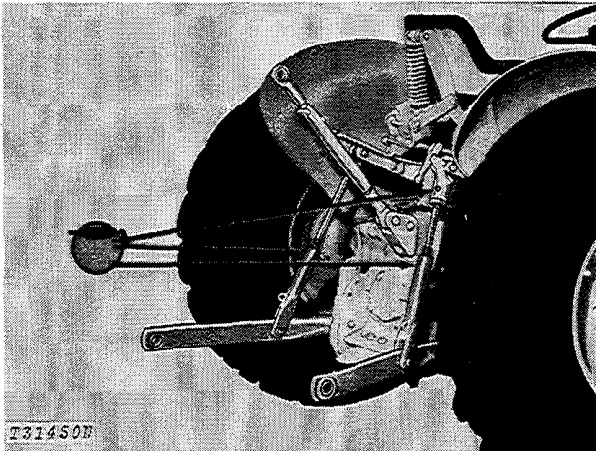

Fig. 8-3-Point Hitch (3 points)

Lubrication required Yes No

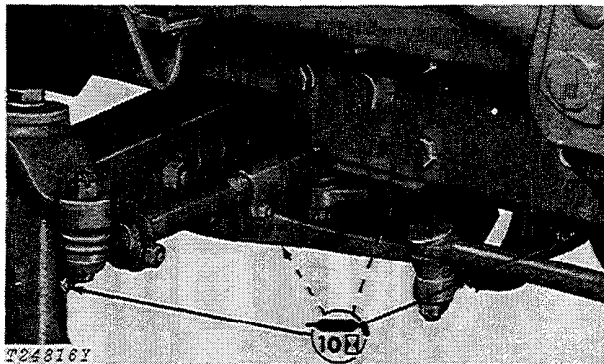

Fig. 9-Front Axle Pivot Points (4 points)

Lubrication required Yes No

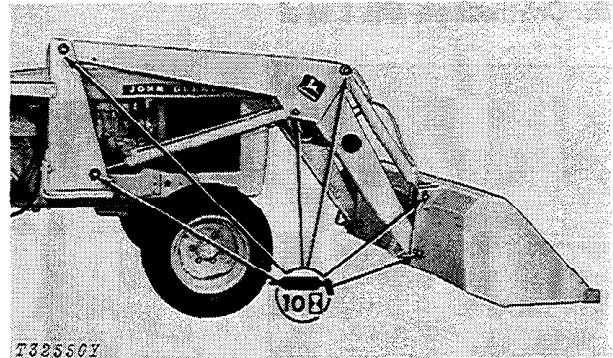

Fig. 10-Loader Pivot Points (12 points)

Lubrication required Yes No

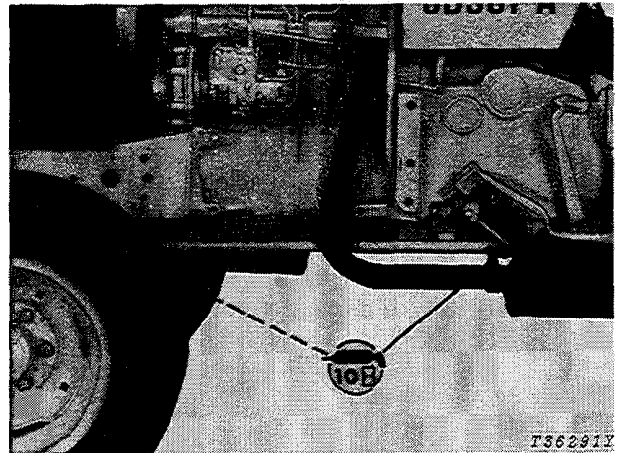

Fig. 11-Drag Links (2 points)

Lubrication required Yes No

9. Air Intake Hoses

Check clamps on hoses connecting air cleaner and engine. Tighten hose clamps where necessary. Inspect hoses for cracks.

Intake hoses checked Yes No

10. Alternator - Fan Belt Tension

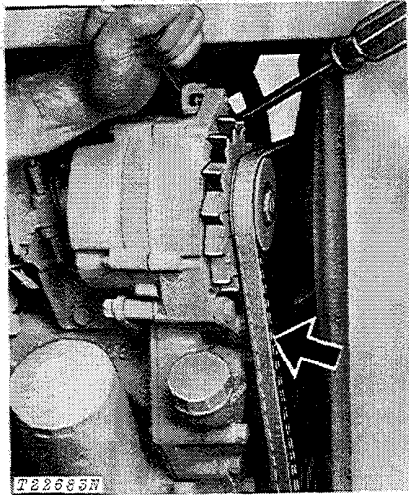

Fig. 12-Alternator - Fan Belt Tension

Check alternator-fan belt tension. Loosen the alternator bracket and adjusting cap screws. Apply outward force to the FRONT alternator frame until 20 lb. (9 kg) force on the belt midway between the pulleys will deflect the belt 3/4 inch (19 mm). If a tension gauge is used, strand tension must be 90 lb. (41 kg).

IMPORTANT: Do not pry on the rear of the alternator housing.

Belt tension checked Yes No

11. Engine Speeds

Check engine speeds.

Slow idle - 825 rpm

Fast idle - 2650 rpm hand throttle
2800 rpm foot throttle

If adjustment is needed, see page 10-10-18.

Engine speeds checked Yes No

12. Fuel Filter

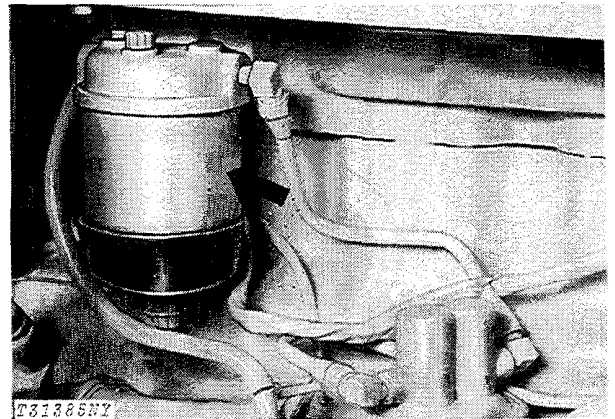

Fig. 13-Fuel Filter

Check fuel filter for sediment. Drain if necessary.

Fuel filter checked Yes No

13. Indicator Lights and Gauges

Check operation of indicator lights.

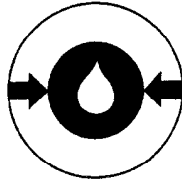

T22738

Fig. 14-Engine Oil Pressure Indicator Light

If light glows red when engine is running, stop engine immediately and determine cause.

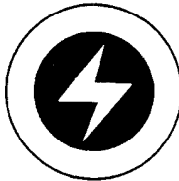

T22737

Fig. 15-Alternator Indicator Light

Light glows red when alternator is not charging. When light goes on with engine running, stop engine and determine cause.

Check operation of the engine coolant temperature gauge.

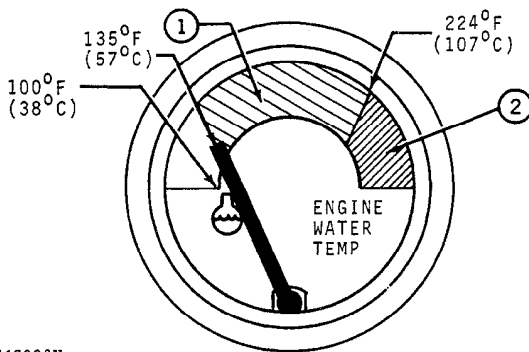

T43920N

1—Operating Range

2—Overheat Range

Fig. 16-Coolant Temperature Gauge

If the indicator hand goes into the red-orange zone, stop the engine. Check the cooling system.

NOTE: Fuel gauge is on page 10-10-3.

Indicator lights and gauges checked Yes No

14. Reverser

Check the reverser operation.

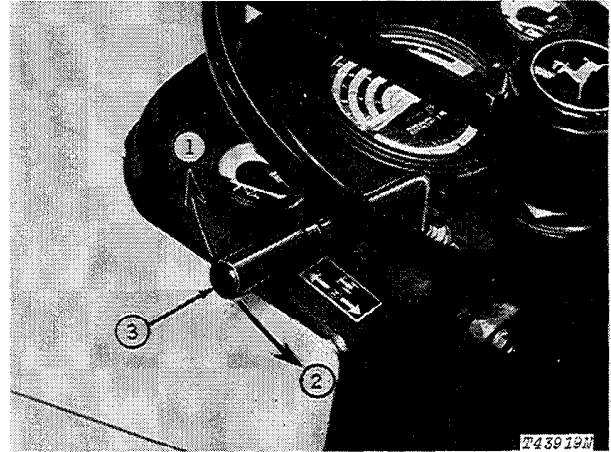

1—Forward

2—Reverse

3—Neutral

Fig. 17-Reverser Lever

The reverser unit allows the operator to change the direction of travel "on the go" without declutching or shifting gears.

Note and correct any reverser malfunctions.

See page 10-10-20 for reverser speed-of shift adjustment.

Reverser checked Yes No

15. Differential Lock

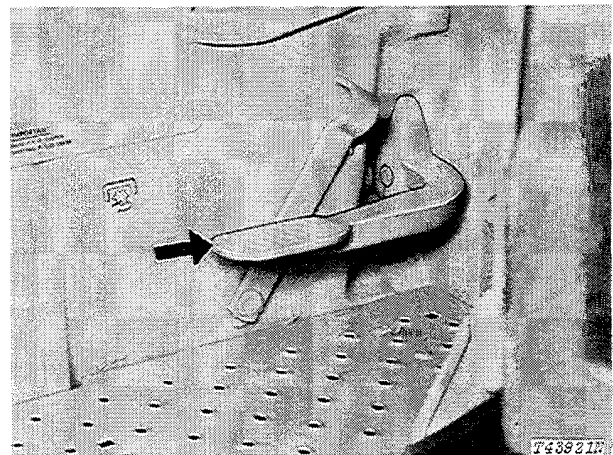

Fig. 18-Differential Lock Pedal

Check the differential lock operation.

While driving straight ahead, push down the differential lock pedal. Hold the pedal down. Turn the steering wheel slightly. There will be steering resistance if the differential lock is working correctly.

The differential lock will automatically disengage when the pedal is released if traction for both rear wheels is equal. Unequal traction will keep the lock engaged.

Differential lock checked Yes No

16. Transmission Shifting

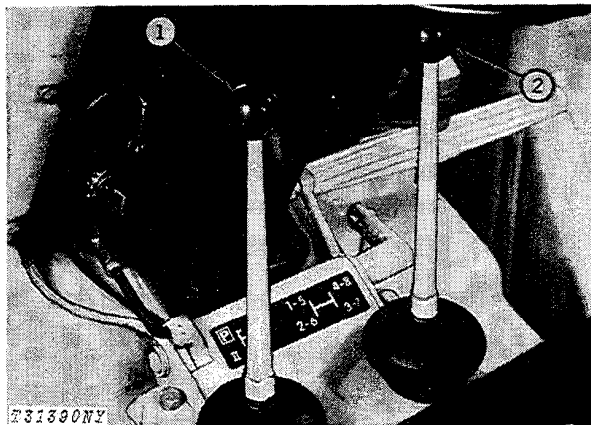

1—Range Shift Lever 2—Gear Shift Lever

Fig. 19-Transmission

Check the operation of the unit in all ranges and gears.

Correct any malfunctions.

Transmission shifting checked Yes No

17. Brakes

Check operation of brakes.

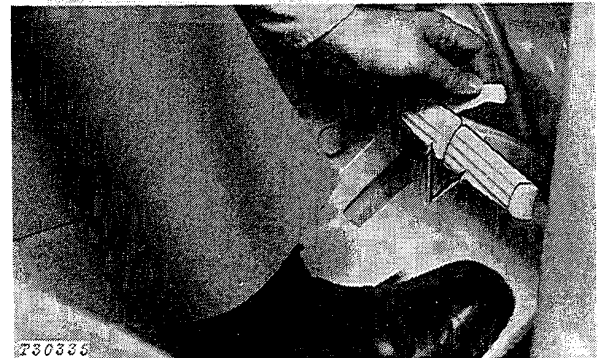

Fig. 20-Hydraulic Brakes

To stop the machine, push down both brake pedals. The machine must not pull to one side when stopping.

Turn to the left (L.H.). Push down the left (L.H.) brake pedal as you turn. Turn to the right (R.H.). Push down the right (R.H.) pedal as you turn.

The operator must feel the braking action pulling the machine to the left (L.H.) or right (R.H.). Brake action must be the same for both brakes.

Hydraulic brakes checked Yes No

18. Clutch Pedal Free Travel

Without Reverser (with continuous PTO)

Check the free travel of the clutch pedal. Free travel (1, Fig. 21) must be 1/2 in. (13 mm) to 1 in. (25 mm).

IMPORTANT: Do not operate the machine when the free travel of the clutch pedal is less than 1/2 inch (13 mm).

See page 10-10-22 for adjustment of free travel.

Without Reverser (with no PTO or with independent PTO)

Push the clutch pedal down until the clutch fingers contact the throwout bearing. Measure the distance from the pedal arm to where the pedal arm contacts the pedal stop. This distance must be 5 in. (127 mm).

If adjustment is needed, see page 10-10-22.

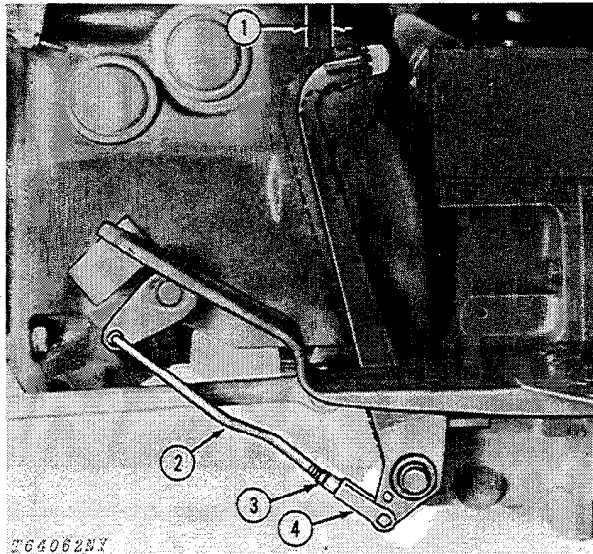

1—Specified Free Travel
 2—Clutch Rod
 3—Jam Nut
 4—Yoke

Fig. 21-Clutch Pedal Free Travel
 (Without Reverser)

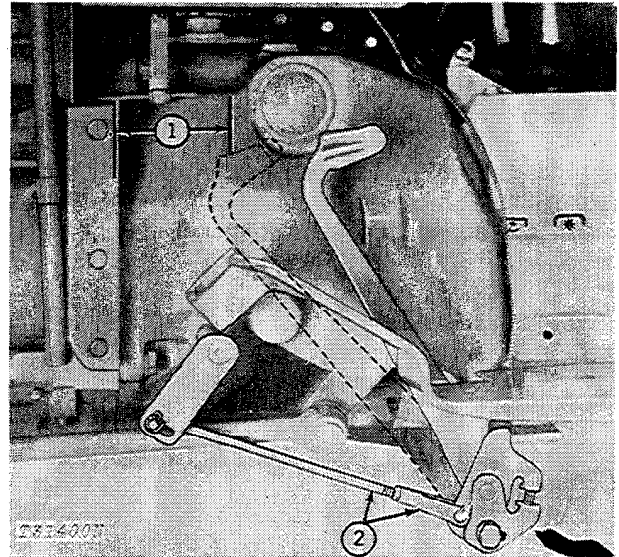

1—5-1/4 inches (133 mm) to 5-3/4 (146 mm)
 2—Pedal Adjusting Rod and Yoke

Fig. 22-Clutch Pedal Free Travel
 (With Reverser)

With Reverser

Check the free travel of the clutch pedal. Push the pedal down to the bottom of the first stage detent. In this position the throwout bearing will be against the clutch fingers. The top right (R.H.) edge of the rear of the pad of the clutch pedal must be 5-1/4 in. (133 mm) to 5-3/4 in. (146 mm) from the front of the bolting flange of the clutch housing. See 1, Fig. 22.

If free travel is more than 5-3/4 in. (146 mm), see page 10-10-22 for adjustment.

Free travel checked

Yes No

19. Engine Crankcase Vent Tube

Remove the vent tube. Clean it with diesel fuel. Install the vent tube. Be sure the packing fits correctly in the tappet cover.

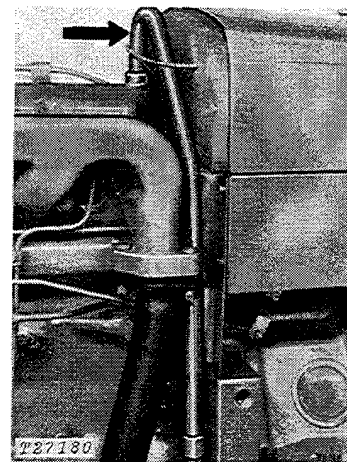

Fig. 23-Crankcase Vent Tube

Vent tube cleaned

Yes No

Thank you very much for your reading. Please Click Here. Then Get COMPLETE MANUAL. NO WAITING



NOTE:

If there is no response to click on the link above, please download the PDF document first and then click on it.

20. Seat

Check the operation of the seat.

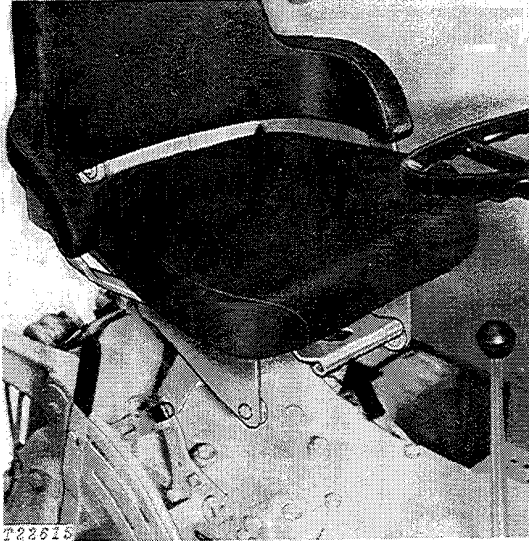
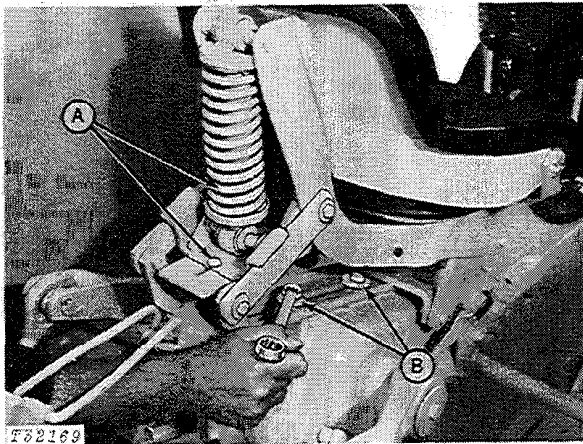

Fig. 24-Seat Release Latch (Deluxe Seat)

To move the seat to the upper rear position for standing, lift the release latch (Fig. 24). Stand. Lift the seat to the upper rear position.

To move the seat back to normal position, pull the seat forward. The seat will automatically go back to normal position when you sit.



A—Weight Adjustment

B—Height Adjustment

Fig. 25-Seat Adjustments

To change the adjustment for the height of the seat, loosen the cap screws (B, Fig. 25). Slide the seat to the desired position. Tighten the cap screws thoroughly.

To change the adjustment for the weight of the operator, move the seat to the upper rear position. Loosen the wing nuts under the support for the shock absorber. Slide the support to the desired position. Tighten the wing nuts.

Seat operation checked

Yes No

21. Power Steering

Check the operation of the power steering. The steering wheel must turn freely in both directions without seizure or too much play.

Power steering checked

Yes No

22. Power Take-Off

Check power take-off operation.

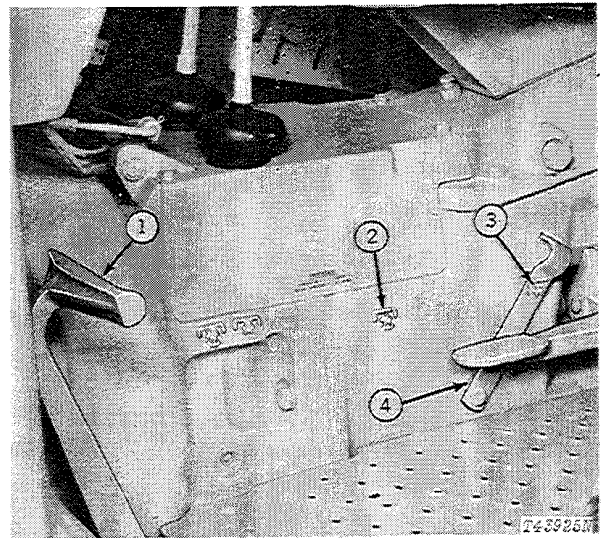

1—PTO Clutch
2—On

3—Off
4—PTO Lever

Fig. 26-PTO Operation

IMPORTANT: Disengage PTO clutch at pedal before shifting PTO selector lever. PTO lever must be in fully engaged or "ON" position to avoid excessive spline wear.

Continuous-Running PTO

To engage the PTO, completely depress the clutch pedal (momentarily wait for machine motion to stop). Move the PTO selector lever to the "ON" position. Slowly engage the clutch pedal.

To disengage the PTO, completely depress the clutch pedal. Shift the selector lever to the "OFF" position.

IMPORTANT: Always disconnect rear PTO stub shafts when not in use.

PTO operation checked Yes No

23. Loader Control Levers

Check the operation of the loader control levers.

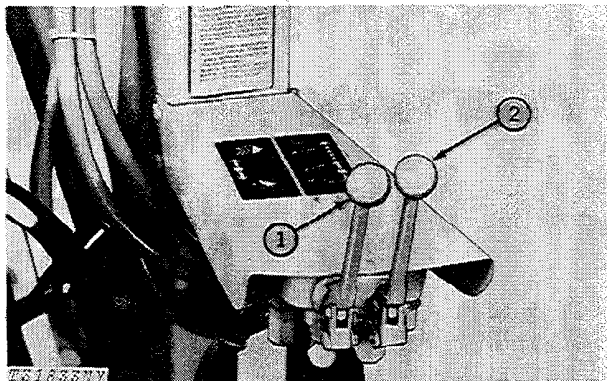

1—Bucket Control Lever 2—Boom Control Lever

Fig. 27-Loader Control Levers

CAUTION: Reduce boom lift speed when raising loaded bucket to full height.

Boom Lever

Push the lever forward to lower the boom. Pull the lever rearward to raise the boom.

If the lever is released during normal loader operation, it will return to neutral. The boom will be held in the position reached at that time.

Push the boom control lever all the way forward for float position. The lever will stay in this position until it is manually returned to neutral.

Bucket Lever

Push the lever forward to dump the bucket. Pull the lever rearward to retract the bucket.

If the lever is released, it will return to neutral. The bucket will be held in the position reached at that time.

Loader control levers checked Yes No

24. Hand Throttle

Check operation of hand throttle.

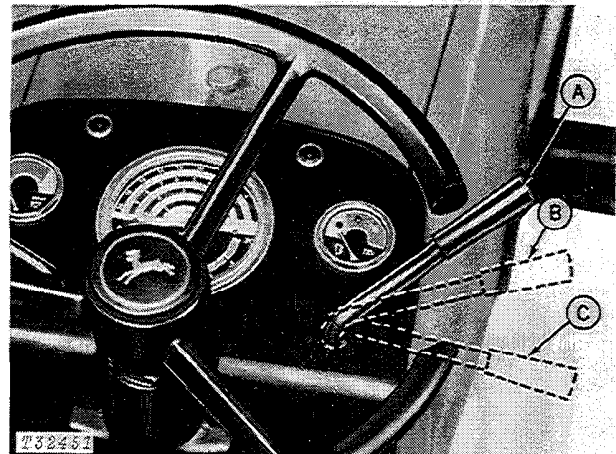

A—Slow Idle C—Fast Idle
 B—PTO Speed

Fig. 28-Hand Throttle

Hand throttle checked Yes No

25. Lights

Check the operation of the lights.

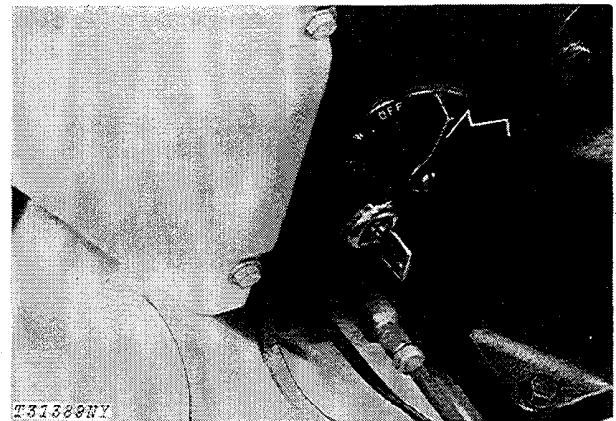

Fig. 29-Light Switch

Position	Headlights	Warning Lamps	Rear Combination Light
OFF	Off	Off	Off
W		On	
F	Dim		White
H	Bright	On	Red
H2	Dim	On	Red

NOTE: If customer desires, wire the lights to turn on when the key switch is off. Remove the purple wire from the "BAT" terminal. Install the unused red wire coming from the circuit breaker. Tape the end of the purple wire.

All lights checked Yes No

26. Parking Brake

Check the operation of the parking brake.

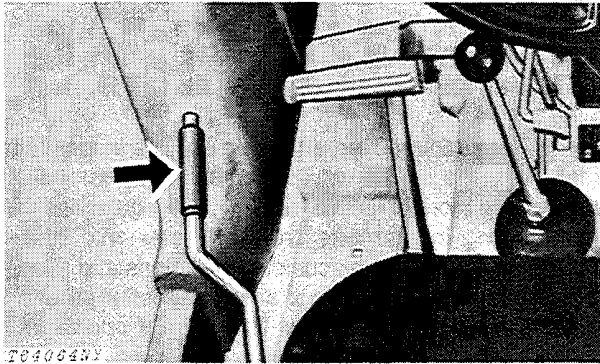

Fig. 30-Parking Brake

1. To engage, pull up.
 2. To disengage, press button and push lever down.
- If adjustment is needed, see page 10-10-25.

Parking brake checked Yes No

27. Toe-In.

Check the front wheel toe-in.

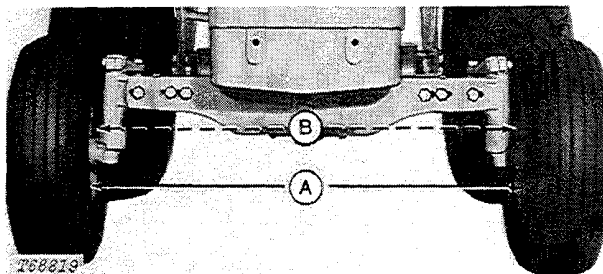

A—Distance Between Front of Rims

B—Distance Between Rear of Rims

Fig. 31-Checking Toe-In

1. Use down pressure of loader bucket to raise front wheels. Turn wheels so each valve stem is at bottom of tire.

2. Lower wheels to ground.
3. Measure from ground to hub.
4. Mark this distance on inside of each rim at the bead of tire front (A) and rear (B).
5. Measure distance between rims at front and rear marks.
6. Distance between front of rims must be 1/8 to 3/8 in. (3 to 9.5 mm) less than distance between rear of rims.

If adjustment is needed, see page 10-10-27.

Toe-in checked Yes No

28. Wheel Retainers

Check the torque of the wheel retainers.

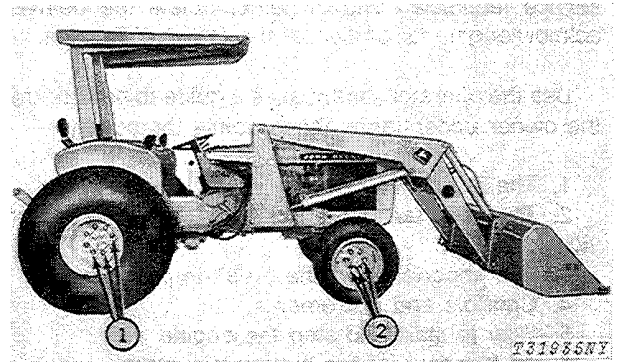

1—Rear Wheel Retainer

2—Front Wheel Retainer

Fig. 32-Wheel Retainers

Tighten front and rear wheel retainers to 100 lb-ft (14 kg-m).

Wheel retainers checked Yes No

29. Accessible Hardware Torque Values

Check all accessible bolts and nuts for correct tightness. If any bolts or nuts are loose, tighten them to the correct torque. See the torque chart on page 10-10-28.

Accessible hardware checked Yes No

30. Final Check

The final predelivery procedure is the overall clean-up of the unit. Make the unit LOOK like a new machine with the proper touch-up of chipped paint and a good wash job. Deliver to the customer a tractor anyone would be proud to own.