

**John Deere
JD646
Compactor**

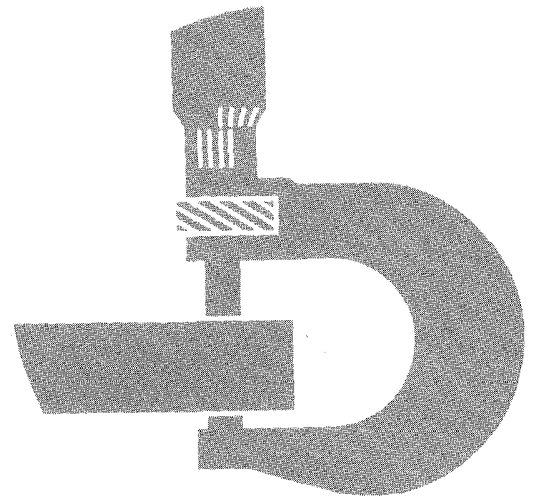

TECHNICAL MANUAL

TM-1073
Litho in U.S.A. (T) New

JD646 COMPACTOR**TECHNICAL MANUAL
TM-1073 (Mar-74)****CONTENTS****Section 10 - GENERAL**

- Group 5 Specifications
- Group 10 Predelivery, Delivery, and After-Sale Services
- Group 15 Tune-Up and Adjustment
- Group 20 Lubrication
- Group 25 Compactor Separation
- Group 30 Specifications and Special Tools

Section 20 - ENGINE

- Group 5 Diagnosis
- Group 10 Basic Engine
- Group 15 Engine Lubrication
- Group 20 Speed Control Linkage
- Group 25 Engine Cooling
- Group 30 Specifications and Special Tools

Section 30 - FUEL SYSTEM

- Group 5 System Diagnosis
- Group 10 Tank, Filters, and Transfer Pump
- Group 15 Air Intake System
- Group 20 Fuel Injection Pump
- Group 25 Robert Bosch Injection Nozzles
- Group 30 Specifications and Special Tools

Section 40 - ELECTRICAL SYSTEM

- Group 5 Wiring Diagrams
- Group 10 Charging Circuit
- Group 15 Starting Circuit
- Group 20 Gauges and Switches
- Group 25 Specifications and Special Tools

Section 50 - POWER TRAIN

- Group 5 System Diagnosis
- Group 10 Damper Assembly and Drive Shafts
- Group 15 Transmission Assembly
- Group 20 Axle Assemblies
- Group 25 Differentials
- Group 30 Specifications and Special Tools

Section 60 - POWER STEERING AND BRAKE SYSTEMS

- Group 5 General Information, Testing, and Diagnosis
- Group 10 Hydraulic Pump
- Group 15 Filters, Oil Cooler, and Accumulators
- Group 20 Steering System
- Group 25 Brake System
- Group 30 Specifications and Special Tools

Section 70 - HYDRAULIC SYSTEM (Loader Functions)

- Group 5 General Information, Testing, and Diagnosis
- Group 10 Reservoir and Filters
- Group 15 Hydraulic Pump
- Group 20 Control Valve
- Group 25 Return-to-Dig Valve
- Group 30 Cylinders
- Group 35 Specifications and Special Tools

Section 80 - MISCELLANEOUS

- Group 5 Frames
- Group 10 Buckets
- Group 15 Multi-Purpose Bucket
- Group 20 Demolition Wheels
- Group 25 Specifications and Special Tools

INDEX

The specifications and design information contained in this manual were correct at the time it was printed. It is John Deere's policy to continually improve and update our machines. Therefore, the specifications and design information are subject to change without notice. Wherever applicable, specifications and design information are in accordance with SAE and IEMC standards.

Copyright 1972
DEERE & COMPANY
Moline, Illinois
All rights reserved

INTRODUCTION

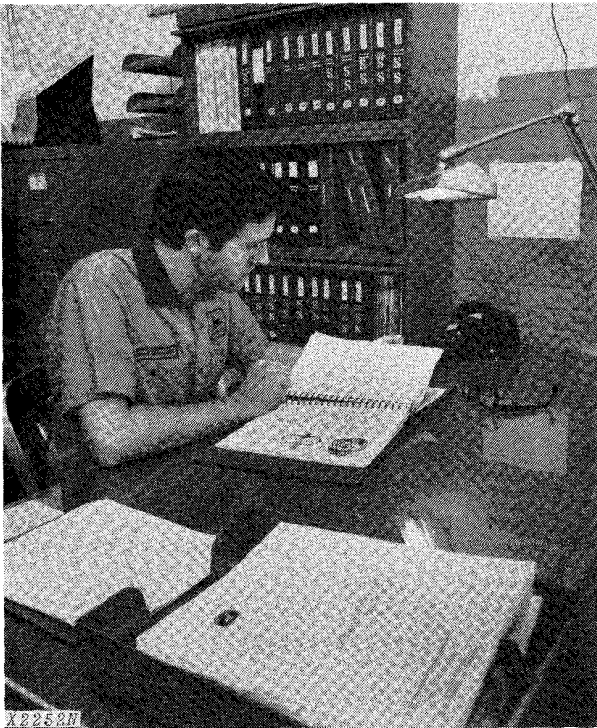

Use FOS Manuals for Reference

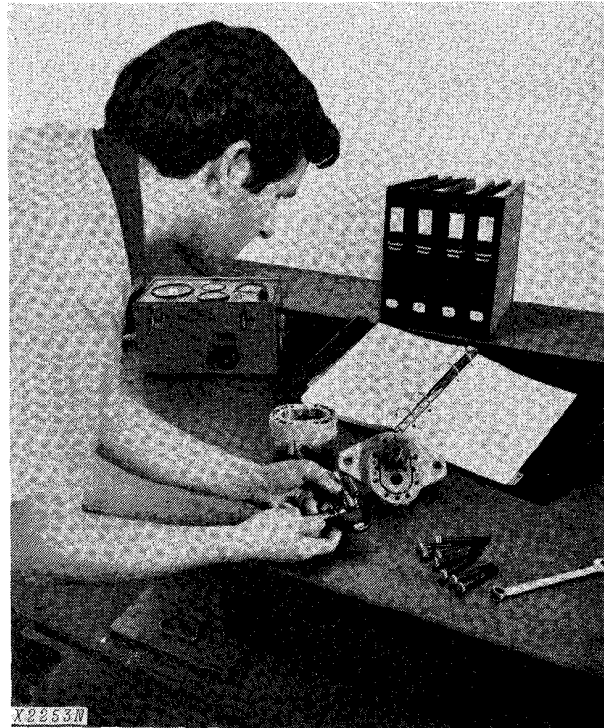

Use Technical Manuals for Actual Service

This technical manual is part of a twin concept of service:

- **FOS Manuals—for reference**
- **Technical Manuals—for actual service**

The two kinds of manuals work as a team to give you both the general background and technical details of shop service.

Fundamentals of Service (FOS) Manuals cover basic theory of operation, *fundamentals* of trouble shooting, *general* maintenance, and *basic* types of failures and their causes. FOS Manuals are for training new men and for reference by experienced men.

Technical Manuals are concise service guides for a *specific* machine. Technical Manuals are on-the-job guides containing only the vital information needed by a journeyman mechanic.



When a serviceman should refer to a FOS Manual for more information, a FOS symbol like the one at the left is used in the TM to identify the reference.

Some features of this technical manual:

- *Table of contents at front of manual*
- *Exploded views showing parts relationship*
- *Photos showing service techniques*
- *Specifications grouped for easy reference*

This technical manual was planned and written for you—a journeyman mechanic. Keep it in a permanent binder in the shop where it is handy. Refer to it whenever in doubt about correct service procedures or specifications.

Using the technical manual as a guide will reduce error and costly delay. It will also assure you the best in finished service work.



This safety alert symbol identifies important safety messages in this manual. When you see this symbol, be alert to the possibility of personal injury and carefully read the message that follows.

Section 10 GENERAL

CONTENTS OF THIS SECTION

	Page		Page
GROUP 5 - SPECIFICATIONS		GROUP 15 - TUNE-UP AND ADJUSTMENT	
Engine	5-2	Preliminary Engine Testing	15-1
Electrical System	5-2	Engine Tune-Up	15-1
Transmission	5-2	Compactor Adjustments	15-3
Travel Speeds	5-2		
Differentials	5-2	GROUP 20 - LUBRICATION	
Demolition Wheels	5-2	Lubrication Chart (capacities	
Compactor Hydraulic System	5-2	and lubricants)	20-1
Drive Axles	5-2	Engine Lubricating Oils	20-2
Power Steering and Brakes		Compactor Hydraulic Oil	20-2
Hydraulic System	5-2	Transmission Hydraulic Oil	20-2
Capacities	5-2	Greases	20-2
Compactor Operation Information	5-3		
Compactor Dimensions	5-3	GROUP 25 - COMPACTOR SEPARATION	
		Separating Loader and Engine Frames	25-1
GROUP 10 - PREDELIVERY, DELIVERY, AND		Removing Engine	25-2
AFTER-SALE SERVICES		Removing Transmission	25-3
Predelivery Service	10-1	Removing Axle Housing and	
Delivery Service	10-3	Differential Assemblies	25-4
After-Sale Service	10-3		
		GROUP 30 - SPECIFICATIONS AND	
		SPECIAL TOOLS	30-1

Group 5 SPECIFICATIONS

HORSEPOWER* (at 2,200 engine rpm):	SAE	PS
Gross	141	143
Net	131	133

* Net engine flywheel horsepower is for an engine equipped with fan, air cleaner, water pump, lubricating oil pump, fuel pump, alternator, and muffler. The gross engine horsepower is without fan. Gross and net flywheel horsepower ratings are under SAE standard conditions of 500-ft. altitude and 85°F. temperature and DIN 70 020 (non-corrected). Engine maintains rated horsepower up to 10,000 feet (3,000 m) altitude.

ENGINE:

John Deere Diesel, vertical 6-cylinder, valve-in-head, 4-stroke cycle—turbo-built with turbocharger.
 Bore and stroke 4.25x4.75 in. (108x121 mm)
 Piston displacement 404 cu. in. (6620 cm)
 Compression ratio 16.5 to 1
 Maximum torque @ 1,600 rpm 348 lb-ft. (48, 1 kg-m)
 N.A.C.C. or A.M.A. (U.S. Tax) horsepower 43.3
 Lubrication Pressure system with full-flow filter
 Cooling Pressurized with thermostat and fixed bypass
 Fan Suction-type
 Air cleaner ... Dry type, dual element with restriction indicator
 Lights and starting system 12-volt with alternator
 Batteries, two Reserve capacity: 180 minutes each

TRANSMISSION:

Twin-turbine torque converter with Power-Shift transmission (4 speeds forward—2 reverse).

TORQUE MULTIPLICATION RATIO 3.2 to 1

DIFFERENTIALS:

Front "No-Spin" type
 Rear Standard

DRIVE AXLES:

4-wheel drive with inboard-mounted planetary gears to each wheel. Front axle fixed. Rear axle oscillates 22-degree total. 15.3 in. (339 mm) vertical travel at center of tire.

RECOMMENDED TRAVEL SPEEDS:

Forward and reverse 4.5 mph maximum

BRAKES:

Service...Power actuated, 4-wheel, inboard-mounted wet disk. Foot-operated by either right or left pedal.
 Parking...10x1.5-in. (254x38 mm) expanding shoe type on transmission output shaft. Adjustable, hand operated with warning light on dash.

STEERING:

Full power steering. Frame articulated 80 degrees by two hydraulic cylinders. Vehicle clearance circle is 36 ft. 10.8 in. (11,25 m).

HYDRAULIC SYSTEMS:

Loader functions system...Live, transmission-driven, vane-type pump delivers 60 gpm (227 lpm) at 2,200 engine rpm and 2,250 psi (158,2 kg/cm²) relief-valve pressure setting.

ControlDual-lever, triple hydraulic system. bucket.

Steering and brake systems...Engine-driven, eight-piston, variable-displacement-type pump delivers 26 gpm (98 lpm) at 2,200 engine rpm and 2,250 psi (158.2 kg/cm²).

LANDFILL BUCKETS:

	Capacity	Width
Refuse Dirt:	2-3/4 cu. yd. (2,10 m ³)	110.77 in. (2,81 m)
..... Refuse:	4-1/2 cu. yd. (3,44 m ³)	
Light materials	4-1/2 cu. yd. (3,44 m ³)	110.77 in. (2,81 m)
Multi-purpose Dirt:	2/1/4 cu. yd. (1,72 m ³)	106.4 in. (2,70 m)
..... Refuse:	3-1/2 cu. yd. (2,68 m ³)	

COMPACTOR WHEELS:

Width 23 in. (584 mm)
 Diameter 55 in. (1397 mm)
 60° cleats, 32/wheel 5 in. (127 mm)
 Encased General tires 13-24, 12 pr
 Compaction Up to 2,898 psi

WHEEL TREADS AND WIDTH:

Front and rear (center-to-center) 81.5 in. (2,07 m)
 Width outside wheels 104.5 in. (2,65 m)

CAPACITIES:

	U.S.	Liters
Cooling system	9 gal.	34,1
Fuel tank	50 gal.	189,3
Crankcase and filter	17 qt.	16,1
Transmission case and filters	9.75 gal.	36,9
Front differential	6 gal.	22,7
Rear differential	6.5 gal.	24,6
Loader hydraulic sump	17.5 gal.	66,2

OPERATING WEIGHT:

	lb.	kg
With refuse bucket	30,012	13625
With multi-purpose bucket	30,282	13747

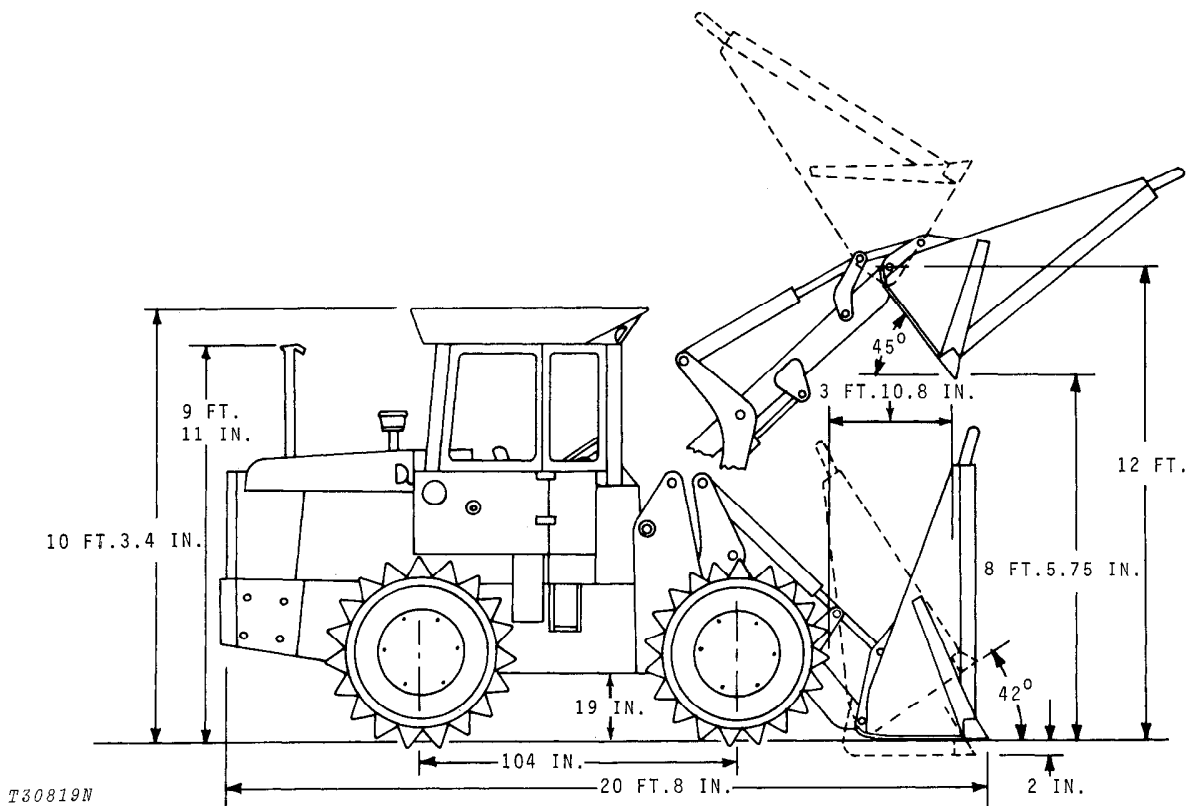

ADDITIONAL STANDARD EQUIPMENT:

- Adjustable cushioned seat
- Engine side shields
- Key switch
- Cigaret lighter
- Vandal protection
- Horn
- Automatic return-to-dig
- Fixed drawbar
- Vertical exhaust w/rain cap
- Hand grips
- Electric hour meter
- Ether starting aid
- Heater for cab
- Defroster
- Fire extinguisher
- Radiator screen
- Push button safety start
- ROPS cab and seat belt

SPECIAL EQUIPMENT:

- Pre-cleaner
- Multi-purpose refuse bucket:
 - 2-1/4 yd. dirt capacity, 3-1/2 yd. refuse capacity
- Light-materials bucket:
 - 4-1/2 yd. capacity

(Specifications and design are subject to change without notice. Wherever applicable, specifications are in accordance with IEMC and SAE Standards. Except where otherwise noted, these specifications are based on a unit equipped with demolition wheels; refuse bucket, and standard equipment.)

**Thank you very much
for your reading. Please
Click Here Then Get
More Information.**

NOTE:

**If there is no response to
click on the link above,
please download the PDF
document first and then
click on it.**

Group 10

PREDELIVERY, DELIVERY AND AFTER-SALE SERVICES

PREDELIVERY SERVICE

Because of the shipping factors involved, plus extra finishing touches that are necessary to promote customer satisfaction, proper delivery service is of prime importance to the dealer.

A tag pointing out the factory-recommended procedure for predelivery service is attached to each new compactor before it leaves the factory.

After completing the factory-recommended dealer checks and services listed on the predelivery tag, remove the tag from the compactor and file it with the shop order for the job. The tag will then serve as a basis for certifying that the compactor has received the proper predelivery service when that portion of the customer's John Deere Delivery Receipt is completed.

TEMPORARY COMPACTOR STORAGE

Service	Specification	Reference
Check radiator for coolant loss and antifreeze protection	Bottom of filler neck
Reduce shipping pressure of tires	Operator's Manual
Cover compactor for protection and cleanliness

PREDELIVERY INSPECTION

COOLING SYSTEM

Inspect radiator for coolant loss	Bottom of filler neck
Check antifreeze protection

ELECTRICAL SYSTEM

Check battery terminals to be sure they are tight
Remove brake fuse from spare fuse holder and insert into fuse block. Test lights	Section 40, Group 10

TIRES AND WHEELS

Adjust tire pressure	70 psi	Operator's manual
Check all wheel retainers for tightness	275 ft-lbs torque	Operator's manual

PREDELIVERY INSPECTION—Continued

Service	Specification	Reference
LUBRICATION		
Check crankcase oil level	To top mark on dipstick	Operator's manual
Compactor hydraulic system oil level	Check oil level at window (JD303 Special-Purpose Oil)	Operator's manual
Check oil level in front and rear differentials	To level of check plug (cold) (JD303 Special-Purpose Oil)	Operator's manual
Check transmission oil level	To top mark on dipstick (J.D. Torque-Converter Fluid Type C-2)	Operator's manual
Lubricate grease fittings	John Deere Multi-Purpose Lubricant or an equivalent	Operator's manual
ENGINE		
Check air cleaner	Operator's manual
Fill fuel tank and start engine	50 U.S. gallons	Operator's manual
Check operation of lights, gauges and indicator lights	Operator's manual
Check speed control linkage	Section 20, Group 20
Check engine speeds	Section 20, Group 20
OPERATION		
Shift transmission through all ranges	Operator's manual
Check hydraulic system operation	Section 70, Group 5
Check clutch cutoff control disconnect	Section 60, Group 5
Check rear axle disconnect operation	Section 50, Group 15
Check fire extinguisher	Operator's manual
Check brake operation	Section 60, Group 5
Check steering operation	Section 60, Group 5
Check seat operation	Operator's manual
GENERAL		
Tighten accessible nuts and cap screws
Clean compactor and touch up paint

DELIVERY SERVICE

A thorough discussion of the operation and service of a new compactor at the time of delivery helps to assure customer satisfaction. Proper delivery should be an important phase of a dealer's program. A portion of the John Deere Delivery Receipt emphasizes the importance of proper delivery service.

It is a well-known fact that many complaints have arisen simply because the owner was not shown how to operate and service his new unit properly. Devote enough time, at the customer's convenience, to introduce the owner to his new compactor and explain to him how to operate and service it.

The following procedure is recommended before the service man and the owner complete the delivery acknowledgments portion of the delivery receipt.

Using the compactor operator's manual as a guide, be sure that the owner understands these points thoroughly:

1. The importance of safety.
2. The importance of lubrication and periodic services.
3. Controls and Instruments.
4. How to start and stop the engine.
5. The importance of the break-in period.
6. All functions of the hydraulic system.

After explaining and demonstrating the above features, have the owner sign the delivery receipt and give him the operator's manual.

AFTER-SALE SERVICE

The purchaser of a new John Deere compactor is entitled to a free inspection at some mutually agreeable time within the warranty period after the equipment has been "run in." The terms of this after-sale inspection are outlined on the back of the customer's John Deere delivery receipt.

The purpose of this inspection is to make sure that the customer is receiving satisfactory performance from his compactor. At the same time, the inspection should reveal whether or not the compactor is being operated, lubricated, and serviced properly.

If the recommended after-sale service inspection is followed, the dealer can eliminate a needless volume of service work by preventing minor irregularities from developing into serious problems later on. This will promote strong dealer - customer relations and present the dealer an opportunity to answer questions that may have arisen during the first few days of operation. During the inspection service, the dealer has the further opportunity of promoting the possible sale of other new equipment.

AFTER-SALE INSPECTION

Service	Specification	Reference
COOLING SYSTEM		
Check radiator coolant level	Bottom of filler neck
Check hoses and connections for leaks
FUEL SYSTEM		
Bleed fuel system	Operator's manual

AFTER-SALE INSPECTION—Continued

Service	Specification	Reference
Check fuel line connections
Check air cleaner element and unloading valve. Clean element if necessary	Operator's manual
ELECTRICAL SYSTEM		
Check specific gravity of batteries	Full charge - 1.260 at 80°F	Operator's manual
Check level of battery electrolyte	To bottom of filler neck in each cell	Operator's manual
Check alternator belt tension	75 to 85 lbs. tension (measured on a test gauge). After 3 minutes of operation, tension should be 60 lbs. minimum	Operator's manual
Check fan belt tension	110 to 110 lbs. tension (measured on a test gauge). After 3 minutes of operation, tension should be 80 lbs. minimum	Operator's manual
Start engine and check action of starter, lights, and indicator lamps	Operator's manual
LUBRICATION		
Check engine crankcase oil level	To top mark on dipstick	Operator's manual
Check transmission oil level	To top mark on dipstick (J.D. Torque Converter Fluid Type C-2)	Operator's manual
Check hydraulic system oil level	Check oil level at window (JD303 Special-Purpose Oil)	Operator's manual
Check oil levels in front and rear differentials	To level of check plug (Cold oil) (JD303 Special-Purpose Oil)	Operator's manual

AFTER-SALE INSPECTION—Continued

Service	Specification	Reference
ENGINE		
Check engine valve tappet clearance	Intake - 0.018-inch Exhaust - 0.022-inch	Section 20, Group 10
CONTROLS		
Check clutch cutoff	Section 50, Group 15
Check return-to-dig valve operation	Check oil level and adjust (JD303 Special-Purpose Oil)	Operator's manual
HYDRAULIC SYSTEM		
Check power steering	Section 60, Group 5
Check power brakes	Less than 2 inches of travel	Operator's manual
Check brake accumulator	20 brake pedal applications with engine stopped	Section 60, Group 5
GENERAL		
Check fire extinguisher	Operator's manual
Check tire pressure	70 psi	Operator's manual
Check wheel retainers for tightness	275 ft-lbs torque	Operator's manual
Clean out radiator screen	Operator's manual