

# JOHN DEERE 400 AND 425 HAY CUBERS



JOHN DEERE

## TECHNICAL MANUAL JOHN DEERE 400 AND 425 HAY CUBERS

TM1010 (01JUL74) English

TM1010 (01JUL74)

LITHO IN THE U.S.A.  
ENGLISH

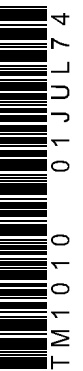

# 400 AND 425 HAY CUBERS

## Technical Manual

### TM-1010 (Jul-74)

#### CONTENTS

##### Section 10 - GENERAL

- Group 5 - Specifications
- Group 10 - Function Times
- Group 15 - Lubrication
- Group 20 - Separation

##### Section 20 - ENGINE

- Group 5 - Basic Engine

##### Section 30 - ELECTRICAL SYSTEM

- Group 5 - Description and Wiring Diagrams

##### Section 40 - POWER TRAIN

- Group 5 - Power Take-Off and Main Drive
- Group 10 - Variable Speed Sheave
- Group 15 - Input Drive and Wheel Drive Clutch
- Group 20 - Transmission and Differential
- Group 25 - Final Drives
- Group 30 - Specifications

##### Section 50 - STEERING AND BRAKES

- Group 5 - Steering
- Group 10 - Brakes
- Group 15 - Specifications

##### Section 60 - HYDRAULIC SYSTEM

- Group 5 - Components and Tests
- Group 10 - Filter with Bypass Valve
- Group 15 - Main Hydraulic Pump
- Group 20 - Function Control Valves
- Group 25 - Hydraulic Cylinders
- Group 30 - Hydraulic Steering
- Group 35 - Breakaway Coupler
- Group 40 - Specifications

##### Section 70 - MACHINE FUNCTIONS

- Group 5 - Water System
- Group 10 - Pickup and Cutterhead
- Group 15 - Cubing Mechanism
- Group 20 - Specifications

*All information, illustrations and specifications contained in this technical manual are based on the latest information available at the time of publication. The right is reserved to make changes at any time without notice.*

## INTRODUCTION



*Use FOS Manuals for Reference*

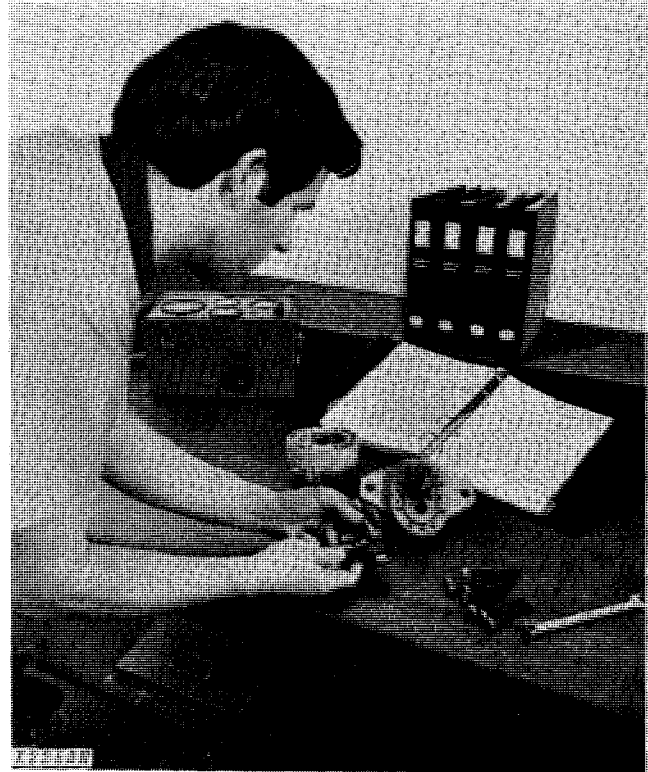

*Use Technical Manuals for Actual Service*

This technical manual is part of a twin concept of service:

- **FOS Manuals—for reference**
- **Technical Manuals—for actual service**

The two kinds of manuals work as a team to give you both the general background and technical details of shop service.

*Fundamentals of Service (FOS) Manuals* cover basic theory of operation, *fundamentals* of trouble shooting, *general* maintenance, and *basic* types of failures and their causes. FOS Manuals are for training new men and for reference by experienced men.

*Technical Manuals* are concise service guides for a specific machine. Technical Manuals are on-the-job guides containing only the vital information needed by a journeyman mechanic.



When a serviceman should refer to a FOS Manual for more information, a FOS symbol like the one at the left is used in the TM to identify the reference.

Some features of this technical manual:

- *Table of contents at front of manual*
- *Exploded views showing parts relationship*
- *Photos showing service techniques*
- *Specifications grouped for easy reference*

This technical manual was planned and written for you—a journeyman mechanic. Keep it in a permanent binder in the shop where it is handy. Refer to it whenever in doubt about correct service procedures or specifications.

Using the technical manual as a guide will reduce error and costly delay. It will also assure you the best in finished service work.



This safety alert symbol identifies important safety messages in this manual. When you see this symbol, be alert to the possibility of personal injury and carefully read the message that follows.

# Section 10 GENERAL

## CONTENTS OF THIS SECTION

	Page		Page
GROUP 5 SPECIFICATIONS		GROUP 15 LUBRICATION	
Machine Specifications .....	5-1	Lubrication Chart .....	15-1
Standard Torque Chart .....	5-2		
GROUP 10 FUNCTION TIMES		GROUP 20 SEPARATION	
Hydraulic System Average Function		Drive Train .....	20-1
Times .....	10-1	Pickup and Cutterhead .....	20-2

## Group 5 SPECIFICATIONS

Over-all length:

Pickup gauge wheel to hitch:

400 Cuber.....20 ft. 6 in. (6.2 m)

425 Cuber.....20 ft. (6.1 m)

With elevator lowered .....31 ft. 1 in. (9.2 m)

Width .....8 ft. (2.4 m)

Height:

With elevator lowered:

400 Cuber.....12 ft. (3.7 m)

425 Cuber.....13 ft. 1 in. (4.0 m)

Without elevator and mufflers 8 ft. 10 in. (2.7 m)

Weight:

Empty:

400 Cuber.....(Approx.) 13200 lbs. (5987 kg)

425 Cuber.....(Approx.) 13880 lbs. (6296 kg)

With fuel and water tanks full:

400 Cuber.....(Approx.) 16205 lbs. (7350 kg)

425 Cuber.....(Approx.) 16885 lbs. (7659 kg)

Propelling drive..... Variable with V-belt

Ground speeds:

Variable range 1st ..... 1.7- 3.3 mph (1-3 km/h)

Variable range 2nd..... 3.3- 6.7 mph (2-5 km/h)

Variable range 3rd ... 6.7- 13.4 mph (5-11 km/h)

Variable range 4th . 13.4- 26.8 mph (10-22 km/h)

Variable range reverse 1.7- 3.8 mph (3-6 km/h)

Tire sizes:

Rear—low-profile all-weather

(28 psi [193 kPa]) ..... 14:9-26, 8-ply rated

Front-rib implement:

400 Cuber (40 psi [275 kPa]) ..... 7:50-16,  
6-ply rated

425 Cuber (35 psi [241 kPa]) ..... 11L-15,  
8-ply rated

Front gauge wheels—smooth

Implement (12 psi [83 kPa]) ..... 4:00-8,  
4-ply rated

Wheel tread—center to center:

Rear ..... 80-1/8 in. (204 cm)

Front:

400 Cuber..... 68-3/8 in. (174 cm)

425 Cuber..... 74-1/4 in. (189 cm)

Front gauge wheels:

400 Cuber..... 90 in. (229 cm)

425 Cuber..... 87 in. (221 cm)

Steering ..... Full-power hydrostatic

Brakes:

Mechanical:

400 Cuber ... Individual, mechanical disk type

425 Cuber (Serial No. -655)  
Individual, mechanical disk type

Hydraulic:

425 Cuber (Serial No. 656- )  
Individual 6 in. (15.24 cm)  
hydraulic disk type

Capacities: (All U.S. Measure)

Fuel tank ..... 83 gal. (314 l)

Water tank ..... 300 gal. (1135 l)

Engine cooling system..... 11 gal. (42 l)

Engine crankcase with filter ..... 5 gal. (19 l)

Transmission..... 14 pts. (7 l)

Final drives, each ..... 4-1/2 pts. (2 l)

Planetary gear box ..... 17 gal. (64 l)

Hydraulic reservoir ..... 8 gal. (30 l)

Hydraulic system (complete) ..... 10 gal. (38 l)

Main clutch ..... 11 in. O.C., double plate  
(27.94 cm)

Pickup width between flares .. 6 ft. 1 in. (1.9 m)

Pickup draper belt speed

(400 Cuber) ... 313 rpm or 3.6 mph (6 km/h)

Pickup cylinder speed (425 Cuber) .. 65-137 rpm

Pickup feeder speed (425 Cuber) .... 27-56 rpm

Pickup auger diameter..... 18 in. (45.72 cm)  
 Feed opening width ..... 20 in. (50.80 cm)  
 Number of cutterhead knives..... 2  
 Cutterhead speed ..... 1,373 rpm  
 Number of die openings ..... 66  
 Size of die opening ..... 1-1/4 in. sq.  
 (3.18 cm)  
 Length of die ..... 6 in. (15.24 cm)  
 Die..... Individually replaceable, heat-treated  
 alloy steel and chrome plated  
 Die-feeding means ..... Single press wheel  
 Unit density of cubes  
 45-55 lbs. per cu. ft. (721-881 kg/m<sup>3</sup>)  
 Bulk density of cubes  
 25-32 lbs. per cu. ft. (400-513 kg/m<sup>3</sup>)  
 Length of cube ..... 2 to 3 in. (5.08-7.62 cm)  
 Conveyor and elevator chain..... CA 2050 with  
 rubber flights  
 Water pump:  
 Type ..... Centrifugal  
 Capacity @ 2,800 rpm  
 and 25 psi (172 kPa) ..... 68 gal. per min.  
 (429 m<sup>3</sup>/s)  
 Water tank protection..... Coated inside with  
 corrosion-resistant material

**ENGINE**

Make of engine ..... Detroit Diesel 6V-71  
 Model No. .... Model 7064-7200  
 Engine type..... 2 cycle  
 Bore and stroke..... 4-1/4 x 5 in. (10.79 x  
 12.70 cm)  
 Net rated horsepower:  
 @85°F. and 500 ft. elev. .... 216 hp  
 Number of cylinders ..... 6  
 Piston displacement ..... 425.6 cu. in.  
 (1238 kg/m<sup>3</sup>)  
 Speed: No load ..... 2250 rpm  
 Full load ..... 2100 rpm  
 Idle Speed..... 750-800 rpm  
 Air cleaner..... Dry type  
 Electrical system ..... 12-volt generator  
 Type of fuel ..... Diesel  
 Compression ratio ..... 18:7:1  
 Battery size ..... 12-volt SAE Group 8D, 205 amp

(Specifications and design subject to change without notice.)

**STANDARD TORQUE CHART**

Use the following torque chart for tightening all bolts unless specified otherwise.

The types of bolts and cap screws are identified by head markings as follows:

Plain head: regular type.

3-dash head: tempered steel high-strength type.

6-dash head: tempered steel extra high-strength type.

Machine bolts and cap screws 7/8 inch and larger are sometimes formed hot rather than cold, which accounts for the lower torque value.

RECOMMENDED TORQUE IN FT-LBS (Nm) COARSE AND FINE THREADS			
Bolt Diameter	Plain Head	Three Dashes	Six Dashes
1/4	Not used	10 (14)	14 (19)
5/16	Not used	20 (27)	30 (41)
3/8	Not used	35 (47)	50 (68)
7/16	35 (47)	55 (75)	80 (108)
1/2	55 (75)	85 (115)	120 (163)
9/16	75 (102)	130 (176)	175 (237)
5/8	105 (142)	170 (230)	240 (325)
3/4	185 (251)	300 (407)	425 (576)
7/8	160 (217)	445 (603)	685 (929)
1	250 (339)	670 (908)	1030 (1397)
1-1/8	330 (447)	910 (1224)	1460 (1980)
1-1/4	480 (651)	1250 (1695)	2060 (2793)

E11162N

## Group 10 FUNCTION TIMES

### HYDRAULIC SYSTEM AVERAGE FUNCTION TIMES WITH OIL TEMPERATURE BETWEEN 120 AND 140 DEGREES FAHRENHEIT (48.9 AND 60.0 DEGREES CENTIGRADE) AND ENGINE SPEED AT 2100 RPM

Function	Time
Raise platform .....	1.5 ± .5 Seconds
Raise elevator .....	1.7 ± .5 Seconds
Steering:	
Left lock to right lock .....	3.5 ± .5 Seconds
Right lock to left lock .....	3.5 ± .5 Seconds
Variable speed sheave:	
Full fast to full slow .....	2.5 ± .5 Seconds
Full slow to full fast .....	2.5 ± .5 Seconds
Wagon bin dump .....	Less than 2 minutes

## Group 15 LUBRICATION

### GENERAL INFORMATION

Carefully written and illustrated lubrication instructions are included in the operator's manual furnished with your customer's machine. Remind him to follow these instructions.

For your convenience, the following chart shows capacities and types of lubricants for the cuber components and systems.

Component	Capacity	Type of Lubricant	Interval of Service
Engine crankcase and filter component	5 U.S. gallons (19 l)	See page 10-15-3	10 Hours - Check oil level 100 Hours - Drain and refill Change filter
Transmission	14 U.S. pints (7 l)	John Deere SAE 90 SCL-type Gear Lubricant or an equivalent SCL multi-purpose-type gear oil	500 Hours - Drain and refill
Transmission input shaft	1 U.S. pint (0.5 l)	John Deere SAE 90 SCL-type Gear Lubricant or an equivalent SCL multi-purpose-type gear oil	500 Hours - Drain and refill
Final drives	4-1/2 U.S. pints (2 l)	SAE 90-140 API-GL5 Gear Lubricant	500 Hours - Drain and refill
Main planetary gear box	17 U.S. gallons (64 l)	SAE 90-140 API-GL5 Gear Lubricant	100 Hours - Check oil level
Hydraulic system oil reservoir	8 U.S. gallons (30 l)	John Deere Type 303 Special Purpose Oil or its equivalent	10 Hours - Check oil level 1000 Hours - Change filter element and check oil level
Power take-off bearings and cutterhead idler pulley	Several shots	Shell Darina AX Grease or its equivalent	50 Hours
Press wheel crank bearing and press wheel bearing	Several shots	Shell Darina AX Grease or its equivalent	100 Hours
Driven pulley bearing	See page 10-15-2	Shell Darina AX Grease or its equivalent	100 Hours

Component	Capacity	Type of Lubricant	Interval of Lubricant
Pickup roll bearings (400 Cuber), pickup drives (425 Cuber), water pump drive, front axle spindles, and variable speed sheave	Several shots	John Deere Multi-Purpose Lubricant or an equivalent SAE multipurpose-type grease	10 Hours
Cutterhead, shaft bearings, idler arm, variable speed pivot, chain idlers, pickup gauge wheels, hydraulic pump pivot, and elevator lift pivots	Several shots	John Deere Multi-Purpose Lubricant or an equivalent SAE multipurpose-type grease.	50 Hours
Clutch and brake pedals, tachometer drive, main clutch, brake shaft, final drive couplers, brake idler, and shift bell cranks	Several shots	John Deere Multi-Purpose Lubricant or an equivalent SAE multipurpose-type grease	100 Hours
Conveyor bell crank, cross shaft, throw-out bearing	Several shots	John Deere Multi-Purpose Lubricant or an equivalent SAE multipurpose-type grease	300 Hours
Clevises, linkages, and chains	Several drops	SAE 30W engine oil	As required

### DRIVEN PULLEY BEARING

Every 100 hours of operation, remove clutch; then remove bolt nearest the bottom. Insert special fitting (supplied with machine). Remove bolt 180° opposite this fitting; then lubricate special fitting with Shell Darina AX Grease (or equivalent) until grease comes out top hole. Remove special fitting and replace both bolts. See Figure 1.

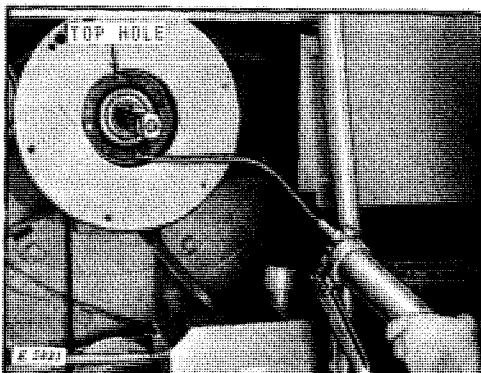

Fig. 1-Lubricating Driven Pulley Bearing



## ENGINE LUBRICATING OILS

Detroit Diesel engines have given optimum performance, and experienced the longest service life with MIL-L-2104B, SAE 30 Oils, with the following limitations:

1. Zinc, as zinc diorganodithiophosphate, between a minimum of 0.07 and a maximum of 0.10 percent by weight.
2. Sulfated ash (ASTM D-874) of 1.00 percent maximum by weight, except lubricants that contain only barium detergent - dispersants where 1.50 percent by weight is allowed.

Contact a reliable oil supplier and obtain his assurance that his product has been tested and given good performance in Detroit Diesel engines. An SAE 30 oil is recommended for year-round use. The use of lower viscosity oils or multigrade products will usually result in less than normal engine life.

The use of Low Ash Series 3 oils (sulphated ash less than 1.65 percent by weight - ASTM designation D-874) may be necessary if the continued use of high sulfur fuel (sulfur greater than 0.5 percent by weight - ASTM D-129) is unavoidable. Consult a reliable oil supplier, obtain assurance that his products have been tested in Detroit Diesel engines, and select the best performer for optimum engine life.

Low ash Series 3 oils do NOT have to meet any specific military low temperature performance requirements; therefore, they may NOT perform as well as MIL-L-2104B lubricants in cold climates.

Multigrade oils are NOT recommended. The use of an SAE-30 grade is desirable for year-round use when cold starting can be accomplished. Multigrade oils should be considered only as the "last resort" to facilitate starting when prolonged exposure to temperatures below freezing is unavoidable and adequate starting aids are unavailable.

Experience clearly indicates that multigrade oils are NOT comparable to SAE-30 lubricants for heavy duty diesel service. Cylinder liner scuffing, liner port and ring groove deposit levels are all greater using multigrade lubricants. This results in shortened engine life.

## HYDRAULIC OIL

Use only John Deere Type 303 Special-Purpose Oil or its equivalent in the cuber hydraulic system. Other types of oil will not give satisfactory service, and their use may result in eventual damage. This special oil may be used in all weather conditions.

## HYDRAULIC BRAKES (425 Cuber, Serial No. 656- )

Use SAE J1703d or Dot-3 hydraulic brake fluid in the brake reservoir.

## TRANSMISSION

Use only John Deere SAE 90 Gear Lubricant or an equivalent SCL multipurpose-type gear oil in the transmission.

## FINAL DRIVES

Use SAE 90-140 API-GL5 Gear Lubricant in the final drives.

## GREASES

Use John Deere Multi-Purpose Lubricant or an equivalent SAE multipurpose-type grease for all grease fittings on your cubing machine except where other is specified; the special heavy-duty, high-temperature grease (Shell Darina AX) specified for the press wheel and other locations is highly recommended.

## STORING LUBRICANTS

This cuber can operate efficiently only if clean lubricants are used. Use clean containers to handle all lubricants. Store them in an area protected from dust, moisture, and other contamination.

## Group 20 SEPARATION

### DRIVE TRAIN SEPARATION

#### **Separating Input Drive, Clutch, Brakes, and Transmission-Differential From Cuber**

The above parts are separated from the cuber as one complete unit.

This separation is made only when the transmission and differential unit is to be serviced.

The wagon hitch must be removed to make this separation.

#### **Separating Input Drive Housing From Clutch Housing**

This separation allows the servicing of the clutch assembly and is necessary to service the transmission and differential unit.

#### **Separating Clutch Housing From Transmission and Differential Case**

This separation allows the servicing of the transmission and differential unit.

#### **Separation of Brakes From Transmission and Differential Case**

This separation allows the servicing of the brakes and is necessary to service the transmission and differential case.

## PICKUP AND CUTTERHEAD SEPARATION FOR 400 CUBER

The pickup and cutterhead are separated from the cuber as an assembly. This separation allows complete servicing of both the pickup and cutterhead.

Follow in order the instructions below and refer to Figure 1 to separate the pickup and cutterhead assembly from the cuber.

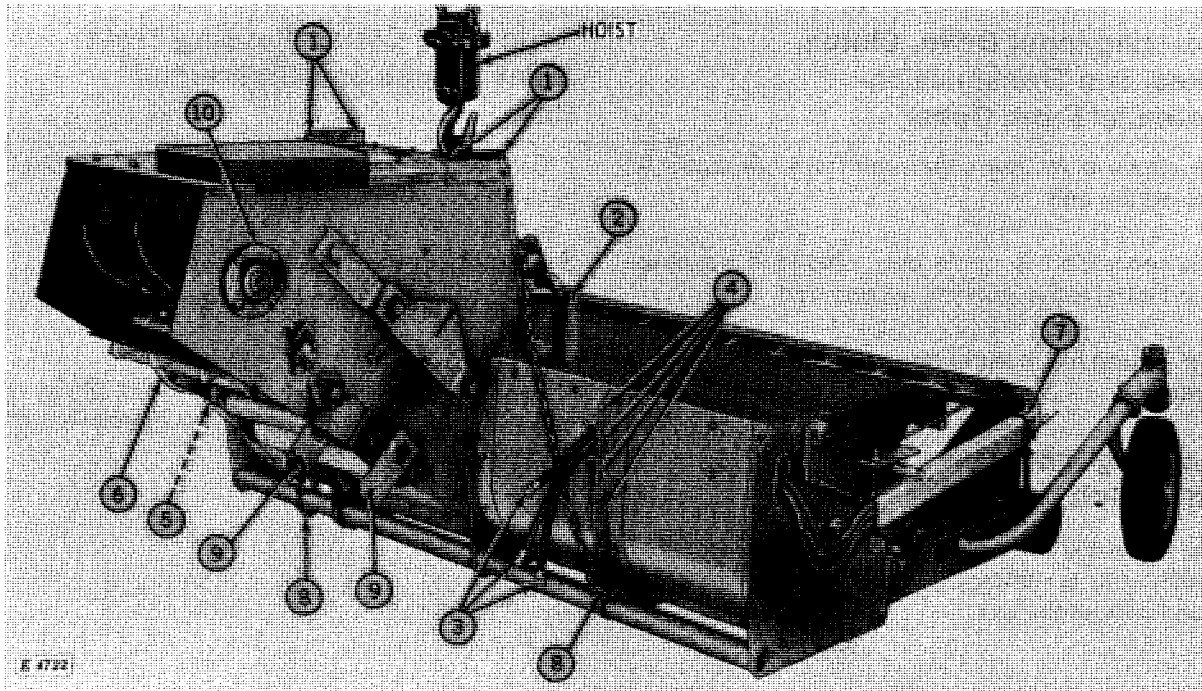

Fig. 1-Pickup and Cutterhead Separation

1. Remove platform front mounting bolts.
2. Disconnect lift cylinder at rod end.
3. Disconnect water hoses - code hoses for proper installation.
4. Remove the four bolts through auger housing angle and right-hand frame extension.
5. Remove shield over pickup drive; then, remove pickup drive chain.
6. Remove cutterhead drive belt from cutterhead sheave.
7. Wire each side of the boom to the pickup.
8. Place a lifting chain to the rear of the auger housing and anchor each end to the main cross pipe with one strand on each side of the feeder. Put a slight tension on the chain with a hoist.
9. Remove two bolts from feeder support to front axle assembly.
10. Remove the two bolts and clamp from each socket half at each cutterhead bearing (right and left-hand side).

**Thank you very much for  
your reading. Please Click  
Here. Then Get COMPLETE  
MANUAL. NO WAITING**



**NOTE:**

**If there is no response to  
click on the link above,  
please download the PDF  
document first and then  
click on it.**

## PICKUP AND CUTTERHEAD SEPARATION FOR 425 CUBER

The pickup and cutterhead are separated from the cuber as an assembly. This separation allows complete servicing of both the pickup and cutterhead.

Follow in order the instructions below and refer to Figure 2 to separate the pickup and cutterhead assembly from the cuber.

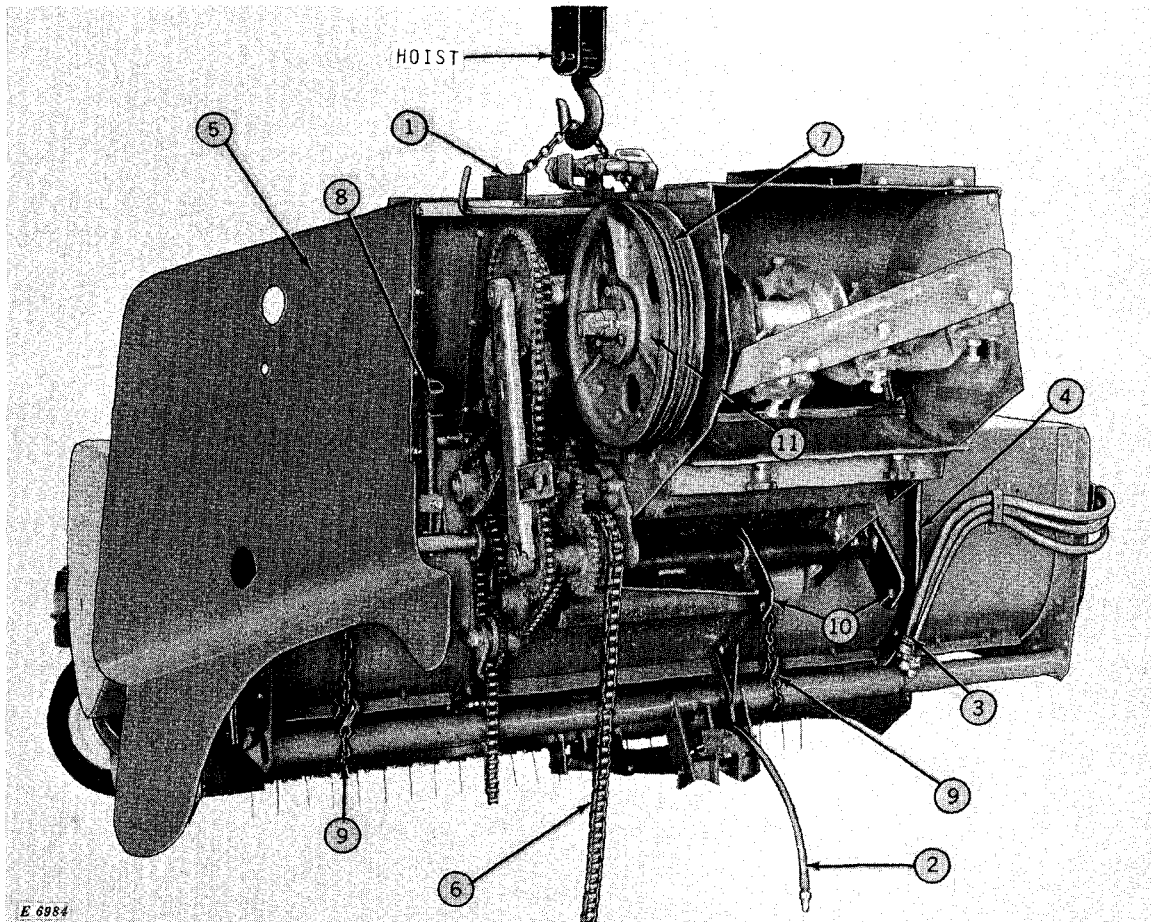

Fig. 2-Pickup and Cutterhead Separation

1. Remove platform front mounting bolts from both sides.
2. Disconnect lift cylinder hose.
3. Disconnect water hoses - code hoses for proper reinstallation.
4. Remove the four bolts through auger housing angle and right-hand frame extension.
5. Open pickup drive shield.
6. Remove pickup drive chain.
7. Remove cutterhead drive belt from cutterhead sheave.
8. Disconnect pickup variable speed control.
9. Place a lifting chain to the rear of the auger housing and anchor each end to the main cross pipe with one strand on each side of feeder. Put slight tension on the chain with a hoist.
10. Remove two bolts from feeder support to front axle assembly.
11. Remove the two bolts and clamp from each socket half at each cutterhead bearing (right-hand and left-hand side).

# Section 20

# ENGINE

## Group 5

## BASIC ENGINE

### GENERAL INFORMATION

The 400 and 425 Hay Cubers are powered by a General Motors Detroit Diesel 6V-71 Engine. This manual does not cover the testing or service of the engine. The engine must be serviced by a General Motors Detroit Diesel Engine distributor or dealer.

# Section 30 ELECTRICAL SYSTEM

## CONTENTS OF THIS SECTION

	Page		Page
GROUP 5 DESCRIPTION AND WIRING		Polarization .....	5-1
DIAGRAMS		Diagrams .....	5-2
General Information .....	5-1		

## Group 5 DESCRIPTION AND WIRING DIAGRAMS

### GENERAL INFORMATION

This is a 12-volt, positive grounded electrical system. It features one 12-volt 205 ampere battery, a 25 ampere generator, a voltage regulator, and a starter in addition to the wiring harnesses, lights, instruments, switches, and horn.

This text does not cover the testing or servicing of the generator, regulator, and starter. These items must be serviced by a Detroit Diesel dealer because they are supplied with the engine.



Refer to FOS Manual - ELECTRICAL SYSTEMS for additional information and testing precautions.

### POLARIZATION

After connecting the generator, regulator, starter, or battery, it will be necessary to polarize the generator if the system isn't charging.

With the engine not running, momentarily touch a wire to both the "GEN" and "BAT" terminals of the regulator to establish the correct polarity.