

# JD301-A TRACTOR AND LOADER

## TECHNICAL MANUAL

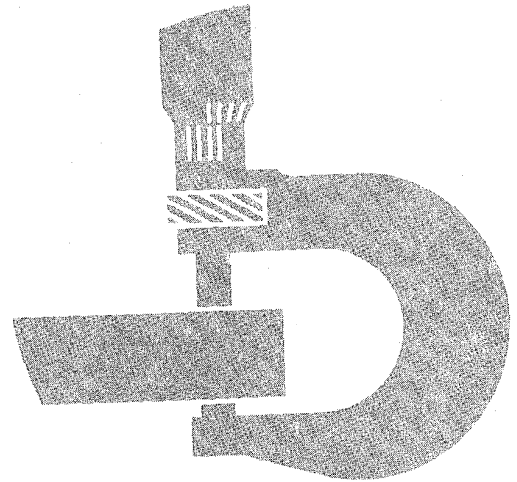

TM-1088 (Dec-78)  
LITHO IN U.S.A.

# JD301-A TRACTOR AND LOADER

Technical Manual  
TM-1088 (Dec-78)

## CONTENTS

- |   |   |
|---|---|
| Section 10 - GENERAL                                    | Section 50 - HYDRAULIC SYSTEM               |
| Group 5 Specifications                                  | Group 5 Transmission Pump                   |
| GROUP 10 Predelivery, Delivery, and After-Sale Services | Group 10 Main Hydraulic Pump                |
| Group 15 Lubrication                                    | Group 15 Reverser Clutch Control Valve      |
| Section 20 - ENGINE                                     | Group 20 Independent PTO Control Valve      |
| Group 5 Engine Removal and Installation                 | Group 25 Pressure Control Valve             |
| Group 10 Basic Engine                                   | Group 30 Power Steering Valve               |
| Group 15 Engine Lubrication System                      | Group 35 Manual Steering                    |
| Group 20 Engine Cooling System                          | Group 40 Brake Valve                        |
| Group 25 Fuel System                                    | Group 45 Loader Control Valve               |
| Group 30 Speed Control Linkage                          | Group 50 Selective Control Valve            |
| Group 35 Air Intake System                              | Group 55 Rockshaft System                   |
| Group 40 Specifications and Special Tools               | Group 60 Miscellaneous Hydraulic Components |
| Section 30 - ELECTRICAL SYSTEM                          | Group 65 Hydraulic Cylinders                |
| Group 5 Batteries                                       | Group 70 Specifications and Special Tools   |
| Group 10 Charging System                                | Section 60 - MISCELLANEOUS COMPONENTS       |
| Group 15 Starting System                                | Group 5 Manual Steering                     |
| Group 20 Ignition System                                | Group 10 Front End Assembly                 |
| Group 25 Gauges and Switches                            | Group 15 Loader Frame, Boom and Bucket      |
| Group 30 Specifications and Special Tools               | Group 20 3-Point Hitch                      |
| Section 40 - POWER TRAIN                                | Group 25 Specifications and Special Tools   |
| Group 5 Clutch Assemblies                               | Section 70 - SYSTEM TESTING                 |
| Group 10 Transmission                                   | Group 5 General Information                 |
| Group 15 Reverser                                       | Group 10 Engine                             |
| Group 20 PTO Systems                                    | Group 15 Electrical System                  |
| Group 25 Differential and Parking Brake                 | Group 20 Power Train                        |
| Group 30 Final Drives                                   | Group 25 Hydraulic System                   |
| Group 35 Specifications and Special Tools               | Group 26 Hydraulic System (Analyzer)        |
|   | Group 30 Miscellaneous Components           |
|   | Group 35 Specifications and Special Tools   |

## INDEX

*The specifications and design information contained in this manual were correct at the time it was printed. It is John Deere's policy to continually improve and update our machines. Therefore, the specifications and design information are subject to change without notice. Wherever applicable, specifications and design information are in accordance with SAE and ICED standards.*

Copyright © 1973  
DEERE & COMPANY  
Moline, Illinois  
All rights reserved

## INTRODUCTION

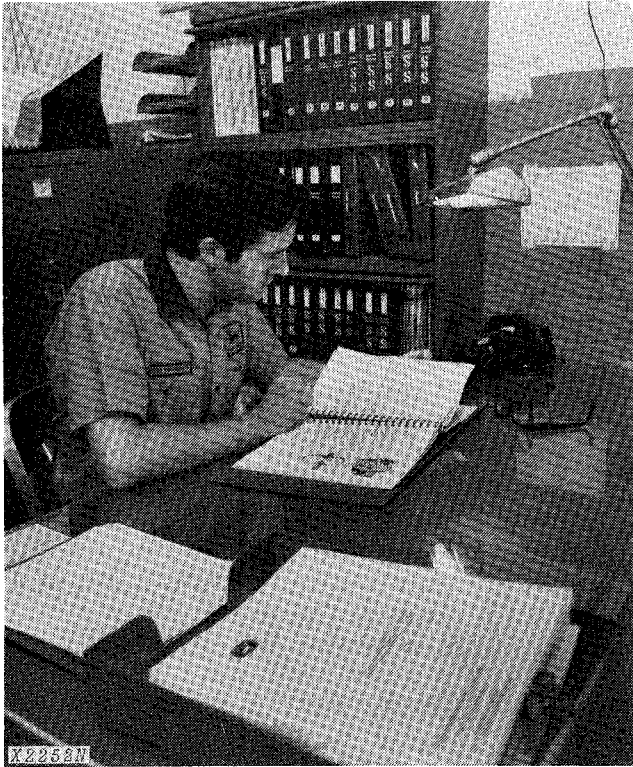

*Use FOS Manuals for Reference*

This technical manual is part of a twin concept of service:

The two kinds of manuals work as a team to give you both the general background and technical details of shop service.

### •FOS Manuals—for reference

*Fundamentals of Service (FOS) Manuals* cover basic theory of operation, *fundamentals* of trouble shooting, *general* maintenance, and *basic* types of failures and their causes. FOS Manuals are for training new personnel and for reference by experienced technicians.



When a service technician should refer to a FOS Manual for more information, a FOS symbol like the one at the left is used in the TM to identify the reference.

### •Technical Manuals—for actual service

*Technical Manuals* are concise service guides for a specific machine. Technical manuals are on-the-job guides containing only the vital information needed by an experienced service technician.

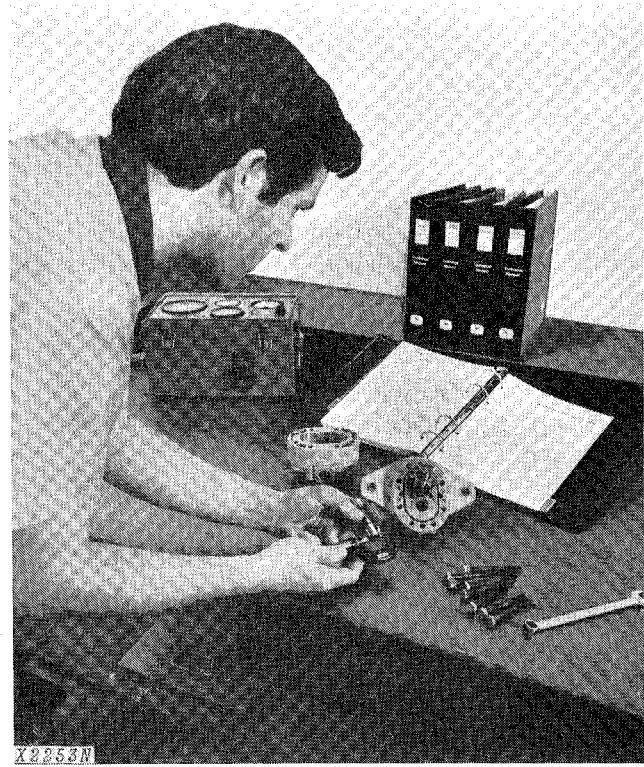

*Use Technical Manuals for Actual Service*

This technical manual was planned and written for you—an experienced service technician. Keep it in a permanent binder in the shop where it is handy. Refer to it whenever in doubt about correct service procedures or specifications.

Some features of this manual:

- Inside front cover - "Table of Contents" and "Maintenance Without Accident".
- Section 10 - General specifications and services.
- Sections 20 through 60 - Removal, repair, testing (components removed), installation, and adjustment.
- Section 70 - Detailed explanation of system operation, diagnosis, visual inspection, testing, and adjustments.
- Specifications grouped and illustrated at the end of each section.
- Inside rear cover—Index.

## MAINTENANCE WITHOUT ACCIDENT WORK SAFELY

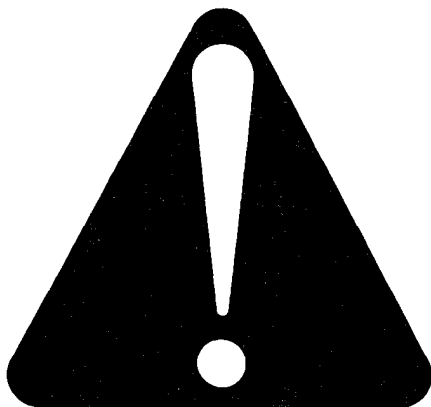

T27999N

 This safety alert symbol identifies important safety messages in this manual and on the tractor. When you see this symbol, be alert to the possibility of personal injury and carefully read the message that follows.

**EVERY EMPLOYER HAS A  
SAFETY PROGRAM. KNOW  
WHAT IT IS!**

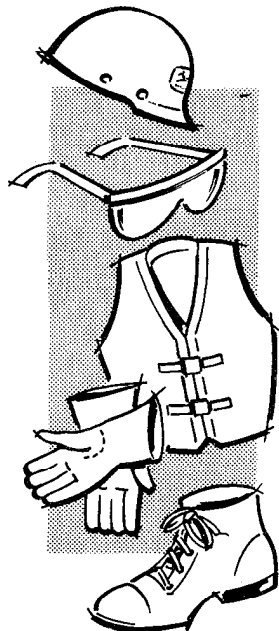

T27501N

Consult your shop foreman for specific instructions on a job, and the safety equipment required.

For instance, you may need: Hard hat, safety shoes, safety goggles, heavy gloves, reflector vests, ear protectors, respirators.

*Litho in U.S.A.*

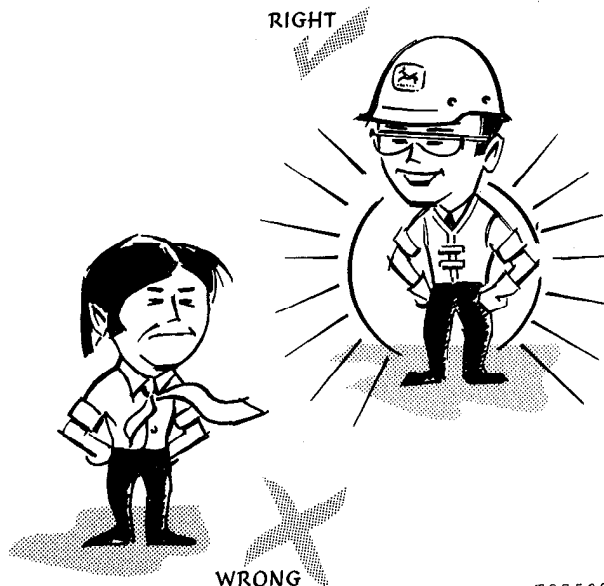

T27502N

### BE ALERT!

Plan ahead—work safely—know how to use a first-aid kit and a fire extinguisher—and where to get aid and assistance.

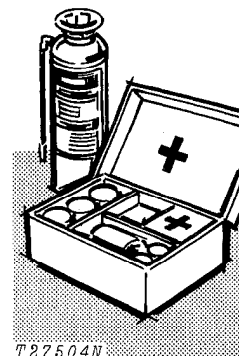

T27504N

### Maintenance Area

Make sure the maintenance area is adequately vented.

Keep maintenance area **CLEAN AND DRY**. Oily and wet floors are slippery; greasy rags are a fire hazard; wet spots are dangerous when working with electrical equipment.

Store starting aids in a cool and well-ventilated place, out of the reach of unauthorized personnel.

## MAINTENANCE WITHOUT ACCIDENT

### AVOID FIRE HAZARDS—

#### Fuel Is Dangerous!

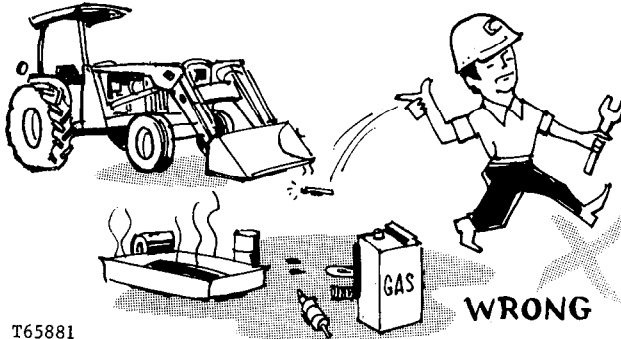

T65881

Don't smoke while refueling.

Don't smoke while handling highly flammable material.

Engine should be shut off when refueling.

Use care in refueling if the engine is hot.

Don't use open pans of gasoline or diesel fuel for cleaning parts. Good commercial, nonflammable solvents are preferred.

#### Battery Gas Is Highly Flammable!

Provide adequate ventilation when charging batteries.



T27506N

Don't check battery charge by placing metal objects across the posts.

Don't allow sparks or open flame near batteries.

Don't smoke near battery.

#### Flame Is Not a Flashlight!

**NEVER USE OPEN FLAME AROUND THE MACHINE.**

**KNOW WHERE FIRE EXTINGUISHERS ARE KEPT!**

### UNDER ALL MAINTENANCE CONDITIONS—

Do not perform any work on the equipment unless authorized to do so. Then be sure you know the safe and proper procedure.

Follow recommended procedures.

Never service the equipment while it is being operated.

Avoid working on equipment with the engine running.

#### RIGHT

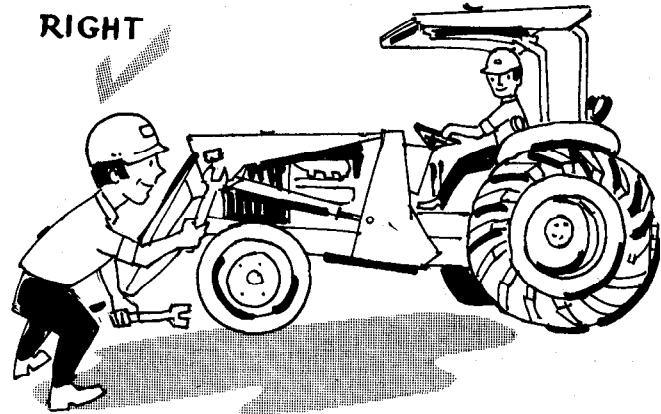

T65882

If it is necessary to make checks with the engine running, **ALWAYS USE TWO** service technicians—one, the operator, at the controls, the other checking within sight of the operator.

#### KEEP HANDS AWAY FROM MOVING PARTS

Support all raised equipment.

Never work under raised bucket.

Lower bucket to ground.

If the machine is on an incline, block it securely.

Use hoisting equipment for lifting heavy parts.

#### TAKE CARE! WATCH OUT FOR OTHER PEOPLE IN THE VICINITY

Wear safety glasses when drilling, grinding, or hammering metal.

## SERVICING PRECAUTIONS



Keep ALL equipment free of dirt and oil.

Be sure to clean any oil, grease, mud, ice, or snow from floor of operator's compartment and stepping points.

When preparing the engine for storage, remember that inhibitor is volatile and therefore dangerous. Seal and tape openings after adding the inhibitor. Keep container tightly closed when not in use.

Don't remove the radiator cap until coolant temperature is below the boiling point. Then loosen cap slowly to the stop to relieve pressure before removing.

Periodically check exhaust system for excessive leakage.

Relieve hydraulic pressure before working on hydraulic system: shut off engine, lower bucket to ground, and move control levers and steering wheel until no response is felt.

When checking hydraulic pressure, be sure to use the correct test gauge.

## PRECAUTIONS DURING REPAIR

Before working on hydraulic system relieve hydraulic pressure.

Before repairing the electrical system, or performing a major overhaul, disconnect batteries.

### KNOW EQUIPMENT IS READY!

Check guards, canopies, safety guards — all protective devices installed on the unit. Every one should be in place and secure.

### CHECK IT OUT!

- GUARDS
- CANOPIES
- SHIELDS
- PROTECTIVE DEVICES
- ROLL-OVER PROTECTIVE STRUCTURES
- SEAT BELTS, ETC.

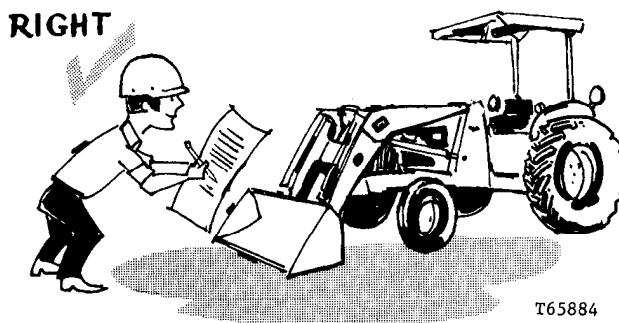

Carefully inspect equipment for visual defects—leaks in fuel, lubrication, and hydraulic systems. Do not search for pressurized fluid leaks with your hands. Use cardboard or wood to search for leaks.

# Section 10 GENERAL

## CONTENTS OF THIS SECTION

	Page		Page
GROUP 5 - SPECIFICATIONS		GROUP 15 - LUBRICATION	
General Machine Specifications .....	5-1	Oils and Greases .....	15-1
GROUP 10 - PREDELIVERY, DELIVERY, AND AFTER-SALE SERVICES			
Temporary Machine Storage .....	10-1		
Predelivery Service .....	10-1		
Delivery Service .....	10-12		
After-Sale Inspection .....	10-12		

## Group 5

# GENERAL MACHINE SPECIFICATIONS

(Specifications and design subject to change without notice. Wherever applicable, specifications are in accordance with ICED and SAE Standards. Except where otherwise noted, these specifications are based on a unit equipped with 14.9-24, 6 ply rating rear tires, 6.00-16, 6 ply rating front tires; 3/4 cu. yd. (0.57 m<sup>3</sup>) bucket; and standard equipment.)

<b>Power</b> (@2500 engine rpm):	<b>SAE</b>	<b>DIN</b>
Gross .....	46 hp (34.3 kW*)	
Net .....	43 hp (32.1 kW)	45.7 PS

Net engine flywheel power is for an engine equipped with fan, air cleaner, water pump, lubricating oil pump, fuel pump, alternator, and muffler. Gross engine power is without fan. Flywheel power ratings are under SAE standard conditions of 500 ft. altitude and 85°F temperature and DIN 70 020 standard conditions of 760 mm Hg barometer (sea level) and 20°C temperature. \*In the International System of Units (SI), power is expressed in kilowatts (kW).

**Engine:** John Deere 3-cylinder diesel, valve-in-head, 4-stroke cycle

Bore and stroke .....	3.86x4.33 in. (98x110 mm)
Piston displacement .....	152 cu. in. (2491 cm <sup>3</sup> )
Compression ratio .....	16.2 to 1
Maximum torque @ 1,300 rpm .....	110 lb-ft (149 Nm) (15.2 kg-m)
NACC or AMA (U.S. Tax) horsepower .....	17.88
Main bearings .....	4
Lubrication .....	Pressure system w/full flow filter
Cooling .....	Pressurized w/thermostat and fixed bypass
Fan .....	Suction
Air cleaner .....	Dry
Electrical system .....	12 volt w/alternator
Battery (12 volt) reserve capacity .....	60 minutes      110 minutes

**Engine Clutch**...Foot-operated: single 10 in. (254 mm) plate w/reverser; single 11 in. (280 mm) plate w/o reverser

**Transmission**....Constant mesh, 8 forward speeds, 4 reverse with helical gears and sliding collars; mechanical shuttle. Optional hydraulic direction reverser provides 8 speeds forward and 8 reverse; hydraulic wet clutches, no clutching required.

<b>Gear:</b>	<b>Travel Speeds:</b>				
		mph		km/h	
	Fwd.	Rev.	Fwd.	Rev.	
1	1.3	1.6	2.1	2.6	
2	1.9	2.2	3.1	3.5	
3	2.9	3.3	4.7	5.3	
4	4.0	4.7	6.4	7.6	
5	5.3	6.2	8.5	10.0	
6	7.6	8.8	12.2	14.2	
7	11.2	13.0	18.0	20.9	
8	15.7	18.3	25.3	29.4	

**Final Drives**..... Inboard, planetary

**Brakes**...Hydraulically actuated, fully enclosed, wet-disk. Self-equalizing. Foot-operated individually or simultaneously.

**Steering**..... Manual  
 Turning radius (brake applied) ..... 10 ft. 2 in. (3.10 m)

Loader clearance circle, dia.

(brake applied) ..... 32 ft. (9.75 m)

Number of turns, far left to far right ..... 3.3

**Hydraulic System:** Closed-center  
 Max. pressure 2350 psi (16 203 kPa) (165.2 kg/cm<sup>2</sup>)  
 Loader control..... 2-lever  
 Pump ..... Piston, constant pressure, variable-displacement, 13 gpm (49 L/min) @ 2500 engine rpm

**Hydraulic**

<b>Cylinders:</b>	<b>Bore</b>	<b>Stroke</b>
Boom	2.25 in. (57 mm)	33.28 in. (845 mm)
Bucket	2.25 in. (57 mm)	24.56 in. (624 mm)
Cylinder rods	Ground, heat-treated, chrome-plate, polished	
Boom cylinder rods	1.5-in. (38 mm) dia.	
Bucket cylinder rods	1.25-in. (32 mm) dia.	

<b>Tires:</b>	<b>Front</b>	<b>Rear</b>
Turf	27-9.50-15, 6 ply rating, I1 Terra-tires	18.4-16A, 6 ply rating, R3
	27-9.50-15, 10 ply rating, I1 Terra-tires	

Utility	6.50-16, 6 ply rating, I1	13.6-28, 4 ply rating, R1
	11L-15, 8 ply rating, F3	14.9-24, 6 ply rating, R4
	7.50/8.00-16, 6 ply rating F3	14.9-24, 6 ply rating, R3
		14.9-24, 6 ply rating, R1
		16.9-24, 6 ply rating, R3
		17.5L-24, 8 ply rating, R4

**Wheel Treads** (dependent on tires and front axle):  
 Front ..... 49 to 74 in. (1.25 to 1.88 m)  
 Rear ..... 48 to 76 in. (1.22 to 1.93 m)

<b>Capacities:</b>	<b>U.S.</b>	<b>Liters</b>
Cooling system	3 gal.	11.4
Fuel tank	19.5 gal.	73.8
Engine lubrication, including filter	6 qt.	5.7
Transmission and hydraulic system	10 gal.	37.9

**Dimensions:**

Height to top of hood	4 ft. 7 in. (1.40 m)
Overall height to top of muffler	6 ft. 5 in. (1.90 m)
Overall height to top of canopy	7 ft. 2 in. (2.18 m)
Overall width w/60 in. tread width	6 ft. 3 in. (1.90 m)
Overall length	15 ft. 1.5 in. (4.61 m)
Overall length w/3-point hitch	16 ft. 2.5 in. (4.94 m)
Wheelbase	74.4 in. (1.89 m)
Ground clearance (under front axle)	1 ft. 5 in. (430 mm)
Ground clearance, min.	11 in. (280 mm)

**Additional Standard Equipment:**

- Oil pressure indicator light
- Alternator charge indicator light
- Coolant temperature gauge
- Fuel gauge
- Speed-hour meter
- Horn
- Key switch safety start
- Cushioned seat
- Vertical muffler w/rain cap
- Transistorized voltage regulator
- Fenders
- Antifreeze
- Two-position disk rear wheels
- 3/4 cu. yd. (0.57 m<sup>3</sup>) loader bucket
- Air cleaner restriction indicator
- Cigar lighter
- Cold weather starting aid

**SAE Operating Weight** ..... 6120 lb. (2 776 kg)



### DIMENSIONS

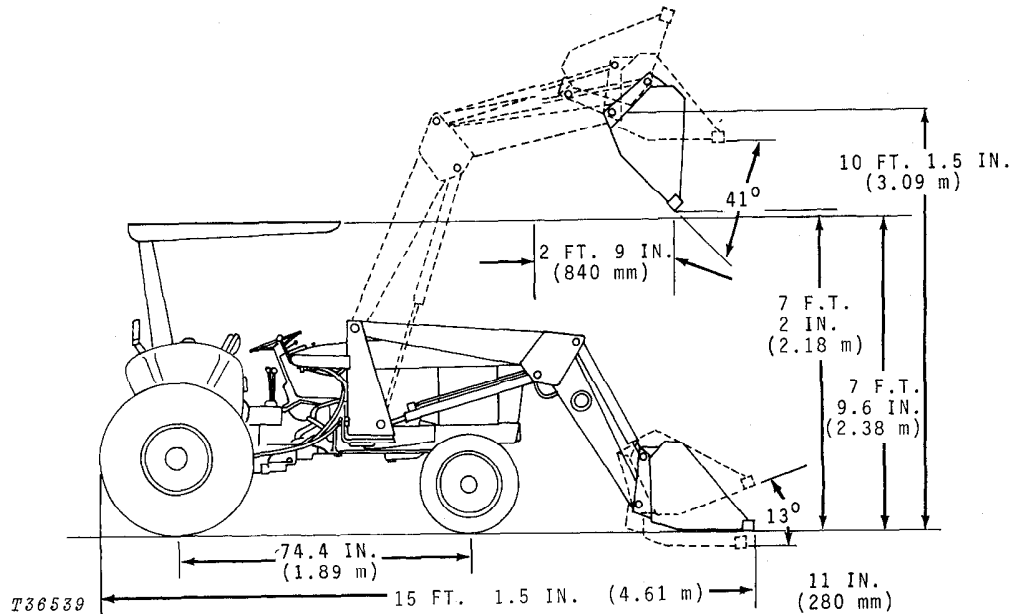

#### Special Equipment:

- Batteries (2); reserve capacity 220 minutes
- Deluxe seat
- Differential lock
- Fixed front axle
- Foot throttle
- Front grille guard
- Hydraulic direction reverser
- Lights
- Mid PTO (1000 rpm "live," w/rear PTO)
- Muffler extension (vertical muffler)
- Parking brake
- Power steering
- Rear muffler
- Rear PTO (continuous "live" or independent 540 rpm)
- Remote hydraulic cylinder
- ROPS and seat belt, w/ or w/o canopy
- Single or dual remote-cylinder control w/quick-connect couplers
- Swinging drawbar
- 3-inch seat belt
- 3-point hitch (Category 1 or 2 w/sway blocks and regular or short links)
- Toolbox

#### LOADER SPECIFICATIONS

Buckets:	Nominal Heaped Capacity	Width
3/4 cu. yd. (0.57 m <sup>3</sup> )		73.8 in. (1.88 m)

#### Operating Information:

Breakout force...	4000 lb. (17.92 kN) (1814 kg)
Lifting capacity, full height...	2500 lb. (1134 kg)
Raising time to full height .....	5.1 sec.
Bucket dump time .....	2.9 sec.
Lowering time (power) .....	3.0 sec.
Rollback time .....	2.6 sec.
Float-down time .....	6.1 sec.
Recommended rear ballast .....	2000 lb. (910 kg)

# Group 10 PREDELIVERY, DELIVERY, AND AFTER-SALE SERVICES

## TEMPORARY UNIT STORAGE

After receiving your unit from the factory and before putting the machine into temporary storage, perform the following checks and services.

For long term storage (over 30 days) information, consult your JD301-A operator's manual.

1. Check battery electrolyte level and charge the battery, if necessary.
2. Check engine coolant level. Maintain midway between the radiator core and filler neck.
3. Fill the fuel tank.
4. Check crankcase oil level. Oil must be between marks on dipstick after machine has been shut down for 10 minutes.
5. Relieve hydraulic pressure by stopping engine, lowering bucket and operating control levers and steering wheel until system fails to respond.
6. Reduce shipping pressure of all tires to the inflation pressure listed on page 10-10-2.

## PREDELIVERY SERVICE

Because of the shipping factors involved, plus extra finishing touches that are necessary to promote customer satisfaction, proper predelivery service is of prime importance to the dealer and the customer.

Use the following list when preparing a unit for delivery to the customer.

## 1. Air Cleaner

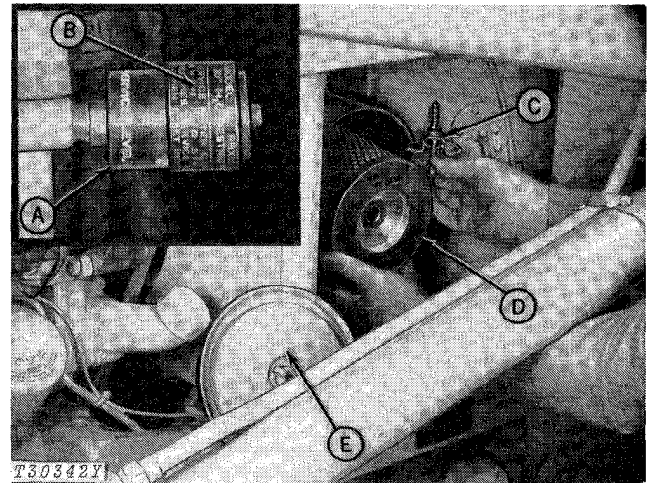

A—Restriction Indicator      D—Element  
B—Red Signal                  E—Cover  
C—Wing Nut

Fig. 1-Air Cleaner

Check air filter restriction indicator (A). If red signal can be fully seen, remove element (D) and clean. Install a new element if necessary.

Element checked Yes    No

## 2. Radiator

Check engine coolant level.

**CAUTION:** Do not remove radiator filler cap unless the engine is cool. Then loosen the cap slowly to the stop to relieve pressure before removing the cap.

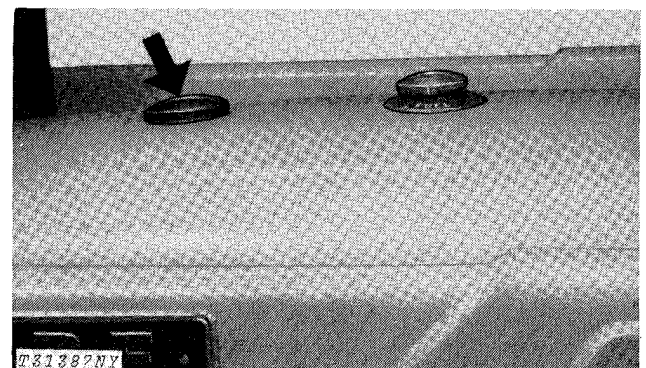

Fig. 2-Radiator Filler Cap

Maintain coolant level midway between the radiator core and the filler neck. If needed add clean soft water for warm weather, or a solution of 50% clean water and 50% ethylene glycol (permanent type antifreeze with approved rust inhibitor) for cold weather.

Check cooling system for loose connections and leaks.

Coolant level checked Yes No

### 3. Battery

Check battery electrolyte level. If distilled water is not available, use clean soft water. Avoid use of hard water. Remove foreign material from top of battery and coat terminals with petroleum jelly. Check vent holes in battery caps.

**IMPORTANT: Never add water to battery in freezing weather unless engine will be run 2 or 3 hours.**

Punch date code on battery.

### 4. Tire Pressure

Check tire pressure with an accurate gauge having 1 psi (0.07 bar) graduations.

Inflate tires according to the chart below.

Battery checked Yes No

#### FRONT TIRE INFLATION

##### Inflation Pressure

Tire Size	Type	PR	Inflation Pressure		
			With Towed or Rear-Mounted Equipment	With Light Front-Mounted Equipment	With Heavy Front-Mounted Equipment
6.50-16	I-1	6	36 psi (2.5 bar)	40 psi (2.8 bar)	48 psi (3.3 bar)
7.50/8.00-16	F-3	6	28 psi (1.9 bar)	32 psi (2.2 bar)	36 psi (2.5 bar)
27x9.50-15	I-1	6	35 psi (2.4 bar)	40 psi (2.8 bar)	Do not use
27x9.50-15	I-1	10	55 psi (3.8 bar)	60 psi (4.1 bar)	65 psi (4.5 bar)
11L-15	F-3	8	40 psi (2.8 bar)	40 psi (2.8 bar)	40 psi (2.8 bar)

#### REAR TIRE INFLATION

##### Inflation Pressure

Tire Size	PR	Inflation Pressure		
		With Little Ballast or No Rear-Mounted Equipment	With Moderate Ballast or Light Rear-Mounted Equipment	With Maximum Ballast or Heavy Rear-Mounted Equipment
13.6-28	4	14 psi (1.0 bar)	14 psi (1.0 bar)	Do not use
14.9-24	6	14 psi (1.0 bar)	16 psi (1.1 bar)	18 psi (1.2 bar)
16.9-24	6	18 psi (1.2 bar)	20 psi (1.4 bar)	22 psi (1.5 bar)
17.5L-24	8	24 psi (1.7 bar)	24 psi (1.7 bar)	24 psi (1.7 bar)
18.4-16A	6	14 psi (1.0 bar)	14 psi (1.0 bar)	Do not use

Tire pressure checked Yes No

### 5. Crankcase Oil Level

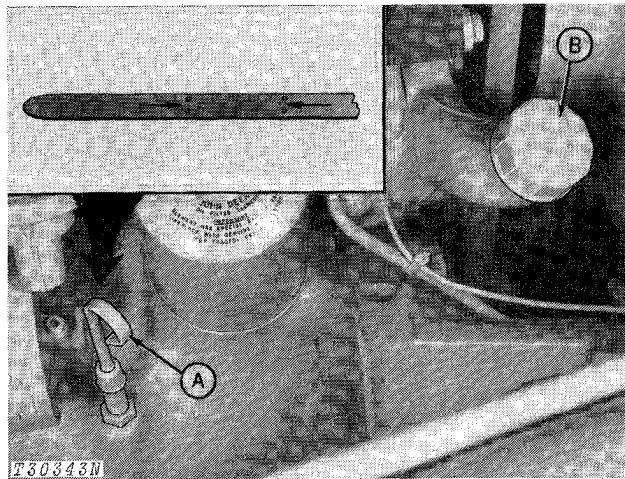

A—Dipstick

B—Oil Filler Cap

Fig. 3-Crankcase Oil Level

Check crankcase oil level with machine on level ground. (Allow a minimum of 10 minutes for the oil to drain down before checking.) If oil level is at or below bottom mark on dipstick, add oil specified on page 10-15-1 to bring oil level to between marks on dipstick. Do not operate engine with oil level below the bottom mark.

Crankcase oil level checked	Yes	No
Oil added		qts. (L)

### 6. Transmission Oil Level

Check transmission-hydraulic oil level.

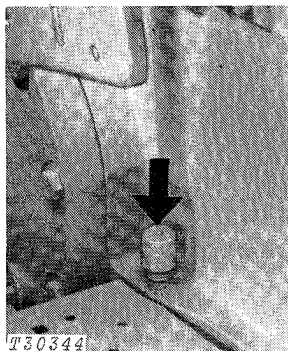

Fig. 4-Transmission-Hydraulic System Dipstick Resting On Top Threads

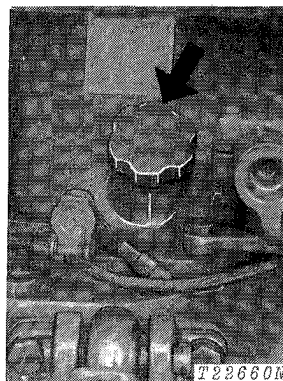

Fig. 5-Transmission-Hydraulic System Filler Cap

Run engine two to three minutes to fill oil circuits. Check oil level with machine on level ground, engine running at slow idle, rockshaft and any equipment lowered, reverser lever (if equipped) locked in neutral, parking brake engaged (if equipped), range shift lever in park, and clutch engaged. Remove dipstick and wipe off oil. Insert dipstick with cap resting on threads of tube (not screwed in place). If oil level is down to bottom mark on dipstick, add oil. Remove filler cap on rockshaft housing and add oil specified on page 10-15-1 to bring oil level to top mark on dipstick.

Oil level checked	Yes	No
Oil added		qts. (L)

### 7. Fuel Tank

Fill fuel tank with correct fuel. Check action of fuel gauge.

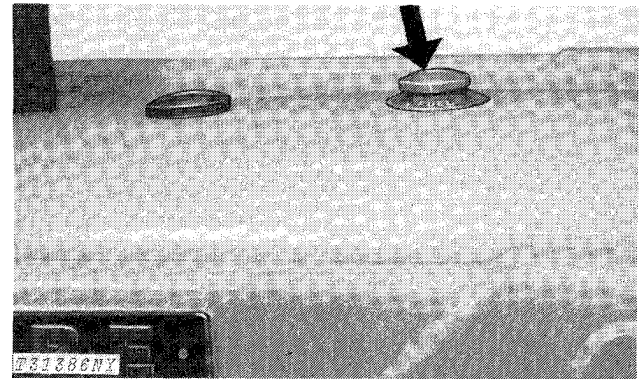
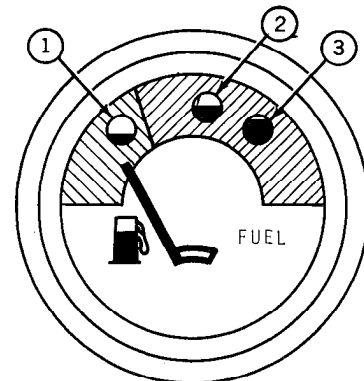

Fig. 6-Fuel Tank Filler Cap



1—Empty Tank

2—Half Full Tank

3—Full Tank

Fig. 7-Fuel Gauge

Fuel tank filled	Yes	No
Fuel gauge checked	Yes	No

### 8. Grease Fittings

All grease fittings were lubricated and checked before the unit left the factory. However, to insure customer satisfaction, check each fitting shown. Lubricate, if necessary, with John Deere Multi-Purpose Grease or an equivalent.

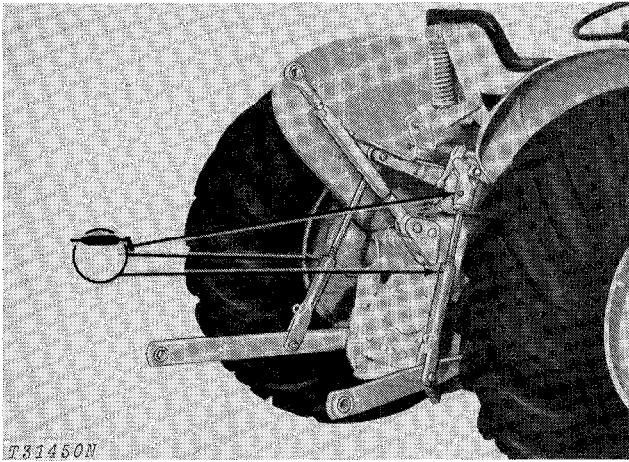

Fig. 8-3-Point Hitch (3 points)

Lubrication required                      Yes      No

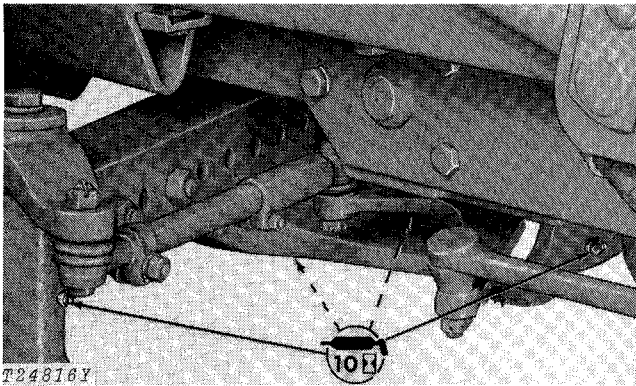

Fig. 9-Front Axle Pivot Points (4 points)

Lubrication required                      Yes      No

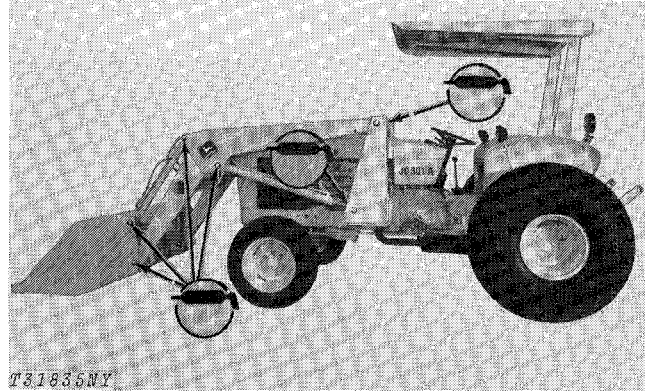

Fig. 10-Loader Pivot Points (12 points)

Lubrication required                      Yes      No

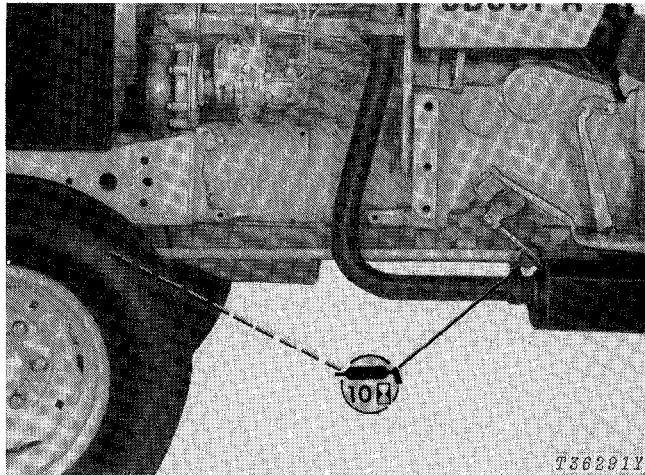

Fig. 11-Drag Links (2 points)

Lubrication required                      Yes      No

## 9. Air Intake Hoses

Check clamps on hoses connecting air cleaner and engine. Tighten hose clamps where necessary. Inspect hoses for cracks.

Intake hoses checked Yes No

## 10. Alternator - Fan Belt Tension

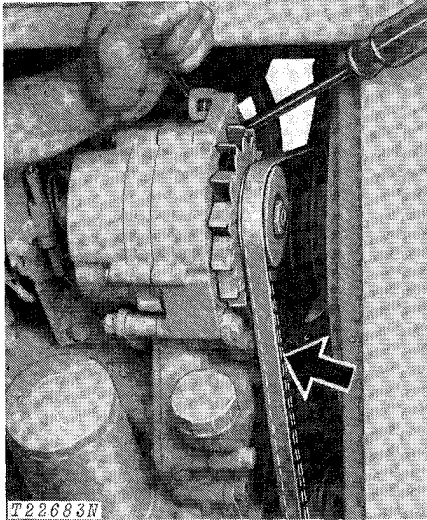

Fig. 12-Alternator - Fan Belt Tension

Check alternator-fan belt tension. Loosen the alternator bracket and adjusting cap screws. Apply outward force to the FRONT alternator frame until 20 lb (9 kg) force on the belt midway between the pulleys will deflect the belt 3/4 inch (19 mm). If a tension gauge is used, strand tension must be 90 lb (41 kg).

**IMPORTANT: Do not pry on the rear of the alternator housing.**

Belt tension checked Yes No

## 11. Engine Speeds

Check engine speeds.

Slow idle - 825 rpm  
Fast Idle - 2650 rpm hand throttle  
2800 rpm foot throttle

If adjustment is needed, see page 10-10-18.

Engine speeds checked Yes No

## 12. Fuel Filter

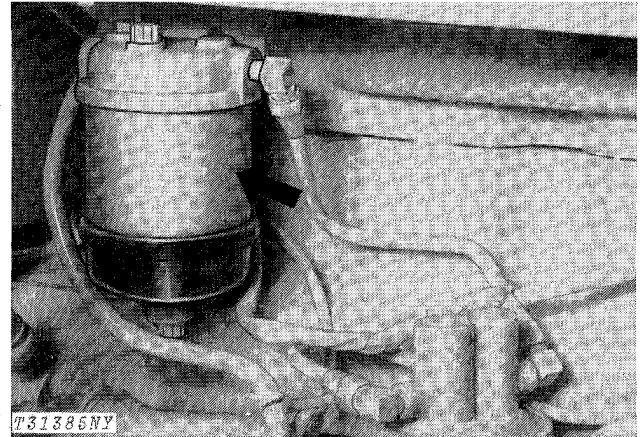

Fig. 13-Fuel Filter

Check fuel filter for sediment. Drain if necessary.

Fuel filter checked Yes No

### 13. Indicator Lights and Gauges

Check operation of indicator lights.

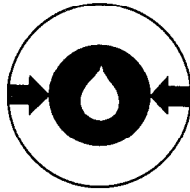

T22738

Fig. 14-Engine Oil Pressure Indicator Light

If light glows red when engine is running, stop engine immediately and determine cause.

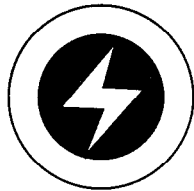

T22737

Fig. 15-Alternator Indicator Light

Light glows red when alternator is not charging. When light goes on with engine running, stop engine and determine cause.

Check operation of the engine coolant temperature gauge.

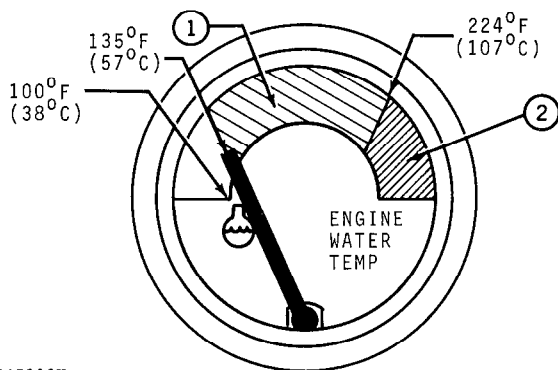

T43920N

1—Operation Range                      2—Overheat Range

Fig. 16-Coolant Temperature Gauge

If the indicator hand goes into the red-orange zone, stop the engine. Check the cooling system.

**NOTE:** Fuel gauge is on page 10-10-3.

Indicator lights and gauges checked                      Yes      No

### 14. Reverser

Check the reverser operation.

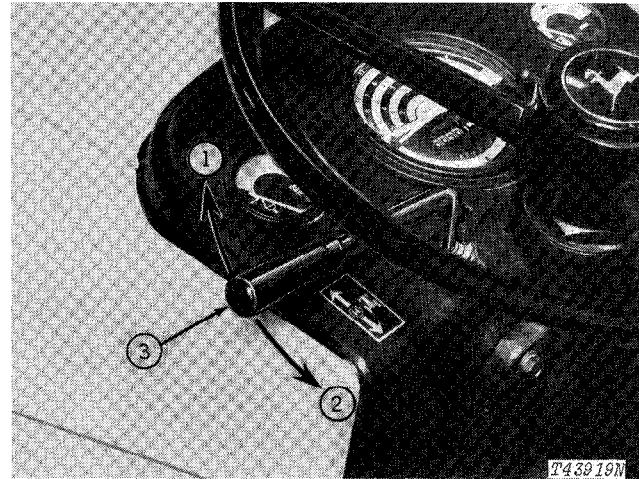

1—Forward                      2—Reverse                      3—neutral

Fig. 17-Reverser Lever

The reverser unit allows the operator to change the direction of travel "on the go" without declutching or shifting gears.

Note and correct any reverser malfunctions.

See page 10-10-20 for reverser speed-of-shift adjustment.

Reverser checked                      Yes      No

### 15. Differential Lock

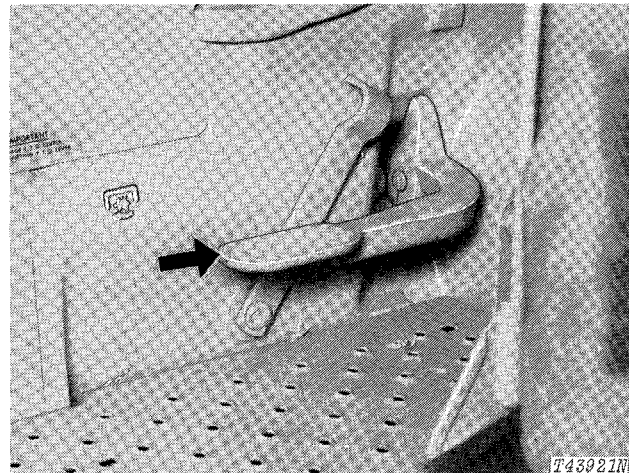

Fig. 18-Differential Lock Pedal

Check the differential lock operation.

While driving straight ahead, push down the differential lock pedal. Hold the pedal down. Turn the steering wheel slightly. There will be steering resistance if the differential lock is working correctly.

The differential lock will automatically disengage when the pedal is released if traction for both rear wheels is equal. Unequal traction will keep the lock engaged.

Differential lock checked Yes No

## 16. Transmission Shifting

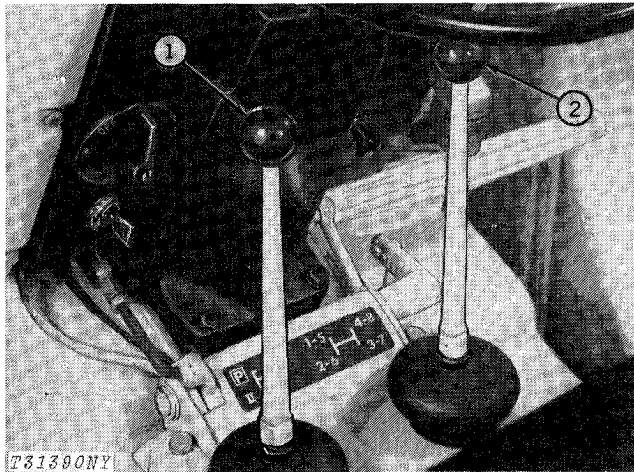

1—Range Shift Lever

2—Gear Shift Lever

Fig. 19-Transmission

Check the operation of the unit in all ranges and gears.

Correct any malfunctions.

Transmission shifting checked Yes No

## 17. Brakes

Check operation of brakes.

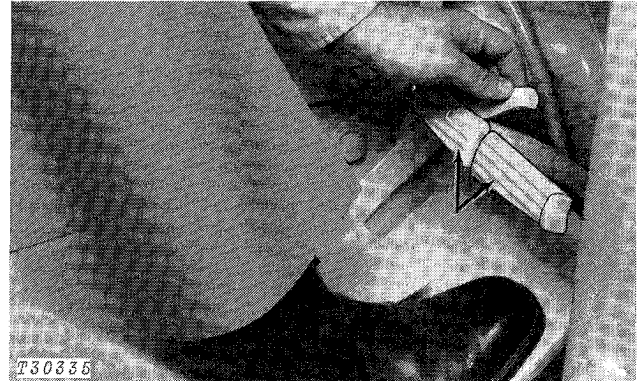

Fig. 20-Hydraulic Brakes

To stop the machine, push down both brake pedals. The machine must not pull to one side when stopping.

Turn to the left (L.H.). Push down the left (L.H.) brake pedal as you turn. Turn to the right (R.H.). Push down the right (R.H.) pedal as you turn.

The operator must feel the braking action pulling the machine to the left (L.H.) or right (R.H.). Brake action must be the same for both brakes.

Hydraulic brakes checked Yes No

## 18. Clutch Pedal Free Travel

### Without Reverser (with continuous PTO)

Check the free travel of the clutch pedal. Free travel (1, Fig. 21) must be 1/2 in. (13 mm) to 1 in. (25 mm).

**IMPORTANT: Do not operate the machine when the free travel of the clutch pedal is less than 1/2 inch (13 mm).**

See page 10-10-22 for adjustment of free travel.

### Without Reverser (with no PTO or with independent PTO)

Push the clutch pedal down until the clutch fingers contact the throwout bearing. Measure the distance from the pedal arm to where the pedal arm contacts the pedal stop. This distance must be 5 in. (127 mm).

If adjustment is needed, see page 10-10-22.



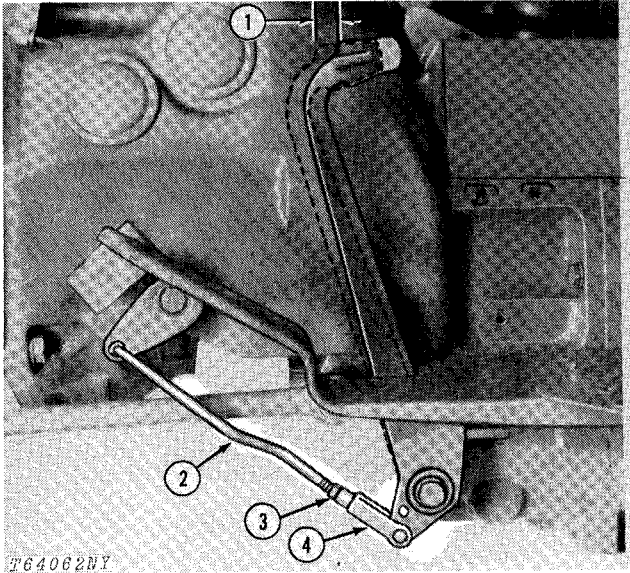

1—Specified Free Travel      3—Jam Nut  
 2—Clutch Rod                    4—Yoke

Fig. 21-Clutch Pedal Free Travel  
 (Without Reverser)

**With Reverser**

Check the free travel of the clutch pedal. Push the pedal down to the bottom of the first stage detent. In this position the throwout bearing will be against the clutch fingers. The top right (R.H.) edge of the rear of the pad of the clutch pedal must be 5-1/4 in. (133 mm) to 5-3/4 in. (146 mm) from the front of the bolting flange of the clutch housing. See 1, Fig. 22.

If free travel is more than 5-3/4 in. (146 mm), see page 10-10-22 for adjustment.

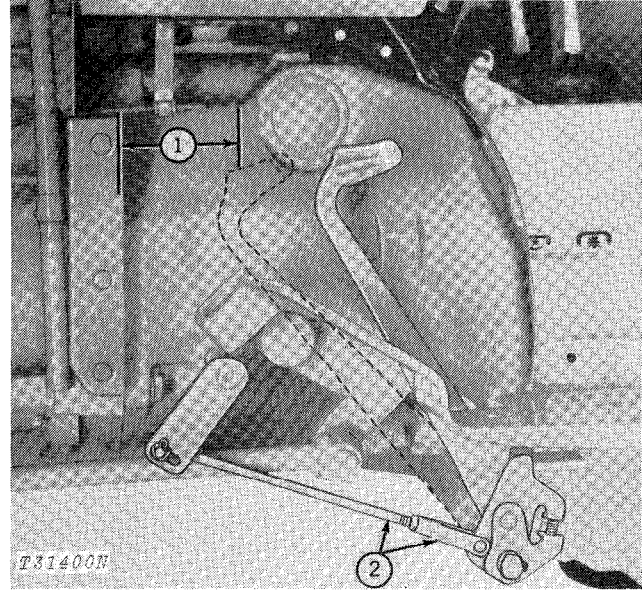

1—5-1/4 inches (133 mm) to 5-3/4 (146 mm)  
 2—Pedal Adjusting Rod and Yoke

Fig. 22-Clutch Pedal Free Travel  
 (With Reverser)

Free travel checked Yes    No

**19. Engine Crankcase Vent Tube**

Remove the vent tube. Clean it with diesel fuel. Install the vent tube. Be sure the packing fits correctly in the tappet cover.

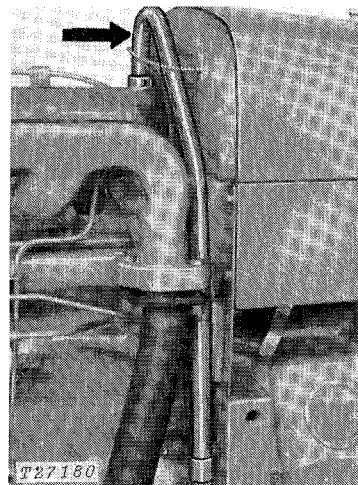

Fig. 23-Crankcase Vent Tube

Vent tube cleaned Yes    No

## 20. Seat

Check the operation of the seat.

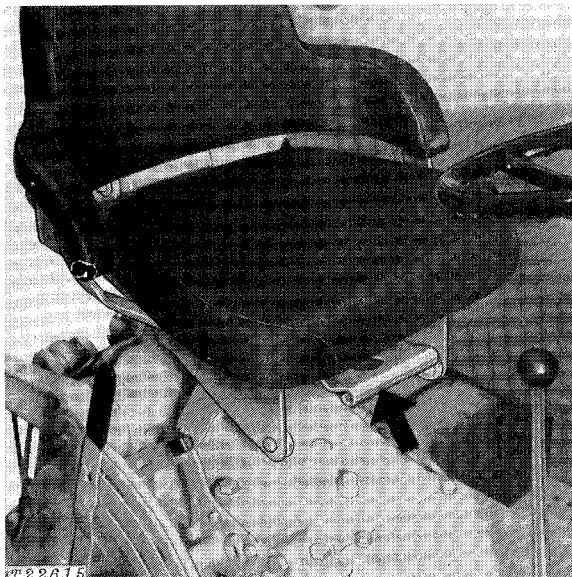
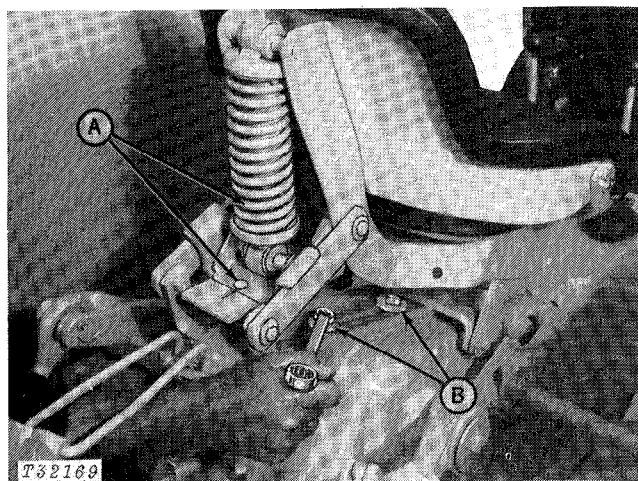

Fig. 24-Seat Release Latch (Deluxe Seat)

To move the seat to the upper rear position for standing, lift the release latch (Fig. 24). Stand. Lift the seat to the upper rear position.

To move the seat back to normal position, pull the seat forward. The seat will automatically go back to normal position when you sit.



A—Weight Adjustment

B—Height Adjustment

Fig. 25-Seat Adjustments

To change the adjustment for the height of the seat, loosen the cap screws (B, Fig. 25). Slide the seat to the desired position. Tighten the cap screws thoroughly.

To change the adjustment for the weight of the operator, move the seat to the upper rear position. Loosen the wing nuts under the support for the shock absorber. Slide the support to the desired position. Tighten the wing nuts.

Seat operation checked Yes No

## 21. Power Steering

Check the operation of the power steering. The steering wheel must turn freely in both directions without seizure or too much play.

Power steering checked Yes No

## 22. Power Take-Off

Check power take-off operation.

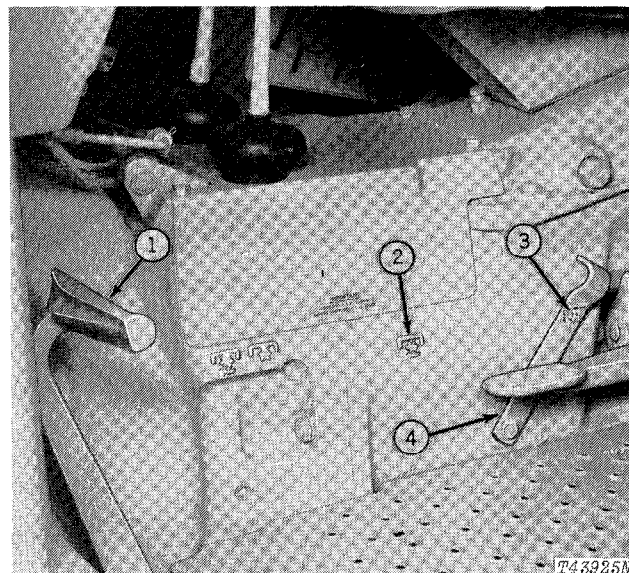

1—PTO Clutch  
 2—On

3—Off  
 4—PTO Lever

Fig. 26-PTO Operation

**IMPORTANT:** Disengage PTO clutch at pedal before shifting PTO selector lever. PTO lever must be in fully engaged or "ON" position to avoid excessive spline wear.

### Continuous-Running PTO

To engage the PTO, completely depress the clutch pedal (momentarily wait for machine motion to stop). Move the PTO selector lever to the "ON" position. Slowly engage the clutch pedal.

**Thank you very much for  
your reading. Please Click  
Here. Then Get COMPLETE  
MANUAL. NO WAITING**



**NOTE:**

**If there is no response to  
click on the link above,  
please download the PDF  
document first and then  
click on it.**

To disengage the PTO, completely depress the clutch pedal. Shift the selector lever to the "OFF" position.

**IMPORTANT: Always disconnect rear PTO stub shafts when not in use.**

PTO operation checked Yes No

### 23. Loader Control Levers

Check the operation of the loader control levers.

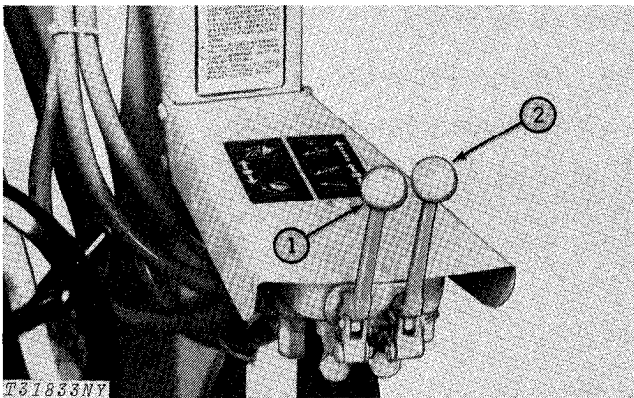

1—Bucket Control Lever 2—Boom Control Lever

Fig. 27-Loader Control Levers

**CAUTION:** Reduce boom lift speed when raising loaded bucket to full height.

#### Boom Lever

Push the lever forward to lower the boom. Pull the lever rearward to raise the boom.

If the lever is released during normal loader operation, it will return to neutral. The boom will be held in the position reached at that time.

Push the boom control lever all the way forward for float position. The lever will stay in this position until it is manually returned to neutral.

#### Bucket Lever

Push the lever forward to dump the bucket. Pull the lever rearward to retract the bucket.

If the lever is released, it will return to neutral. The bucket will be held in the position reached at that time.

Loader control levers checked Yes No

### 24. Hand Throttle

Check operation of hand throttle.

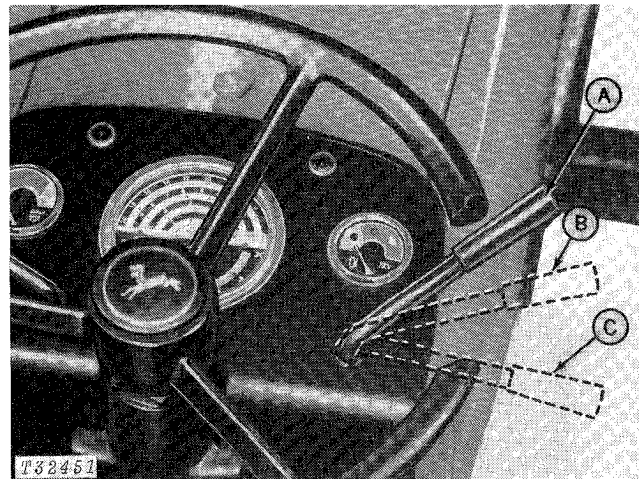

A—Slow Idle B—PTO Speed C—Fast Idle

Fig. 28-Hand Throttle

Hand throttle checked Yes No

### 25. Lights

Check the operation of the lights.

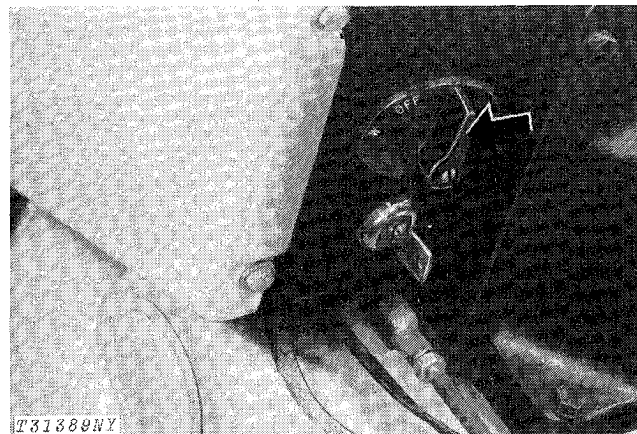

Fig. 29-Light Switch

Position	Headlights	Warning Lamps	Rear Combination Light
OFF	Off	Off	Off
W		On	
F	Dim		White
H	Bright	On	Red
H2	Dim	On	Red

**NOTE:** If customer desires, wire the lights to turn on when the key switch is off. Remove the purple wire from the "BAT" terminal. Install the unused red wire coming from the circuit breaker. Tape the end of the purple wire.

All lights checked Yes No

## 26. Parking Brake

Check the operation of the parking brake.

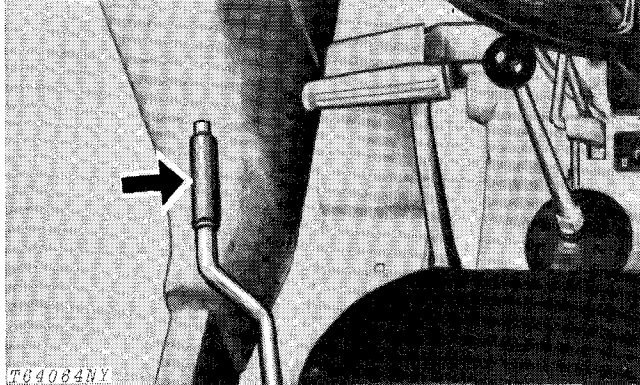

Fig. 30-Parking Brake

1. To engage, pull up.
  2. To disengage, press button and push lever down.
- If adjustment is needed, see page 10-10-25.

Parking brake checked Yes No

## 27. Toe-In

Check the front wheel toe-in.

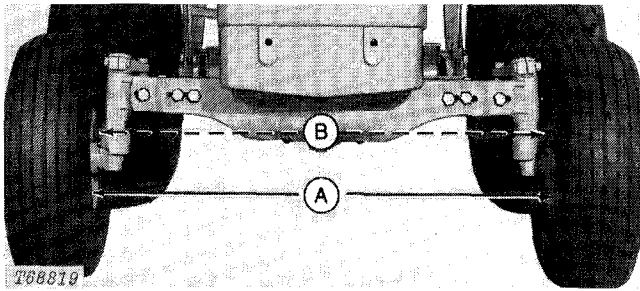

A—Distance Between  
Front of Rims

B—Distance Between  
Rear of Rims

Fig. 31-Checking Toe-In

1. Use down pressure of loader bucket to raise front wheels. Turn wheels so each valve stem is at bottom of tire.

2. Lower wheels to ground.
3. Measure from ground to hub.
4. Mark this distance on inside of each rim at the bead of tire front (A) and rear (B).
5. Measure distance between rims at front and rear marks.
6. Distance between front of rims must be 1/8 to 3/8 in. (3 to 9.5 mm) less than distance between rear of rims.

If adjustment is needed, see page 10-10-27.

Toe-in checked Yes No

## 28. Wheel Retainers

Check the torque of the wheel retainers.

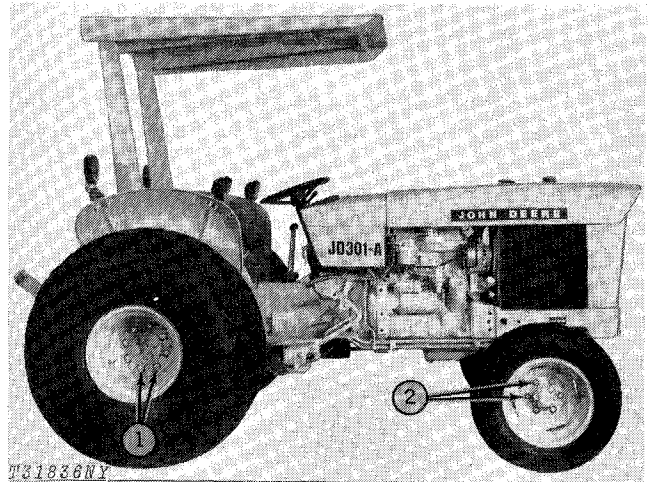

1—Rear Wheel Retainer

2—Front Wheel Retainer

Fig. 32-Wheel Retainers

Tighten front and rear wheel retainers to 100 lb-ft (14 kg-m).

Wheel retainers checked Yes No

## 29. Accessible Hardware Torque Values

Check all accessible bolts and nuts for correct tightness. If any bolts or nuts are loose, tighten them to the correct torque. See the torque chart on page 10-10-28.

Accessible hardware checked Yes No

## 30. Final Check

The final predelivery procedure is the overall clean-up of the unit. Make the unit LOOK like a new machine with the proper touch-up of chipped paint and a good wash job. Deliver to the customer a tractor anyone would be proud to own.

## DELIVERY SERVICE

A thorough discussion of the operation and service of this tractor at the time of delivery helps to assure complete customer satisfaction. Proper delivery should be an important phase of a dealer's program. A portion of the John Deere Delivery Receipt emphasizes the importance of proper delivery service.

Many complaints arise because the owner was not shown how to operate and service the new tractor properly. Devote enough time, at the customer's convenience, to introduce the owner to the new tractor and explain how to operate and service it.

The following procedure is recommended before the service technician and owner complete the delivery acknowledgments portion of the Delivery Receipt.

Use the operator's manual as a guide to be sure that the owner understands these points thoroughly.

1. The importance of safety.
2. The importance of lubrication and periodic services.
3. The importance of the break-in period.
4. Controls and instruments.
5. How to start and stop the engine.
6. All functions of the hydraulic system.

After explaining and demonstrating the above features, have the owner sign the Delivery Receipt and give the owner the operator's manual.

## AFTER-SALE INSPECTION

The purchaser of a new John Deere tractor is entitled to a free inspection at some mutually agreeable time within the warranty period after the equipment has been "run-in," usually after 50 to 100 hours of tractor operation. The terms of this after-sale inspection are outlined on the customer's John Deere Delivery Receipt.

The purpose of this inspection is to make sure that the customer is receiving satisfactory performance from the tractor. At the same time, the inspection should reveal whether or not the tractor is being operated, lubricated, and serviced properly.

If the recommended after-sale service inspection is followed, the dealer can eliminate a needless volume of service work by preventing minor irregularities from developing into serious problems later on. This will promote strong dealer-customer relations and present the dealer an opportunity to answer questions that may have arisen during the first few days of operation.

During the inspection service, the dealer has the further opportunity of promoting the possible sale of other new equipment.

Check operation of all controls and instruments for freedom of movement and correct operation.