

**664, 665R, 666, 666R  
Row-Crop Headers;  
630, 630A, 645, 645A  
Windrow Pickups**

**John Deere Werke Zweibrücken  
TM4530 (15APR98)**

Printed in Germany  
**ENGLISCH**

# Introduction

## FOREWORD

This manual is written for an experienced technician. Essential tools required in performing certain service work are identified in this manual and are recommended for use.

Live with safety: Read the safety messages in the introduction of this manual and the cautions presented throughout the text of the manual.



This is the safety-alert symbol. When you see this symbol on the machine or in this manual, be alert to the potential for personal injury.

Technical manuals are divided in two parts: repair and operation and tests. Repair sections tell how to repair the components. Operation and tests sections help you identify the majority of routine failures quickly.

Information is organized in groups for the various components requiring service instruction. At the beginning of each group are summary listings of all applicable essential tools, service equipment and tools, other materials needed to do the job, service parts kits, specifications, wear tolerances, and torque values.

Technical Manuals are concise guides for specific machines. They are on-the-job guides containing only the vital information needed for diagnosis, analysis, testing, and repair.

Fundamental service information is available from other sources covering basic theory of operation, fundamentals of troubleshooting, general maintenance, and basic type of failures and their causes.

## RECOGNIZE SAFETY INFORMATION

This is the safety-alert symbol. When you see this symbol on your machine or in this manual, be alert to the potential for personal injury.

Follow recommended precautions and safe operating practices.

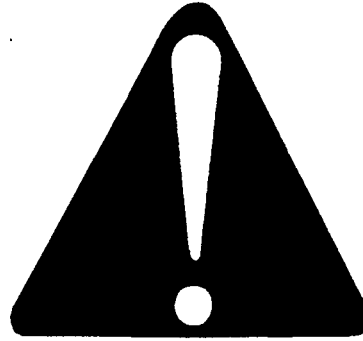

DX,ALERT -19-03MAR93

T81389 -JUN07DEC88

## FOLLOW SAFETY INSTRUCTIONS

Carefully read all safety messages in this manual and on your machine safety signs. Keep safety signs in good condition. Replace missing or damaged safety signs. Be sure new equipment components and repair parts include the current safety signs. Replacement safety signs are available from your John Deere dealer.

Learn how to operate the machine and how to use controls properly. Do not let anyone operate without instruction.

Keep your machine in proper working condition. Unauthorized modifications to the machine may impair the function and/or safety and affect machine life.

If you do not understand any part of this manual and need assistance, contact your John Deere dealer.

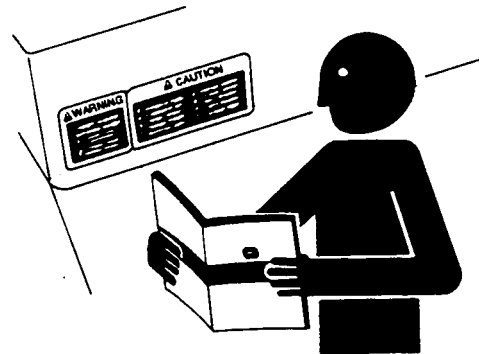

DX,READ -19-03MAR93

TS201 -JUN-23AUG88

## UNDERSTAND SIGNAL WORDS

A signal word—DANGER, WARNING, or CAUTION—is used with the safety-alert symbol. DANGER identifies the most serious hazards.

DANGER or WARNING safety signs are located near specific hazards. General precautions are listed on CAUTION safety signs. CAUTION also calls attention to safety messages in this manual.



DX,SIGNAL -19-03MAR93

TS187 -19-30SEP88

## OBSERVE ROAD TRAFFIC REGULATIONS

Always observe local road traffic regulations when using public roads.



H28930 -JUN-30JUN89

FX,ROAD -19-01MAY91

## STORE ATTACHMENTS SAFELY

Stored attachments such as dual wheels, cage wheels, and loaders can fall and cause serious injury or death.

Securely store attachments and implements to prevent falling. Keep playing children and bystanders away from storage area.



TS219 -JUN-23AUG88

DX,STORE -19-03MAR93

## PREPARE FOR EMERGENCIES

Be prepared if a fire starts.

Keep a first aid kit and fire extinguisher handy.

Keep emergency numbers for doctors, ambulance service, hospital, and fire department near your telephone.

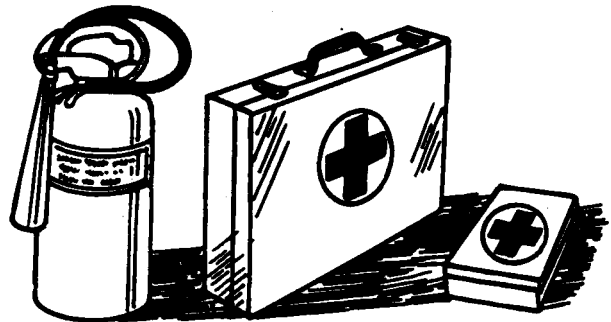

TS291 -JUN-23AUG88

DX,FIRE2 -19-03MAR93

### WEAR PROTECTIVE CLOTHING

Wear close fitting clothing and safety equipment appropriate to the job.

Prolonged exposure to loud noise can cause impairment or loss of hearing.

Wear a suitable hearing protective device such as earmuffs or earplugs to protect against objectionable or uncomfortable loud noises.

Operating equipment safely requires the full attention of the operator. Do not wear radio or music headphones while operating machine.

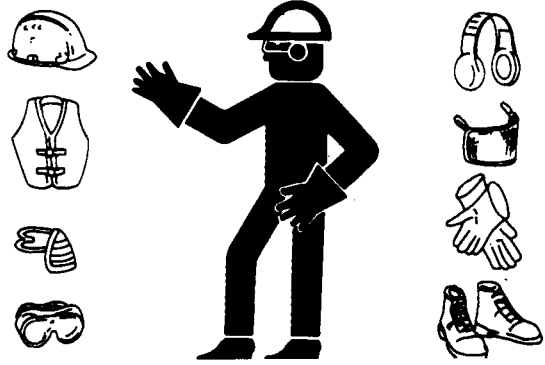

TS206 -JUN-23AUG88

DX,WEAR -19-10SEP90

### CHECK MACHINE SAFETY

Always check the road and general operating safety of the machine before using.

FX,READY -19-28FEB91

### GUARDS AND SHIELDS

Keep guards and shields in place at all times. Ensure that they are serviceable and installed correctly.

Always disengage main clutch, shut off engine and remove key before removing any guards or shields.

Keep hands, feet and clothing away from moving parts.

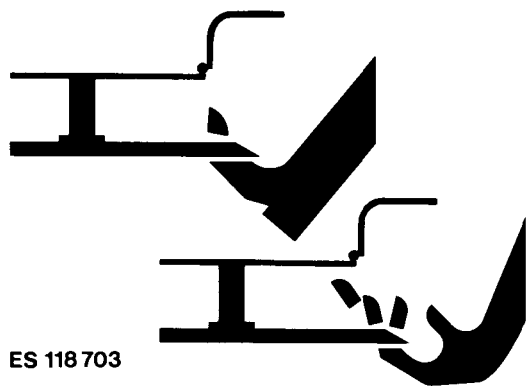

ES 118 703

FX,DEVICE -19-04DEC90

ES118703 -JUN-21MAR95

### USE SAFETY LIGHTS AND DEVICES

Prevent collisions between other road users, slow moving tractors with attachments or towed equipment, and self-propelled machines on public roads. Frequently check for traffic from the rear, especially in turns, and use hand signals or turn signal lights.

Use headlights, flashing warning lights, and turn signals day and night. Follow local regulations for equipment lighting and marking. Keep lighting and marking visible and in good working order. Replace or repair lighting and marking that has been damaged or lost. An implement safety lighting kit is available from your John Deere dealer.

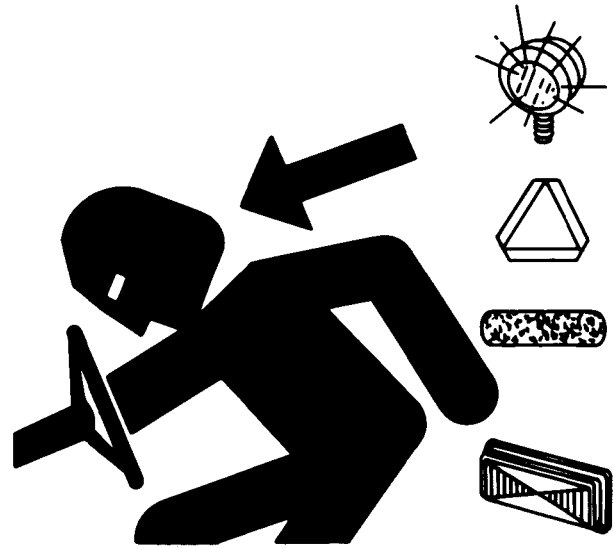

TS951 -JUN-12APR90

DX,FLASH -19-12SEP95

### KEEP HANDS AWAY FROM KNIVES

Never attempt to clear obstructions in front of or on harvesting unit unless main clutch is disengaged, engine shut off and key removed.

Everyone must be clear of the forage harvester before starting the engine.



TS254 -JUN-23AUG88

FX,KNIFE -19-21DEC90

### STAY CLEAR OF ROTATING DRIVELINES

Entanglement in rotating driveline can cause serious injury or death.

Keep tractor master shield and driveline shields in place at all times. Make sure rotating shields turn freely.

Wear close fitting clothing. Stop the engine and be sure PTO driveline is stopped before making adjustments, connections, or cleaning out PTO driven equipment.



TS1644 -JUN-22AUG95

DX,PTO -19-12SEP95

## OPERATE HARVESTING UNIT SAFELY

To avoid injury or death by being pulled into the machine:

- DO NOT attempt to feed crop into the machine or unplug feed area WHILE HARVESTING UNIT IS RUNNING. The machine feeds the material faster than you can release it.
- Disengage drive shaft and shut off harvester's engine.
- Stand clear of harvesting unit at all times when machine is operating.

ZX, TM645A010797-19-01FEB98

## PRACTICE SAFE MAINTENANCE

Understand service procedure before doing work. Keep area clean and dry.

Never lubricate, service, or adjust machine while it is moving. Keep hands, feet, and clothing from power-driven parts. Disengage all power and operate controls to relieve pressure. Lower equipment to the ground. Stop the engine. Remove the key. Allow machine to cool.

Securely support any machine elements that must be raised for service work.

Keep all parts in good condition and properly installed. Fix damage immediately. Replace worn or broken parts. Remove any buildup of grease, oil, or debris.

Disconnect battery ground cable (-) before making adjustments on electrical systems or welding on machine.



DX\_SERV -19-03MAR93

-JUN-23AUG88

TS218

## AVOID HIGH-PRESSURE FLUIDS

Escaping fluid under pressure can penetrate the skin causing serious injury.

Avoid the hazard by relieving pressure before disconnecting hydraulic or other lines. Tighten all connections before applying pressure.

Search for leaks with a piece of cardboard. Protect hands and body from high pressure fluids.

If an accident occurs, see a doctor immediately. Any fluid injected into the skin must be surgically removed within a few hours or gangrene may result. Doctors unfamiliar with this type of injury should reference a knowledgeable medical source. Such information is available from Deere & Company Medical Department in Moline, Illinois, U.S.A.

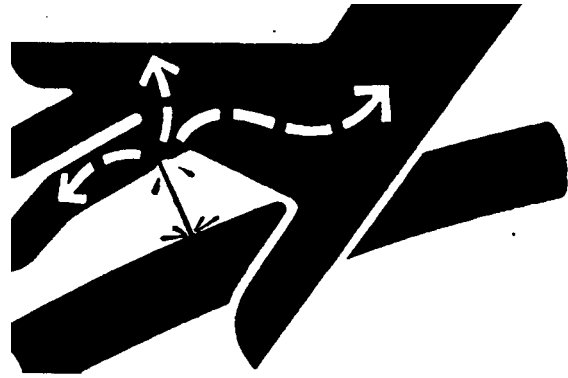

-JUN-23AUG88

X9811

DX,FLUID -19-03MAR93

## SERVICE MACHINES SAFELY

Tie long hair behind your head. Do not wear a necktie, scarf, loose clothing, or necklace when you work near machine tools or moving parts. If these items were to get caught, severe injury could result.

Remove rings and other jewelry to prevent electrical shorts and entanglement in moving parts.

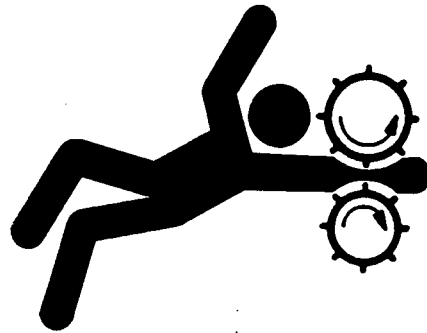

-JUN-23AUG88

TS228

DX,LOOSE -19-04JUN90



## SUPPORT MACHINE PROPERLY

Always lower the attachment or implement to the ground before you work on the machine. If you must work on a lifted machine or attachment, securely support the machine or attachment.

Do not support the machine on cinder blocks, hollow tiles, or props that may crumble under continuous load. Do not work under a machine that is supported solely by a jack. Follow recommended procedures in this manual.

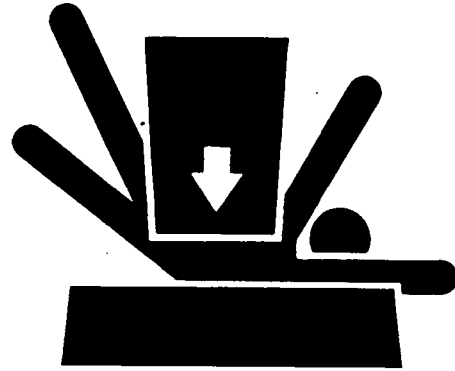

-JUN23AUG88  
TS229

DX,LOWER -19-04JUN90

## TRANSPORT WITH HARVESTING UNIT INSTALLED

Before driving forage harvester on public roads, harvesting unit must be raised and secured in this position. It must not, however, obstruct operator's view of the road. Remove crop dividers (if equipped) and install protective cover.

In case of pickup equipped with the crop deflector, always store the deflector in its transport position before driving on the road.

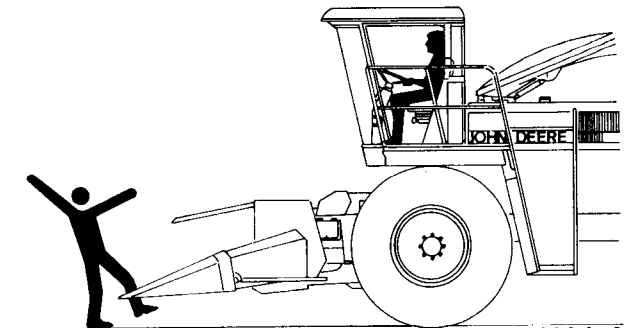

ZX 000 452

ZX, TM645A010796-19-01FEB98

-JUN03APR95  
ZX000452

## BALLASTING FOR SAFE GROUND CONTACT

Operating, steering and braking performance of forage harvester can be considerably affected by attachments which alter the center of gravity of the machine. To maintain safe ground contact, ballast the harvester at the rear end as necessary. Observe the maximum permissible axle loads and total weights.

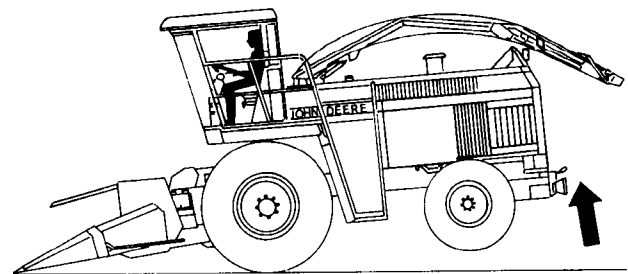

ZX 000 453

ZX, WEIGHT -19-02OCT91

-JUN03APR95  
ZX000453

## REMOVE PAINT BEFORE WELDING OR HEATING

Avoid potentially toxic fumes and dust.

Hazardous fumes can be generated when paint is heated by welding, soldering, or using a torch.

Do all work outside or in a well ventilated area. Dispose of paint and solvent properly.

Remove paint before welding or heating:

- If you sand or grind paint, avoid breathing the dust. Wear an approved respirator.
- If you use solvent or paint stripper, remove stripper with soap and water before welding. Remove solvent or paint stripper containers and other flammable material from area. Allow fumes to disperse at least 15 minutes before welding or heating.

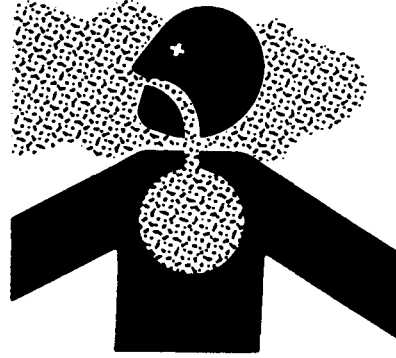

TS220 -JUN-23AUG88

DX,PAINT -19-03MAR93

## AVOID HEATING NEAR PRESSURIZED FLUID LINES

Flammable spray can be generated by heating near pressurized fluid lines, resulting in severe burns to yourself and bystanders. Do not heat by welding, soldering, or using a torch near pressurized fluid lines or other flammable materials. Pressurized lines can be accidentally cut when heat goes beyond the immediate flame area.



TSS953 -JUN-15MAY90

DX,TORCH -19-03MAR93

## DISPOSE OF WASTE PROPERLY

Improperly disposing of waste can threaten the environment and ecology. Potentially harmful waste used with John Deere equipment include such items as oil, fuel, coolant, brake fluid, filters, and batteries.

Use leakproof containers when draining fluids. Do not use food or beverage containers that may mislead someone into drinking from them.

Do not pour waste onto the ground, down a drain, or into any water source.

Air conditioning refrigerants escaping into the air can damage the Earth's atmosphere. Government regulations may require a certified air conditioning service center to recover and recycle used air conditioning refrigerants.

Inquire on the proper way to recycle or dispose of waste from your local environmental or recycling center, or from your John Deere dealer.

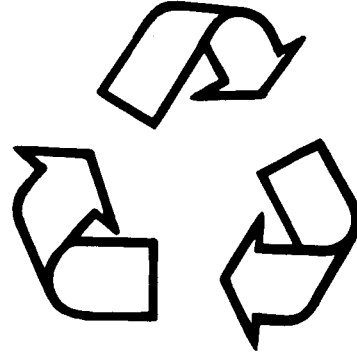

TS1133 -JUN-26NOV90

DX,DRAIN -19-03MAR93

**METRIC BOLT AND CAP SCREW TORQUE VALUES**

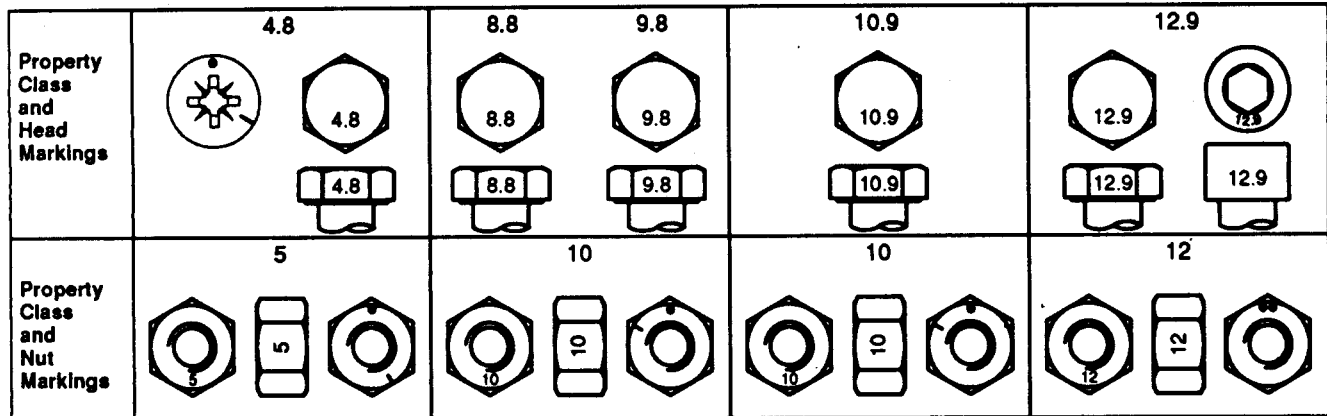

TS1163 -19-04/MAR91

Size	Class 4.8				Class 8.8 or 9.8				Class 10.9				Class 12.9			
	Lubricated <sup>a</sup>		Dry <sup>a</sup>		Lubricated <sup>a</sup>		Dry <sup>a</sup>		Lubricated <sup>a</sup>		Dry <sup>a</sup>		Lubricated <sup>a</sup>		Dry <sup>a</sup>	
	N-m	lb-ft	N-m	lb-ft	N-m	lb-ft	N-m	lb-ft	N-m	lb-ft	N-m	lb-ft	N-m	lb-ft	N-m	lb-ft
M6	4.8	3.5	6	4.5	9	6.5	11	8.5	13	9.5	17	12	15	11.5	19	14.5
M8	12	8.5	15	11	22	16	28	20	32	24	40	30	37	28	47	35
M10	23	17	29	21	43	32	55	40	63	47	80	60	75	55	95	70
M12	40	29	50	37	75	55	95	70	110	80	140	105	130	95	165	120
M14	63	47	80	60	120	88	150	110	175	130	225	165	205	150	260	190
M16	100	73	125	92	190	140	240	175	275	200	350	255	320	240	400	300
M18	135	100	175	125	260	195	330	250	375	275	475	350	440	325	560	410
M20	190	140	240	180	375	275	475	350	530	400	675	500	625	460	800	580
M22	260	190	330	250	510	375	650	475	725	540	925	675	850	625	1075	800
M24	330	250	425	310	650	475	825	600	925	675	1150	850	1075	800	1350	1000
M27	490	360	625	450	950	700	1200	875	1350	1000	1700	1250	1600	1150	2000	1500
M30	675	490	850	625	1300	950	1650	1200	1850	1350	2300	1700	2150	1600	2700	2000
M33	900	675	1150	850	1750	1300	2200	1650	2500	1850	3150	2350	2900	2150	3700	2750
M36	1150	850	1450	1075	2250	1650	2850	2100	3200	2350	4050	3000	3750	2750	4750	3500

DO NOT use these values if a different torque value or tightening procedure is given for a specific application. Torque values listed are for general use only. Check tightness of fasteners periodically.

Shear bolts are designed to fail under predetermined loads. Always replace shear bolts with identical property class.









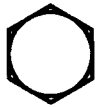

Fasteners should be replaced with the same or higher property class. If higher property class fasteners are used, these should only be tightened to the strength of the original.

<sup>a</sup> "Lubricated" means coated with a lubricant such as engine oil, or fasteners with phosphate and oil coatings. "Dry" means plain or zinc plated without any lubrication.

Make sure fasteners threads are clean and that you properly start thread engagement. This will prevent them from failing when tightening.

Tighten plastic insert or crimped steel-type lock nuts to approximately 50 percent of the dry torque shown in the chart, applied to the nut, not to the bolt head. Tighten toothed or serrated-type lock nuts to the full torque value.

**UNIFIED INCH BOLT AND CAP SCREW TORQUE VALUES**

SAE Grade and Head Markings	1 or 2 <sup>b</sup>	5	5.1	5.2	8	8.2
	NO MARK 					
SAE Grade and Nut Markings	2	5		8		
	NO MARK 					

TS1162 -19-04/MAR91

Size	Grade 1				Grade 2 <sup>b</sup>				Grade 5, 5.1, or 5.2				Grade 8 or 8.2			
	Lubricated <sup>a</sup>		Dry <sup>a</sup>		Lubricated <sup>a</sup>		Dry <sup>a</sup>		Lubricated <sup>a</sup>		Dry <sup>a</sup>		Lubricated <sup>a</sup>		Dry <sup>a</sup>	
	N·m	lb-ft	N·m	lb-ft	N·m	lb-ft	N·m	lb-ft	N·m	lb-ft	N·m	lb-ft	N·m	lb-ft	N·m	lb-ft
1/4	3.7	2.8	4.7	3.5	6	4.5	7.5	5.5	9.5	7	12	9	13.5	10	17	12.5
5/16	7.7	5.5	10	7	12	9	15	11	20	15	25	18	28	21	35	26
3/8	14	10	17	13	22	16	27	20	35	26	44	33	50	36	63	46
7/16	22	16	28	20	35	26	44	32	55	41	70	52	80	58	100	75
1/2	33	25	42	31	53	39	67	50	85	63	110	80	120	90	150	115
9/16	48	36	60	45	75	56	95	70	125	90	155	115	175	130	225	160
5/8	67	50	85	62	105	78	135	100	170	125	215	160	240	175	300	225
3/4	120	87	150	110	190	140	240	175	300	225	375	280	425	310	550	400
7/8	190	140	240	175	190	140	240	175	490	360	625	450	700	500	875	650
1	290	210	360	270	290	210	360	270	725	540	925	675	1050	750	1300	975
1-1/8	400	300	510	375	400	300	510	375	900	675	1150	850	1450	1075	1850	1350
1-1/4	570	425	725	530	570	425	725	530	1300	950	1650	1200	2050	1500	2600	1950
1-3/8	750	550	950	700	750	550	950	700	1700	1250	2150	1550	2700	2000	3400	2550
1-1/2	1000	725	1250	925	990	725	1250	930	2250	1650	2850	2100	3600	2650	4550	3350

DO NOT use these values if a different torque value or tightening procedure is given for a specific application. Torque values listed are for general use only. Check tightness of fasteners periodically.

Fasteners should be replaced with the same or higher grade. If higher grade fasteners are used, these should only be tightened to the strength of the original.

Shear bolts are designed to fail under predetermined loads. Always replace shear bolts with identical grade.

Make sure fasteners threads are clean and that you properly start thread engagement. This will prevent them from failing when tightening.

Tighten plastic insert or crimped steel-type lock nuts to approximately 50 percent of the dry torque shown in the chart, applied to the nut, not to the bolt head. Tighten toothed or serrated-type lock nuts to the full torque value.

<sup>a</sup> "Lubricated" means coated with a lubricant such as engine oil, or fasteners with phosphate and oil coatings. "Dry" means plain or zinc plated without any lubrication.

<sup>b</sup> Grade 2 applies for hex cap screws (not hex bolts) up to 152 mm (6-in.) long. Grade 1 applies for hex cap screws over 152 mm (6-in.) long, and for all other types of bolts and screws of any length.

**GREASE**

Use grease based on NLGI consistency numbers and the expected air temperature range during the service interval.

The following greases are preferred:

- John Deere HIGH TEMPERATURE EP GREASE
- John Deere MOLY HIGH TEMPERATURE EP GREASE
- John Deere GREASE-GARD™

Other greases may be used if they meet one of the following:

- NLGI Performance Classification GC-LB

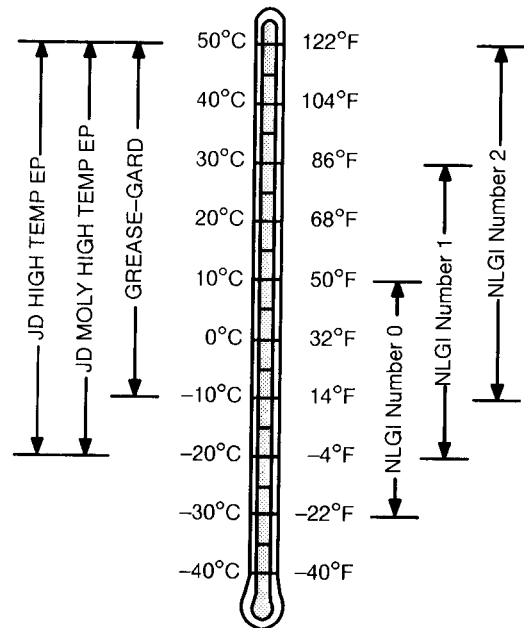

DX,GREA1 -19-18MAR96

TS1654 -JUN-14/MAR96

**GEAR OIL**

Use oil viscosity based on the expected air temperature range during the period between oil changes.

The following oils are preferred:

- John Deere EXTREME-GARD™
- John Deere GL-5 GEAR LUBRICANT

Other oils may be used if they meet the following:

- API Service Classification GL-5

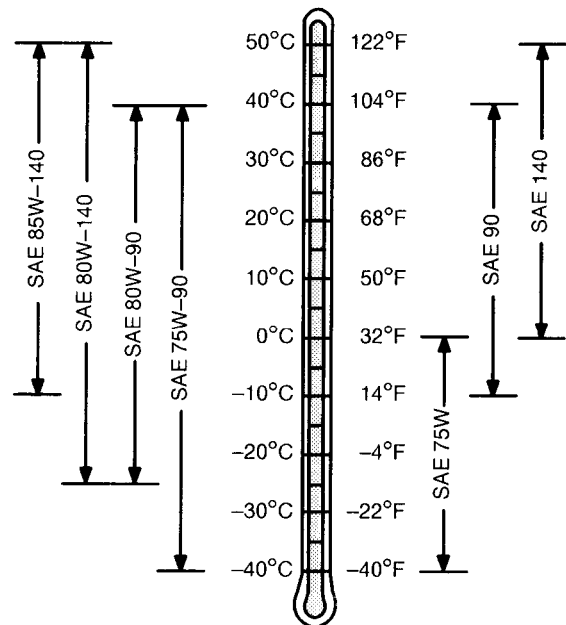

DX,GEOIL -19-18MAR96

TS1653 -JUN-14/MAR96

## SERIAL NUMBER PLATE

- A—Serial number
- B—Year of production
- C—Permissible total weight
- D—Model designation

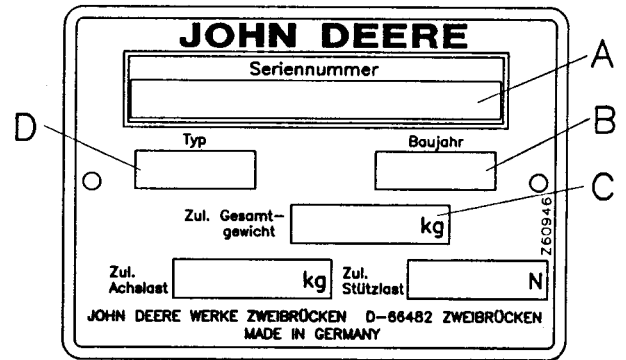

**ZX006252**

ZX, TM645A010801-19-01FEB98

-JUN-19APR95  
ZX006252

## PRODUCT IDENTIFICATION NUMBER

When ordering parts, always quote the row-crop header serial number. The serial number is on a plate at front right-hand side of the frame. Record serial number in the space provided opposite.

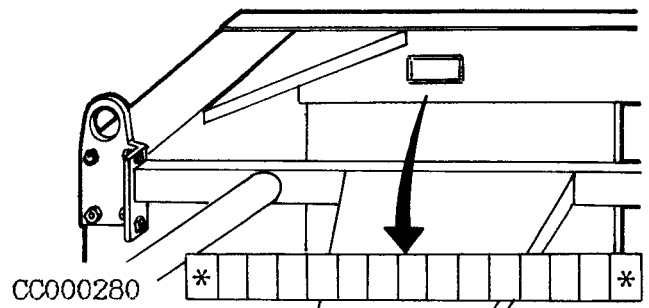

ZX, TM645A010798-19-01FEB98

-JUN-31MAR95  
CC000280

## SPECIFICATIONS FOR 664 ROW-CROP HEADER

Row spacing	711 to 813 mm (28 to 32 in.)
Gatherer chains	8 chains with automatic chain tensioner
Row-crop header drive	Gear drive
Gatherer points	Adjustable, moving freely
Cutting unit	8 cutting disks (2 per row), driven by gatherer chains
Auger	Moving freely, narrow spaced flights
Power corners	One on each side
Weight	1200 kg (2645 lb)
Width	
• Transport	3.0 m (9.8 ft)
• Operation	3.0 m (9.8 ft)
Height	1.32 m (52.1 in.)
Length	2.40 m (94.5 in.)

CC.665WRC001048-19-28JUN94



## SPECIFICATIONS FOR 665R ROW-CROP HEADER

Row spacing	914 to 965 mm (36 to 38 in.)
Gatherer chains	10 chains with automatic chain tensioner
Row-crop header drive	Gear drive
Gatherer points	Adjustable, moving freely
Cutting unit	10 cutting disks (2 per row), driven by gatherer chains
Auger	Moving freely, narrow spaced flights
Power corners	One on each side
Weight	1310 kg (2888 lb)
Width	
• Transport	3.0 m (9.8 ft)
• Operation	4.4 m (14.4 ft)
Height	1.32 m (52.1 in.)
Length	2.40 m (94.5 in.)

CC.665WRC001049-19-26APR93

**Thank you very much for  
your reading. Please Click  
Here. Then Get COMPLETE  
MANUAL. NO WAITING**



**NOTE:**

**If there is no response to  
click on the link above,  
please download the PDF  
document first and then  
click on it.**

**SPECIFICATIONS FOR 666 AND 666R  
ROW-CROP HEADERS**

Row spacing	711 to 813 mm (28 to 32 in.)
Gatherer chains	12 chains with automatic chain tensioner
Row-crop header drive	Gear drive
Gatherer points	Adjustable, free moving
Cutting unit	12 cutting disks (2 per row), driven by gatherer chains
Auger	Moving freely, narrow spaced flights
Power corners	One on each side
Weight	1600 kg (3527 lb)
Width	
• Transport	3.0 m (9.8 ft)
• Operation	4.4 m (14.4 ft)
Height	1.32 m (52.1 in.)
Length	2.40 m (94.5 in.)

ZX, TMMAIS004239-19-17JUL95

**ROTATIONAL SPEEDS ON 664 HEADER**

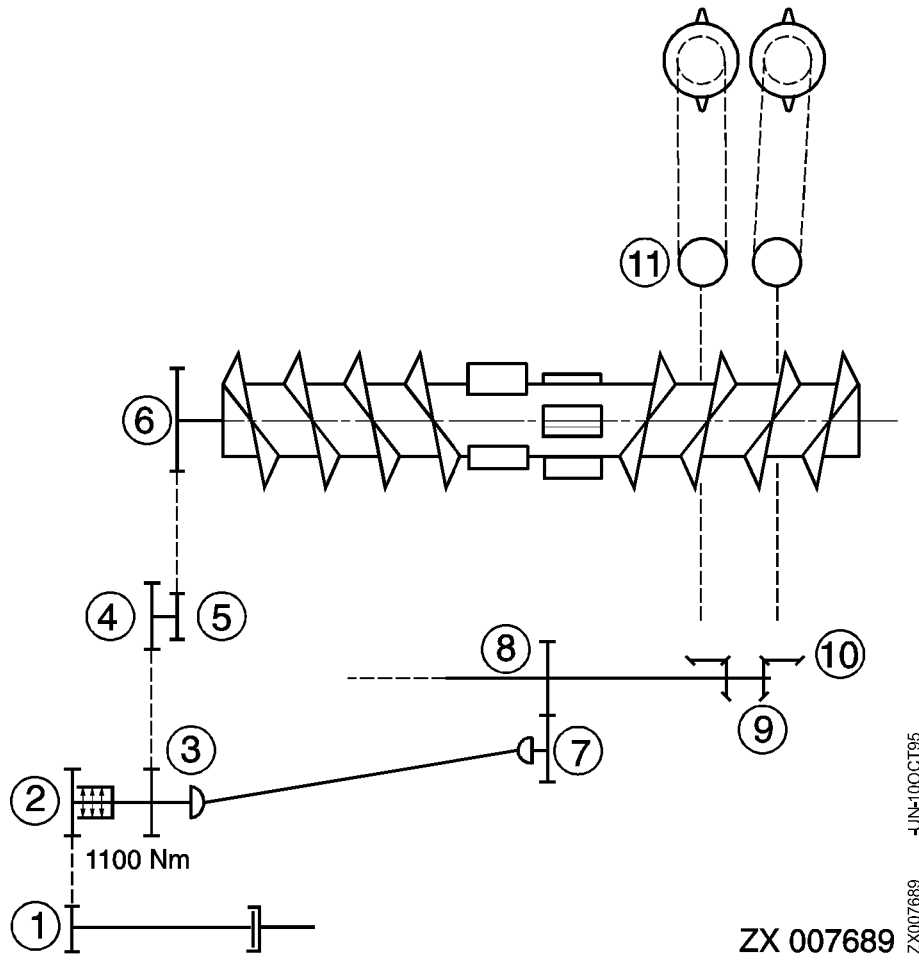

At an engine speed of 2100 rpm, the following speeds are achieved:

Number	No. of teeth	rpm			
1	16	350	401	463	530
2	22	255	292	337	386
3	15	255	292	337	386
4	15	255	292	337	386
5	13	255	292	337	386
6	37	89	101	118	134
7	22	255	292	337	386
8	24	233	267	309	353
9	10	233	267	309	353
10	10	233	267	309	353
11	9	259	297	343	392

*rpm values are given for 6000 and 6050 Series Forage Harvester.*

**ROTATIONAL SPEEDS ON 665R, 666 AND 666R HEADERS**

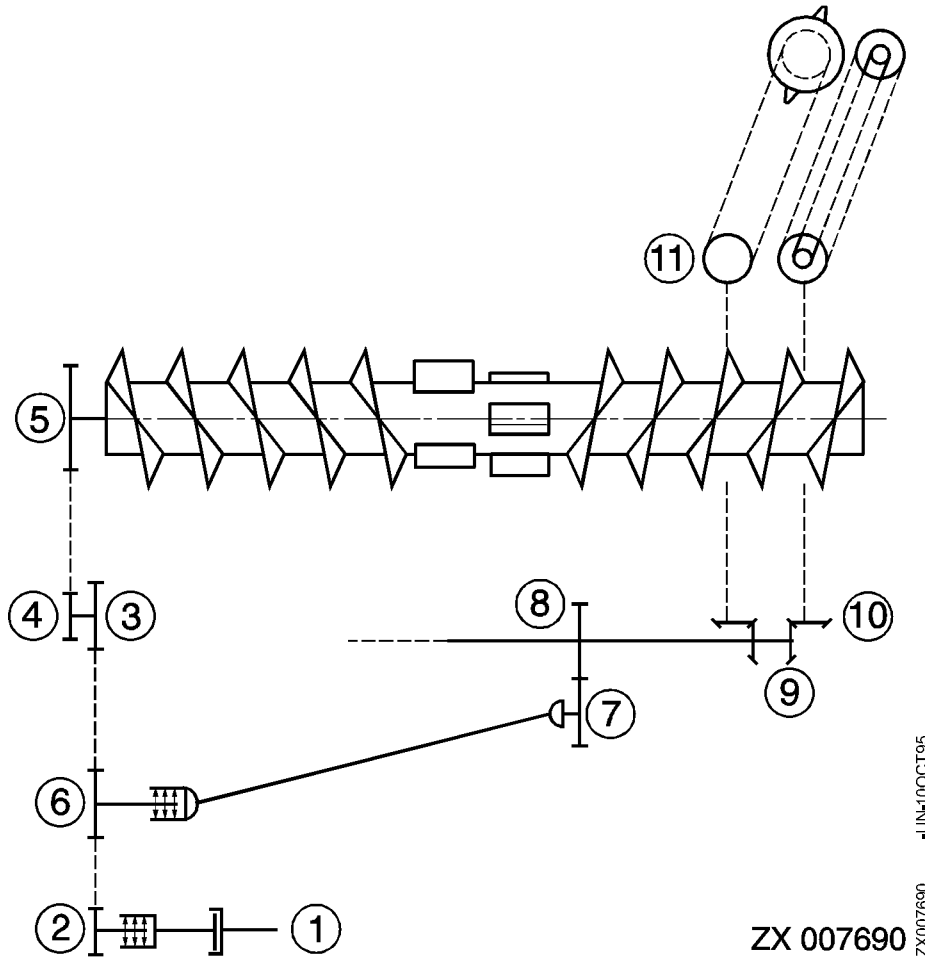

-JUN-10OCT95  
ZX007690

At an engine speed of 2100 rpm, the following speeds are achieved:

Number	No. of teeth	rpm			
1	--	350	401	463	530
2	14	350	401	463	530
3	21	233	267	309	353
4	13	233	267	309	353
5	37	82	94	108	124
6	22	223	255	295	338
7	22	223	255	295	338
8	24	204	233	270	309
9	10	204	233	270	309
10	10	204	233	270	309
11	9	227	260	300	343

*rpm values are given for 6000 and 6050 Series Forage Harvester.*