

**200
Lawn and Garden
Tractors**

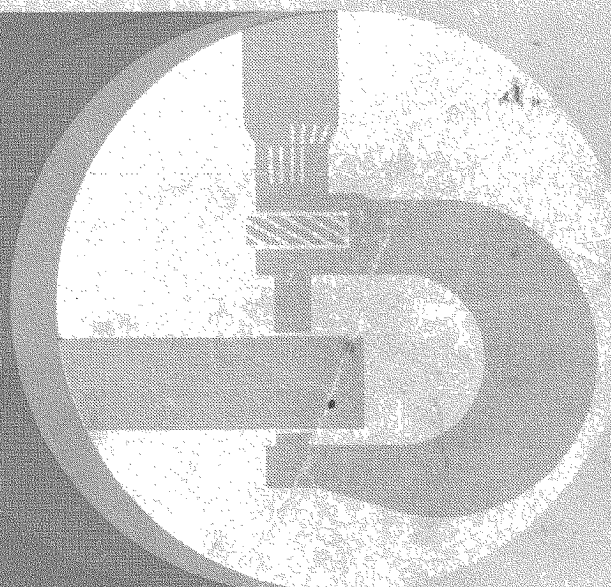

**SERVICE
MANUAL**



**John Deere Horicon Works
SM-2105 (Oct-81)**

Litho in U.S.A.

JOHN DEERE 200, 208, 210, 212, 214 AND 216 LAWN AND GARDEN TRACTORS

Service Manual
SM-2105 (June-81)

TABLE OF CONTENTS

SECTION 10 - GENERAL

- Group 5 - Tractor Identification
- Group 10 - Specifications
- Group 15 - Fuel and Lubricants
- Group 20 - Tune-Up and Adjustments

SECTION 20 - ENGINE

- Group 5 - General Information
- Group 10 - Cylinder Head, Valves and Breather
- Group 15 - Minor Engine Recondition
- Group 20 - Major Engine Recondition
- Group 25 - Specifications

SECTION 30 - FUEL SYSTEM

- Group 5 - General Information
- Group 10 - Carburetor
- Group 15 - Air Cleaner
- Group 20 - Fuel Strainer and Fuel Tank
- Group 25 - Fuel Pump
- Group 30 - Specifications

SECTION 40 - ELECTRICAL SYSTEM

- Group 5 - General Information
- Group 10 - Cranking System
- Group 15 - Ignition System
- Group 20 - Charging System
- Group 25 - Lights
- Group 30 - Electric Lift
- Group 35 - Electric PTO Clutch

SECTION 50 - POWER TRAIN

- Group 5 - General Information
- Group 10 - Clutch and Variable Speed Drive
- Group 15 - Brakes
- Group 20 - 4-Speed Transaxle
- Group 25 - PTO Clutch

SECTION 60 - HYDRAULIC LIFT SYSTEM

- Group 5 - General Information
- Group 10 - Control Valve
- Group 15 - Pump
- Group 20 - Cylinder

SECTION 70 - MISCELLANEOUS

- Group 5 - Steering Linkage
- Group 10 - Front Wheels and Axles
- Group 15 - Lift Linkage

SECTION 80 - SPECIAL SERVICE TOOLS

- Group 5 - Engine Convenience Service Tools
- Group 10 - Tractor Essential Service Tools
- Group 15 - Tractor Convenience Service Tools

SECTION 90 - TRACTOR ATTACHMENTS

- Group 5 - 37A Snow Thrower
- Group 10 - 39 and 47 Rotary Mowers
- Group 15 - 541A PTO
- Group 20 - 31 Rotary Tiller

OOA

(All information, illustrations, and specifications contained in this service manual are based on the latest information available at the time of publication. The right is reserved to make changes at any time without notice.)

Litho in U.S.A.

Copyright © 1980
DEERE & COMPANY
Moline, Illinois
All rights reserved

INTRODUCTION

This service manual contains service and maintenance information for the John Deere 200, 208, 210, 212, 214 and 216 Lawn and Garden Tractors and attachments through 1982 model (SN 195,001-).

The manual is divided into sections. Each section pertains to a certain component or operational system of the tractor or attachment. The information is divided into groups within each section.

Emphasis is placed on diagnosing malfunctions, analysis and testing. Diagnosing malfunctions includes possible troubles, their causes and how to correct them. Under specific components these troubles are analyzed to help you understand what is causing the problem. In this way, you can eliminate the cause rather than just replace the part.

Metric equivalents have been included, where applicable, throughout this service manual.

Specifications and special tools are found in the last group of each section.

Whenever new or revised pages are provided, insert them into your manual as soon as you receive them. Your service manual will always be up-to-date and be a valuable asset in your service department.



This safety alert symbol identifies important safety messages in this manual. When you see this symbol, be alert to the possibility of personal injury and carefully read the message that follows.

FOR YOUR CONVENIENCE

Vertical lines appear in the margins of many of the pages. These lines identify new material and revised information that affects specifications, procedures, and other important instructions.

WAREHOUSE LOCATION		PART NUMBER		P	QTY	DEALER BIN LOC	
10415		EM2105			1		
PICK CONTAINER	ORDER TYPE	FACTORY	PACKING LIST SEQ	PART DESCRIPTION		PICK NUMBER/LINE	
MPP	DSCG	00001		TECHNICAL MANUAL		001/0001	
DEALER NUMBER		DEALER REFERENCE		SVP ORDER NUMBER		LINE/SPLIT	
D50474		FBAL04331		D500923237		0001/00	
ORD SEQ	GRID LOC	BATCH NUMBER		WEIGHT		SHIP METHOD	
		294091 001		2.62 NR		PENSND	
FROM J. D. DISTRI SERVICE CENTER 1400 3RD AVENUE MINE IL USA 617						QUANTITY SHIPPED	
						143229	
							

GRID LOC	DEALER NUMBER	
	D50474	
PART NUMBER		QTY
EM2105		1
SVP ORDER NUMBER		PICK NUMBER/LINE
D500923237		01/0001
BATCH NUMBER		PACKING LIST SEQ
294091 001		00001

Section 10 GENERAL

Group 5 TRACTOR IDENTIFICATION

CONTENTS

	Page		Page
GROUP 5 - TRACTOR IDENTIFICATION		GROUP 20 - TUNE-UP AND ADJUSTMENTS	
Serial Numbers	5-2	Purpose of Tune-Up and Adjustments	20-1
Tractor	5-2	Visual Inspection	20-1
Engine	5-2	Engine Tune-Up	20-1
Transaxle	5-2	Tractor Adjustments	20-1
Identification Codes	5-2	Tune-Up Guide	20-1
Tire Codes	5-2	Tune-Up and Adjustments	20-2
GROUP 10 - SPECIFICATIONS		Clean Engine Shrouds and	
Engine Specifications	10-1	Cooling Fins	20-2
Battery Specifications	10-2	Clean or Replace Air Filter	
Tractor Specifications	10-2	Element	20-2
Tire Specifications	10-3	Clean Fuel Strainer	20-2
Rear Wheel Weight Bolt Size Chart	10-3	Check and Clean Engine Crankcase	
Bolt Torque Chart	10-4	Breather	20-2
Set Screw Seating Torque Chart	10-4	Check Spark Plug Gap	20-3
GROUP 15 - FUEL AND LUBRICANTS		Check Ignition Breaker Points and	
Fuel	15-1	Engine Timing	20-3
Lubricants	15-1	Adjust Carburetor	20-5
Engine Crankcase	15-1	Check Engine Speed	20-5
Transaxle	15-1	Change Engine Crankcase Oil	20-6
Tractor Grease Fittings	15-1	Check or Change Transaxle Lubricant	20-6
Hydraulic System (Optional Equip.)	15-1	Lubricate Grease Fittings	20-6
Capacities	15-1	Repack PTO Clutch Bearing	20-6
Service Intervals	15-2	Service Battery	20-6
Lubricating Grease Fittings	15-2	Check Tire Pressure	20-6
Changing Engine Crankcase Oil	15-3	Check Operation and Condition of:	
Changing Transaxle Lubricant	15-3	Lights	20-6
Repacking PTO Clutch Bearing	15-4	Lift System	20-6
Lubricating Integral Hitch Grease		Steering	20-6
Fitting	15-4	Brakes	20-6
Checking Hydraulic Lift System Fluid		Belts and Equipment	20-6
Level	15-4		

SERIAL NUMBERS

Tractor

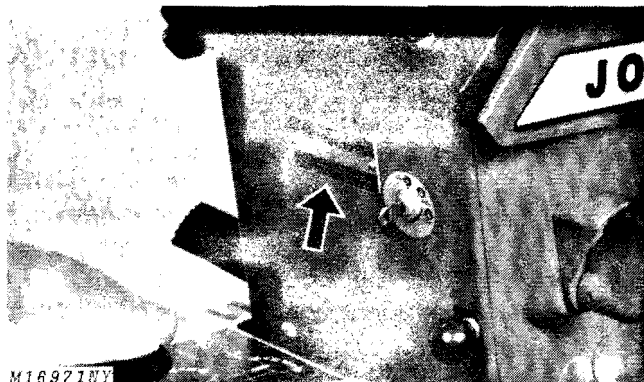
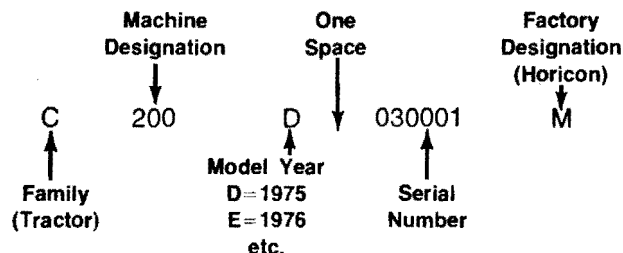

Fig. 1-Tractor Serial Number

The tractor serial number, Fig. 1, is located on the pedestal below the steering wheel.

The first letter indicates the "family of machine"; the next three numbers or letters, the "model or machine designation"; the letter in the fifth position indicates the "model year". This is followed by a space (for computer purposes), and a six-digit serial number and the letter "M" denoting Horicon as the factory of manufacture.



When ordering parts, use only the six-digit serial number. When writing about or filling out warranty claims, use all thirteen numbers, letters and spaces shown on the machine serial number plate.

Engine

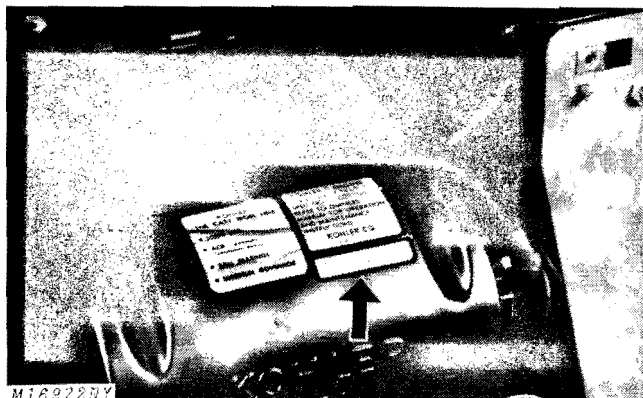

Fig. 2-Engine Serial Number

The engine serial number, Fig. 2, is located on the engine shroud.

Transaxle

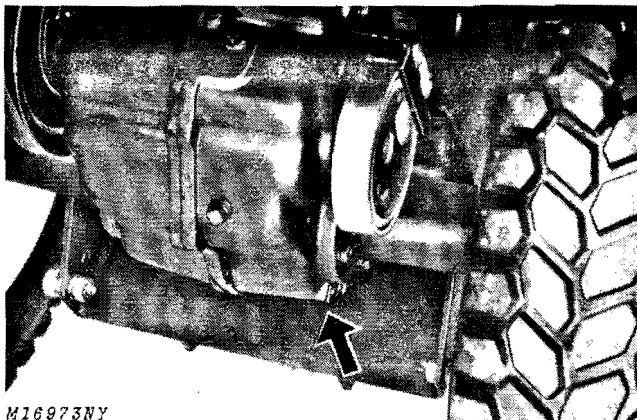

Fig. 3-Transaxle Serial Number

The transaxle serial number, Fig. 3, is located on the transaxle case next to the L.H. axle housing.

IDENTIFICATION CODES

Tire Codes

John Deere 200, 210, 212, 214 and 216 Tractors can be equipped with four different combinations of tires as follows:

Tire Code	Size Front	Size Rear	Tread
GT-3	16x6.50-8	23x8.50-12	High-Flotation
GT-4	4.80/4.00-8 -----	----- 23x8.50-12	Studded Traction
GT-5	16x6.50-8	23x10.50-12	High-Flotation
GT-8 Bar Tread	16x6.50-8 or 4.80/4.00-8 -----	----- 23x10.50-12	High-Flotation Traction

NOTE: The 200 Tractor is equipped with GT-3 tires as standard equipment. The 208 Tractor is equipped with 4.80 x 4.00-8 (2-ply) front tires and 23 x 8.50-12 rear tires as standard equipment. The 208 Tractor can be equipped with GT-3, GT-4, GT-5, or GT-8 tires listed above if desired. The 210, 212, 214 and 216 Tractors are equipped with GT-5 tires as standard equipment.

Group 10 SPECIFICATIONS

ENGINE SPECIFICATIONS

Item	200	208	210
Engine Model No.	K181QS	K181S	K241AQS
Manufacturer	Kohler	Kohler	Kohler
Cylinders	One	One	One
Stroke/Cycle	Four	Four	Four
Bore	2.94 in. (74.6 mm)	2.94 in. (74.6 mm)	3.25 in. (82.5 mm)
Stroke	2.75 in. (69.8 mm)	2.75 in. (69.8 mm)	2.88 in. (73.1 mm)
Displacement	18.6 cu. in.	18.6 cu. in.	23.9 cu. in.
Speeds (Fast) No Load ..	3400 to 3500 rpm	3400 to 3500 rpm	3400 to 3500 rpm
Speeds (Idle)	1700 to 1900 rpm	1700 to 1900 rpm	1700 to 1900 rpm
Horsepower*	8	8	10
Normal Compression	110 to 120 psi	110 to 120 psi	110 to 120 psi
Valve Clearance			
Intake (Cold)	0.007 in. (0.178 mm)	0.007 in. (0.178 mm)	0.010 in. (0.254 mm)
Exhaust (Cold)	0.016 in. (0.406 mm)	0.016 in. (0.406 mm)	0.020 in. (0.508 mm)
Ignition	Battery	Battery	Battery
Spark Plug**	Champion-J-8 or XJ8 AC-45-M or R-46 Prestolite-14-7 or 14-R8	Champion-RJ8	Champion-H-10 AC-45L Prestolite-14-L7B
Spark Plug Gap	0.025 in. (0.635 mm)	0.025 in. (0.635 mm)	0.035 in. (0.889 mm)
Breaker Point Gap	0.020 in. (0.508 mm)	0.020 in. (0.508 mm)	0.020 in. (0.508 mm)
Charging System	Alternator	Alternator	Alternator
Starter	12-Volt	12-Volt	12-Volt
Air Filter	Dry-type	Dry-type	Dry-type

Item	212	214	216
Engine Model No.	K301AQS	K321AQS	K341AQS
Manufacturer	Kohler	Kohler	Kohler
Cylinders	One	One	One
Stroke/Cycle	Four	Four	Four
Bore	3.38 in. (85.8 mm)	3.50 in. (88.9 mm)	3.75 in. (95.2 mm)
Stroke	3.25 in. (82.5 mm)	3.25 in. (82.5 mm)	3.25 in. (82.5 mm)
Displacement	29.1 cu. in.	31.3 cu. in.	35.9 cu. in.
Speeds (Fast) No Load ..	3400 to 3500 rpm	3400 to 3500 rpm	3400 to 3500 rpm
Speeds (Idle)	1700 to 1900 rpm	1700 to 1900 rpm	1700 to 1900 rpm
Horsepower*	12	14	16
Normal Compression	110 to 120 psi	110 to 120 psi	110 to 120 psi
Valve Clearance			
Intake (Cold)	0.010 in. (0.254 mm)	0.010 in. (0.254 mm)	0.010 in. (0.254 mm)
Exhaust (Cold)	0.020 in. (0.508 mm)	0.020 in. (0.508 mm)	0.020 in. (0.508 mm)
Ignition	Battery	Battery	Battery
Spark Plug**	Champion-H-10 AC-45L Prestolite-14-L7B	Champion-H-10 AC-45L Prestolite-14-L7B	Champion-H-10 AC-45L Prestolite-14-L7B
Spark Plug Gap	0.035 in. (0.889 mm)	0.035 in. (0.889 mm)	0.035 in. (0.889 mm)
Breaker Point Gap	0.020 in. (0.508 mm)	0.020 in. (0.508 mm)	0.020 in. (0.508 mm)
Charging System	Alternator	Alternator	Alternator
Starter	12-Volt	12-Volt	12-Volt
Air Filter	Dry-type	Dry-type	Dry-type

*The horsepower rating shown is established by the engine manufacturer in accordance with Standard Internal Combustion Engine Institute procedure. It is corrected at 60°F. and 29.22 in. Hg. Barometer and is developed from laboratory test engines equipped with standard air cleaner and muffler.

**In Canada, compliance with radio interference regulations certified. Replace spark plug with resistor-type spark plug only. Use Champion RJ8 for 200 and 208 Tractors. Use Champion RH10 for 210, 212, 214 and 216 Tractors.

BATTERY SPECIFICATIONS

Tractor	Battery
200, 208	John Deere, 12 Volt, (AM30094), BCI Group U1, 135 cold cranking amps at 0°F (-17°C), 30-minute reserve capacity.
210, 212, 214, 216	John Deere, 12 Volt, (AM31186), BCI Group 22F, 255 cold cranking amps at 0°F (-17°C), 55-minute reserve capacity.

TRACTOR SPECIFICATIONS

Item	200, 208	210, 212, 214, 216
CAPACITIES		
Fuel Tank	3-1/2 U.S. Gallons (13.25 L)	3-1/2 U.S. Gallons (13.25 L)
Crankcase	2-1/2 U.S. Pints (1.18 L)	** (S.N. 30001-95261) 3 U.S. Pts. (1.42 L) *** (S.N. 95262 and up) 4 U.S. Pints (1.89 L)
Transaxle	3-1/2 U.S. Pints (1.65 L)	3-1/2 U.S. Pints (1.65 L)
Hydraulic System (optional)		2 U.S. Pints (0.94 L)
TRANSMISSION		
Type	Transaxle	Transaxle
Gear Selections	4 forward - 1 reverse	4 forward - 1 reverse
TRAVEL SPEEDS - (at 3400 rpm)		
1st Gear (Variable)	0.3 to 0.9 mph (.6 to 1.6 kms/hr)	0.3 to 0.9 mph (.6 to 1.6 kms/hr)
2nd Gear (Variable)	1.0 to 2.7 mph (2.1 to 4.6 kms/hr)	1.0 to 2.7 mph (2.1 to 4.6 kms/hr)
3rd Gear (Variable)	1.8 to 4.7 mph (3.8 to 8.0 kms/hr)	1.8 to 4.7 mph (3.8 to 8.0 kms/hr)
4th Gear (Variable)	2.6 to 7.0 mph (5.5 to 11.9 kms/hr)	2.6 to 7.0 mph (5.5 to 11.9 kms/hr)
Reverse (Variable)	1.4 to 3.7 mph (2.4 to 5.3 kms/hr)	1.4 to 3.7 mph (2.4 to 5.3 kms/hr)
DIMENSIONS		
Wheelbase	46 in. (1.168 m)	46 in. (1.168 m)
Overall Length	67-1/2 in. (1.715 m)	67-1/2 in. (1.715 m)
Overall Height	42 in. (1.067 m)	42 in. (1.067 m)
Overall Width (maximum)	41-1/2 in. (10.54 m)	41-1/2 in. (10.54 m)
WHEEL TREAD		
Front	31 in. (78.74 cm)	31 in. (78.74 cm)
Rear (GT-3 Tires)	27 in. or 33 in. (68.58 cm or 83.82 cm)	27 in. or 33 in. (68.58 cm or 83.82 cm)
(GT-5 Tires)	28-1/2 in. or 31 in. (72.39 cm or 78.74 cm)	28-1/2 in. or 31 in. (72.39 cm or 78.74 cm)
BRAKES		
Type	Band, pedal-operated	Band, pedal-operated
Parking	Hand-lock foot brake	Hand-lock foot brake
CLUTCH		
PTO CLUTCH	V-belt system	V-belt system
STEERING		
LIFT*	Manual	Manual
SHIPPING WEIGHT	Enclosed gear	Enclosed gear
	Manual, Electric	Manual, Electric, Hydraulic
	200 Tractor - 691 lbs. (313 kg)	759 lbs. (344 kg)
	208 Tractor - 673 lbs. (305 kg)	

*Electric and Hydraulic Lifts are dealer installed options.

**Aluminum Pan

***Steel Pan

TIRE SPECIFICATIONS

Tire Code	Location	Size	Tubeless	Ply-Rating	Tread	Tire Inflation Pressure
***	Front	4.80x4.00-8	Yes	2	Studded High- Flotation	10 to 12 psi (69 to 82 kPa)
	Rear	23x8.50-12	Yes	2		5 to 10 psi (34 to 69 kPa)
GT-3	Front	16x6.50-8	Yes*	2	High- Flotation	6 to 16 psi (41 to 110 kPa)
	Rear	23x8.50-12	Yes*	2		5 to 10 psi (34 to 69 kPa)
GT-4	Front	4.80/4.00-8	No	4	Studded Traction	12 to 40 psi (82 to 276 kPa)
	Rear	23x8.50-12	Yes*	2		5 to 10 psi (34 to 69 kPa)
GT-5****	Front	16x6.50-8	Yes*	2	High- Flotation	6 to 16 psi (41 to 110 kPa)
	Rear	23x10.50-12	Yes*	2		5 to 10 psi (34 to 69 kPa)
GT-8 Bar Tread	Front**	16x6.50-8	Yes*	2	High- Flotation Traction	6 to 16 psi (41 to 110 kPa)
	Rear	23x10.5-12	Yes*	2		5 to 10 psi (34 to 69 kPa)

*Tubes Available for service. See your parts catalog.

**Use 4.80/4.00-8 (4-ply) front tires with front-end loaders.

***Regular equipment tires on 208 Tractor.

****Regular equipment tires on 210, 212, 214 and 216 Tractors.

REAR WHEEL WEIGHT BOLT SIZE CHART

Tire/Wheel Option	Wheel Position	No. of Weights	Bolt Size
GT-3 or GT-4	Narrow	1	1/2 x 5-1/2
GT-3 or GT-4	Narrow	2	1/2x7-1/2
GT-3 or GT-4	Wide	1	1/2x5-1/2
GT-3 or GT-4	Wide	2	1/2x7-1/2
GT-5	Narrow	1	1/2x5-1/2
GT-5	Narrow	2	1/2x8
GT-5	Wide	1	1/2x5-1/2
GT-5 or GT-8	Wide	2	1/2x7-1/2

BOLT TORQUE CHART

AVERAGE TIGHTENING TORQUE FOR BOLTS
(BASED ON 85% OF YIELD)

Bolt Size	A17B			A17D			A17F		
	in-lb	ft-lb	Nm	in-lb	ft-lb	Nm	in-lb	ft-lb	Nm
1/4	72	6	8	120	10	13.5	168	14	19
5/16	156	13	17.6	240	20	27	360	30	40.7
3/8	276	23	31.2	420	35	47.5	600	50	67.8
7/16	420	35	47.5	660	55	74.6	960	80	108.5
1/2	660	55	74.6	1020	85	115.2	1440	120	162.7
9/16	900	75	101.7	1560	130	176.3	2100	175	237.3
5/8	1260	105	142.4	2040	170	230.5	2880	240	325.4
3/4	2220	185	250.8	3600	300	406.7	5100	425	576.2
7/8	1920	160	216.9	5340	445	603.3	8220	685	928.7
1	3000	250	339	8040	670	908.4	12360	1030	1396.5
1-1/8	3960	330	447.4	10920	910	1233.8	17520	1460	1979.5
1-1/4	5760	480	650.8	15000	1250	1694.8	24720	2060	2793

B-grade bolts larger than 3/4-inch are sometimes formed hot rather than cold, which accounts for the lower mean tightening torque.

SET SCREW SEATING TORQUE CHART

Screw Size	Seating Torque	
	in-lb	Nm
#5	9	1.0
#6	9	1.0
#8	20	2.3
#10	33	3.7
1/4	87	9.8
5/16	165	18.6
3/8	290	32.8
7/16	430	48.6
1/2	620	70.1
9/16	620	70.1
5/8	1225	138.4
3/4	2125	240.1

Group 15 FUEL AND LUBRICANTS

FUEL

Always use fresh, clean "regular grade or non-leaded" gasoline having an octane rating of 87 or higher. We recommend non-leaded gasoline because it reduces cylinder head deposits.

The use of GASOHOL is not recommended.

Do not use gasohol, premium, ethyl or white gasoline. Never use special additives such as carburetor cleaners, de-icers, or moisture-removing liquids in your gasoline.

IMPORTANT: Do not mix oil with gasoline. Do not permit dirt or other foreign matter to enter the fuel system. This could cause hard starting, poor performance and engine damage. Always use clean gasoline storage cans and funnels.

LUBRICANTS

Engine Crankcase

IMPORTANT: During the first 5 hours of break-in operation on a new engine or whenever the engine is overhauled or rebuilt with a new short block, use a good quality single viscosity oil with a service designation no higher than "SB" or "SC". DO NOT use "SD" or "SE" service designation oils during break-in operation. If "SB" or "SC" oils are not available, any single viscosity oil may be used. After the first 5 hours of break-in operation, drain the engine crankcase and refill with fresh oil with a service designation shown below.

John Deere TORQ-GARD SUPREME™ engine oil is recommended. If other oils are used, they must be premium quality engine oils meeting performance requirements of:

- API Service Classification
CD/SD
- Military Specification
MIL-L-2104C

For low temperature operation, where oils meeting the above requirements may not be available in appropriate viscosity grade, oils meeting the performance requirements of API Service Classification CS/SC or Military Specification MIL-L46152 may be used, but at a shorter drain interval.

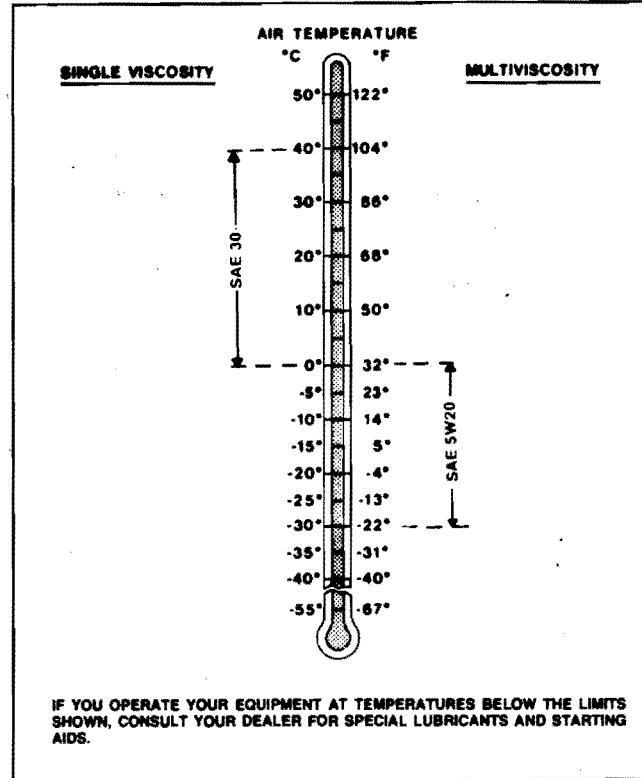

M27560

Quality engine oils are blended, so additives are neither required nor recommended.

CAPACITIES

Fuel Tank	3-1/2 U.S. gallons (13.5 L)
Crankcase:	
200, 208	2 U.S. pints (0.946 L)
210, 212, 214 and 216	Aluminum Pan Engine 3 U.S. pints (1.42 L) Steel Pan Engine 4 U.S. pints (1.89 L)
Transaxle	3-1/2 U.S. pints (1.65 L)
Hydraulic System (optional equip.)	2 U.S. pints (0.94 L)

Grease Fittings

John Deere High Temperature/Extreme Pressure Grease is recommended for axle bearings and front axle pivots. If other greases are used, use SAE Multipurpose High Temperature Grease with Extreme Pressure (EP) performance capable of operating at compartment temperatures above 150°C.

John Deere Multipurpose Grease is recommended for all grease fittings. If other greases are used, use:

- SAE Multipurpose Grease
- SAE Multipurpose Grease containing 3 to 5 percent molybdenum disulfide.

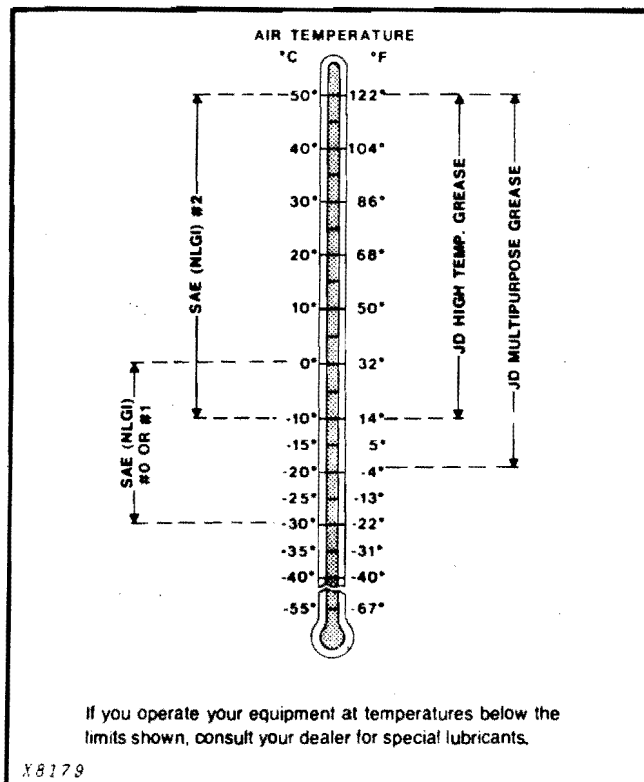

Alternative Lubricants

Conditions in certain geographical areas outside the United States and Canada may require different lubricant recommendations than those printed in the operator's manual. Consult your John Deere dealer to obtain alternative lubricant recommendations.

Transaxle

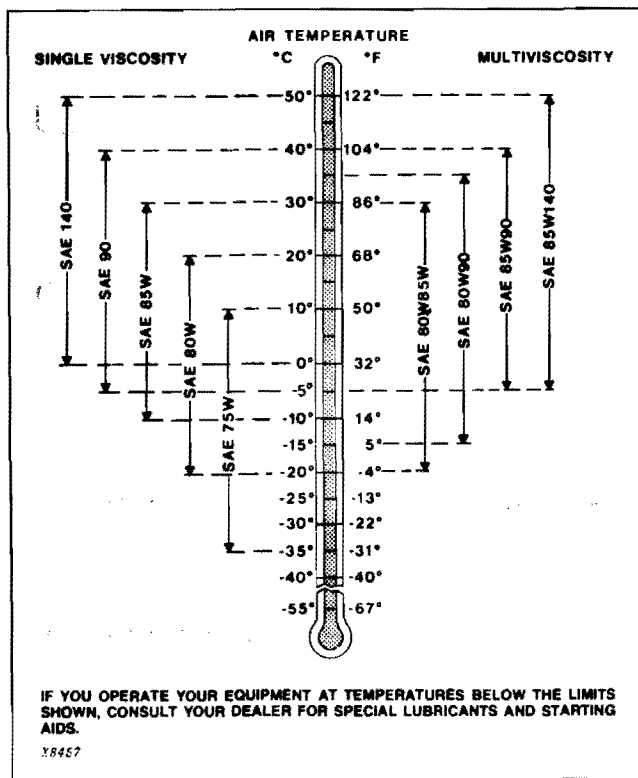

Use John Deere SCL Gear Oil or oils meeting performance requirements of API Service Classification GL-4 and containing sulfur, chlorine and lead additives.

Depending on air temperature range during the fill period, use oil viscosity as shown.

**Hydraulic Lift System
(Extra Equipment)**

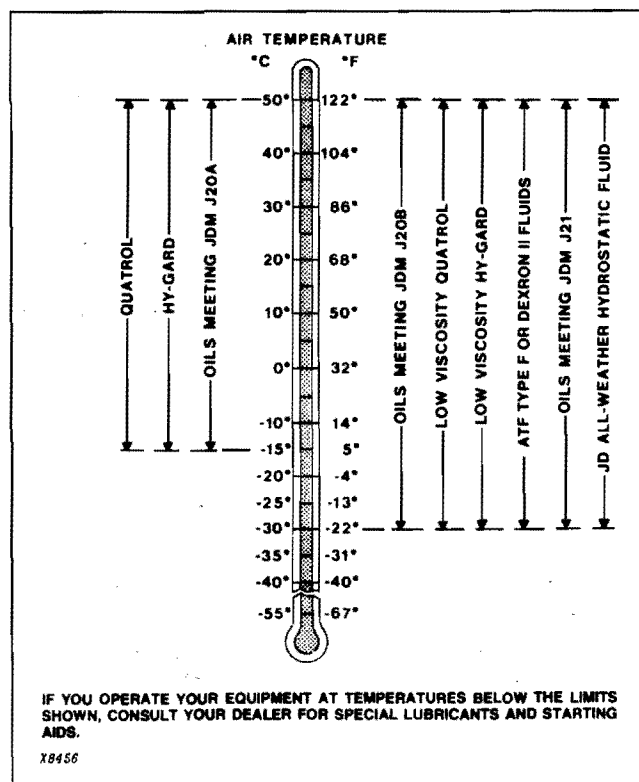

Use John Deere All-Weather Hydrostatic Fluid, John Deere Hy-Gard® Transmission and Hydraulic Oil or one of the following oils meeting John Deere Standard JDM21.

- Type F or Dexron II Automatic Transmission and Hydraulic Oil
- Quatrol® Oils
- Oils meeting the requirements of John Deere Standard JDM J20

SERVICE INTERVALS

Lubricating Grease Fittings

Grease tractor grease fittings in Spring and Fall Season. Tractor grease fitting locations are as follows:

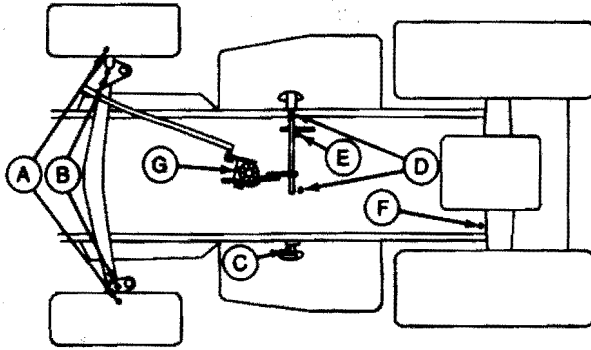

M14459B

- A—Front Wheel Hubs
- B—Front Axle Spindles
- C—Brake Pedal Shaft
- D—Clutch Pedal Shaft
- E—Primary Lift Shaft
- F—Rear Brake Shaft
- G—Steering Gear*

Fig. 1-Grease Fitting Locations (Serial No. 30,001-55,000)

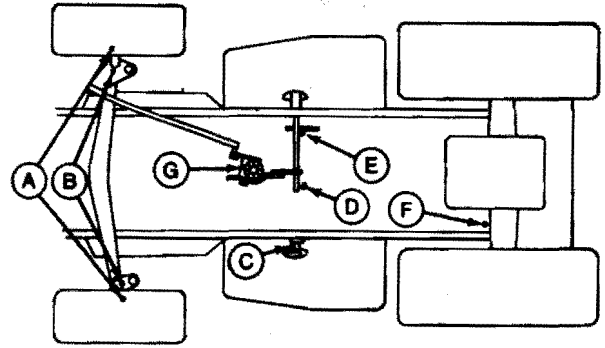

M14460N

- A—Front Wheel Hubs
- B—Front Axle Spindles
- C—Brake Pedal Shaft
- D—Clutch Pedal Shaft
- E—Primary Lift Shaft
- F—Rear Brake Shaft
- G—Steering Gear*

Fig. 2-Grease Fitting Locations (Serial No. 55,001-95,001)

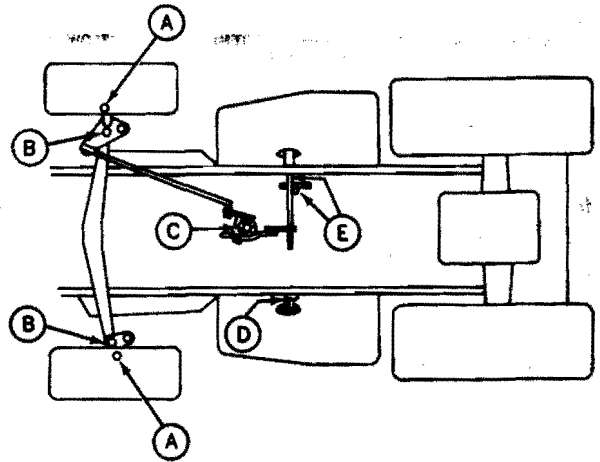

M23340

- A—Front Wheel Hubs
- B—Front Axle Spindles
- C—Steering Gear (See "IMPORTANT" below)
- D—Brake Pedal Shaft
- E—Primary Lift Shaft (2)

Fig. 3-Grease Fitting Locations (Serial No. 95,001-)

IMPORTANT: Do not overlubricate steering column fitting. Only 3 to 4 strokes with a hand grease gun are necessary. Do not use a high-pressure grease gun on this fitting.

LUBRICATING GREASE FITTINGS—Continued

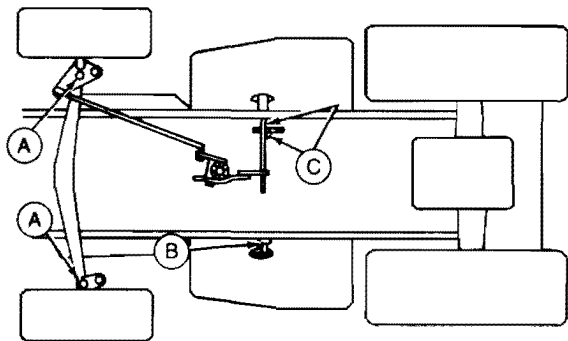

M28401

- A—Front Axle Spindles
- B—Brake Pedal Shaft
- C—Primary Lift Shaft

Fig. 4-Grease Fitting Locations
(Serial No. 109,001-)

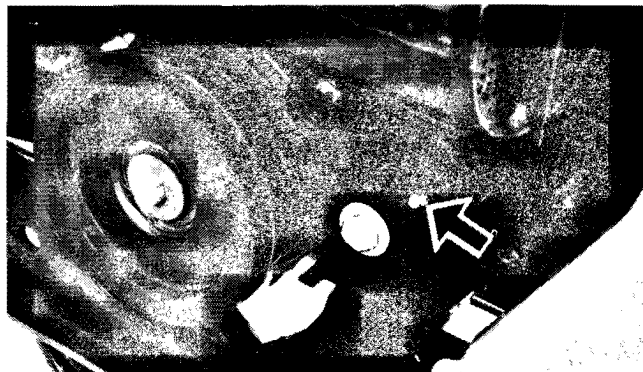

M28544

Fig. 5-Hanger Spacer Fitting on 200 Series
Tractors (Serial No. 190,001-)

Group 20

TUNE-UP AND ADJUSTMENTS

PURPOSE OF TUNE-UP AND ADJUSTMENTS

Generally, the customer complaint will reveal which system or component requires checking. However, when dealing with the entire tractor, it is recommended that the step-by-step procedures outlined on the following pages be used.

VISUAL INSPECTION

Much can be learned about the general condition of the tractor by a thorough visual inspection. For convenience, remove the side panels and hood.

Check the engine, transaxle and hydraulic system (if so equipped) for evidence of oil leakage.

Inspect battery for excessive corrosion, cracked case, proper installation and cable connections. Note general condition of wiring harness. Be sure the harness is not oil-soaked and that it is not frayed or damaged.

ENGINE TUNE-UP

Engine tune-up is making minor repairs and adjustments in an orderly sequence to improve the overall efficiency and operation of the engine.

Tune-up includes checking, adjusting and servicing the electrical, ignition, air intake, fuel and lubrication systems.

TRACTOR ADJUSTMENTS

Adjusting tractor components insures that engine horsepower will be utilized in the most efficient manner.

Adjustments to be made on the tractor include: Checking or changing transaxle lubricant, lubricating grease fittings, checking PTO clutch and brake, tractor brakes, belts and equipment.

TUNE-UP GUIDE

The following guide offers an orderly sequence for servicing a tractor that has been running well.

Also use this guide to explain to your customers what a tune-up includes. Be sure to obtain customer permission before performing these services.

1. Clean Engine Shrouds and Cooling Fins
2. Clean or Replace Air Filter Element
3. Clean Fuel Strainer
4. Check and Clean Engine Crankcase Breather
5. Check Spark Plug Gap
6. Check Ignition Breaker Points and Engine Timing
7. Adjust Carburetor
8. Check Engine Speed
9. Change Engine Crankcase Oil
10. Check or Change Transaxle Lubricant
11. Lubricate Grease Fittings
12. Repack PTO Clutch Bearing
13. Service Battery
14. Check Tire Pressure
15. Check Operation and Condition of:
 - (A) Lights
 - (B) Lift System
 - (C) Steering
 - (D) Brakes (PTO Clutch and Tractor)
 - (E) Belts and Equipment

TUNE-UP AND ADJUSTMENTS

1. Clean Engine Shrouds and Cooling Fins

Fig. 1-Engine Shrouds
(210 Tractor Illustrated)

Remove engine shrouds, Fig. 1. Blow out cooling fins with compressed air. Be sure all dirt and debris are removed from the engine.

2. Clean or Replace Air Filter Element

Fig. 2-Air Filter Element
(210 Tractor Illustrated)

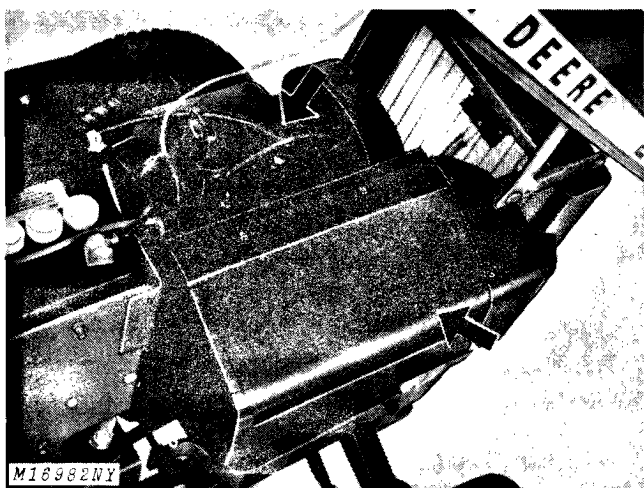
Remove the air filter element, Fig. 2. Tap the filter lightly against a flat surface and brush out dust. Do not clean filter with a liquid cleaner or compressed air.

Replace filter if it is bent, crushed, damaged or extremely dirty.

3. Clean Fuel Strainer

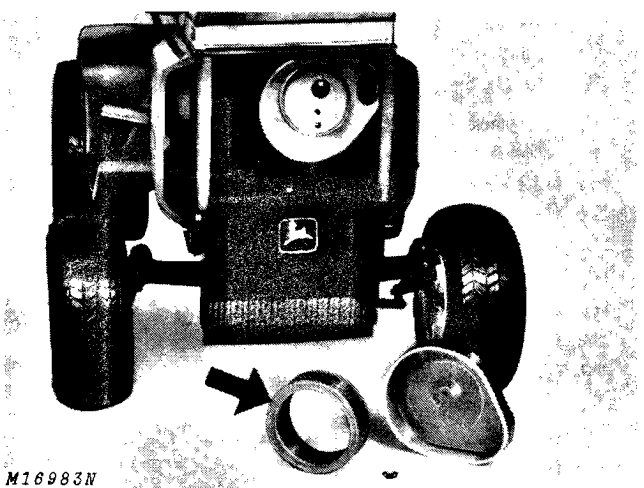
Fig. 3-Fuel Shut-Off Valve

Close the fuel shut-off valve, under fuel tank, Fig. 3. Disconnect hose from valve. Attach a 12-inch length of 1/4-inch hose and drain fuel tank into a clean container.

Remove hose from valve. Unscrew shut-off valve with strainer from fuel tank. Thoroughly clean all particles from strainer.

Install shut-off valve and strainer assembly. Close the valve, connect the hose, and fill fuel tank.

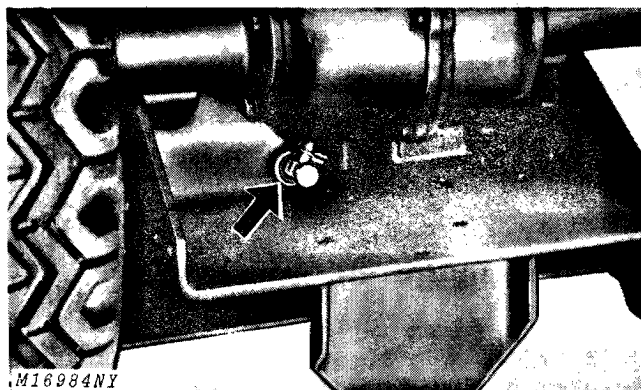
4. Check and Clean Engine Crankcase Breather

A clogged crankcase breather can cause positive pressure to build up in the crankcase.

Check crankcase vacuum with a U-tube water manometer.

An engine in good condition and operating at normal temperatures will show a 5 to 10-inch water column on the manometer.

An engine in good condition and operating at normal engine temperatures will show a 5 to 10-inch water column of vacuum or negative pressure on the manometer, (see Fig. 4).

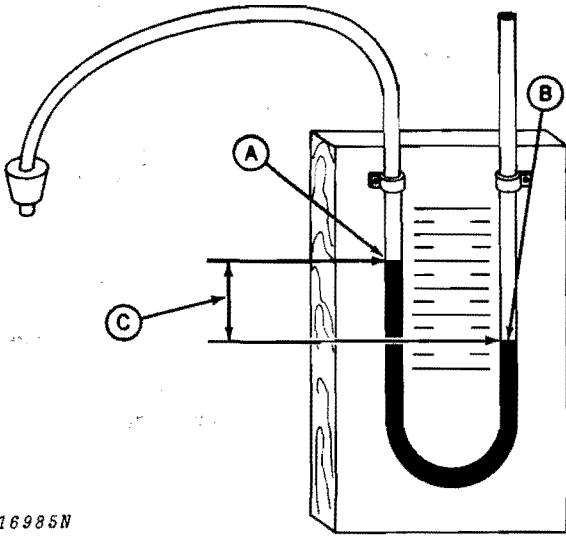

M16985N

A—Negative Pressure B—Positive Pressure
C—Difference Between Columns

Fig. 4-U-Tube Water Manometer

When using manometer, Fig. 4, place stopper into oil fill hole (other end open to atmosphere) and measure difference between columns (C).

If water column is higher in tube connected to engine, vacuum or negative pressure (A) is indicated. If the higher column is on the atmospheric side of manometer, positive pressure (B) is present.

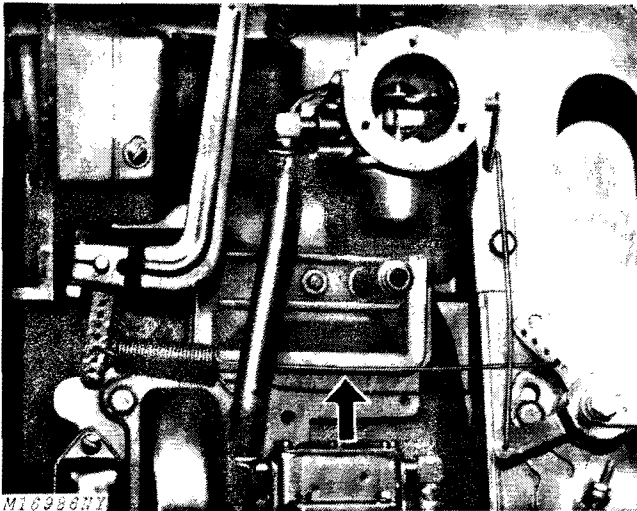

M10986NY

Fig. 5-Engine Crankcase Breather
(210 Tractor Illustrated)

Disassemble breather assembly, Fig. 5, and clean it thoroughly. Reinstall breather assembly and recheck pressure.

5. Check Spark Plug Gap

Remove spark plug, check condition and reset gap, page 10-10-1.

Good operating conditions are indicated if plug has light gray or tan appearance. A dead white appearance could indicate overheating. A black (carbon) appearance may indicate an "over-rich" fuel mixture, clogged air cleaner or improper carburetor adjustment.

Do not service a plug in poor condition. Install a new plug and torque it to 18 to 22 ft-lbs (24 to 30 Nm). See page 10-10-1.

6. Check Ignition Breaker Points and Engine Timing

Replace badly burned or pitted breaker points. If points are oxidized, rub a piece of coarse cloth across the surfaces. Clean dirty or oily points with a cloth, but make sure no particles of lint are left between the surfaces.

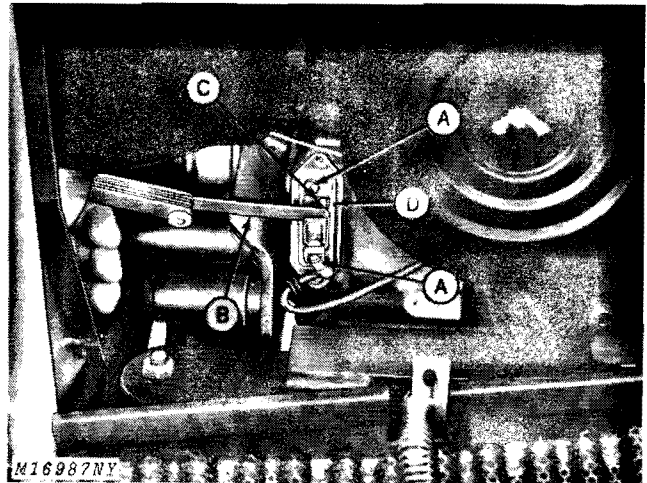

M16987NY

A—Retaining Screws C—Locking Screw
B—Feeler Gauge D—V-Slot

Fig. 6-Replacing and Adjusting Points

To replace points, remove retaining screws (A), Fig. 6. Be sure lock washers are in place when installing new points.

To adjust breaker points, rotate engine until "T" mark on flywheel lines up with indicator, Fig. 8. Use feeler gauge (B, Fig. 6) to measure gap for 0.020-inch (0.508 mm) clearance when points are fully open.

**Thank you very much
for your reading.**

Please Click Here

**Then Get More
Information.**